

QST

August, 1934
25 cents

devoted entirely to

amateur radio

In this Issue:

**New
Equipment
for the
Five-Meter
Band**

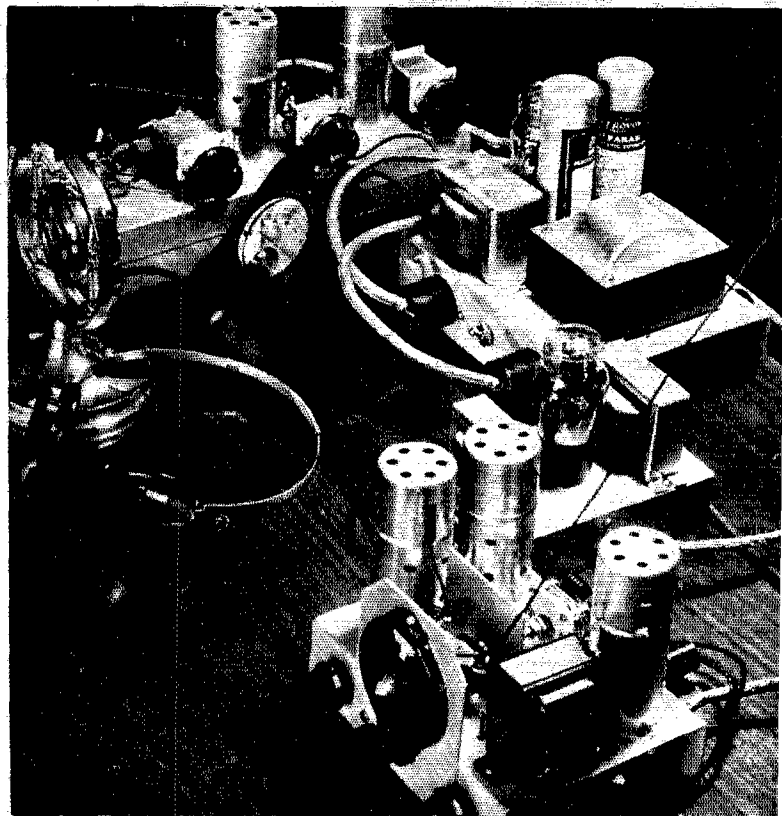

SPECIAL OFFER

A Year's Membership in QST for \$2.00

A Year's Subscription to QST for \$2.00

The Radio Amateur's Magazine

\$2.00
\$2.00

DURING

JULY

WED. AND

AUGUST

ONLY

THUR.

TUES.

2

Take advantage NOW, of this exceptional opportunity

QST has been the radio amateur's "bible" for almost 40 years. It is the world's leading authority on practical short-wave radio communication. QST is indispensable to radio amateurs and experimenters.

THE AMERICAN RADIO RELAY LEAGUE

1800 WASHINGTON
BOSTON

The Radio Amateur's Handbook is the most up-to-date and valuable book on short-wave radio. You will find out everything you need to know about the exciting world of short-wave radio. It is a must for every amateur radio operator.

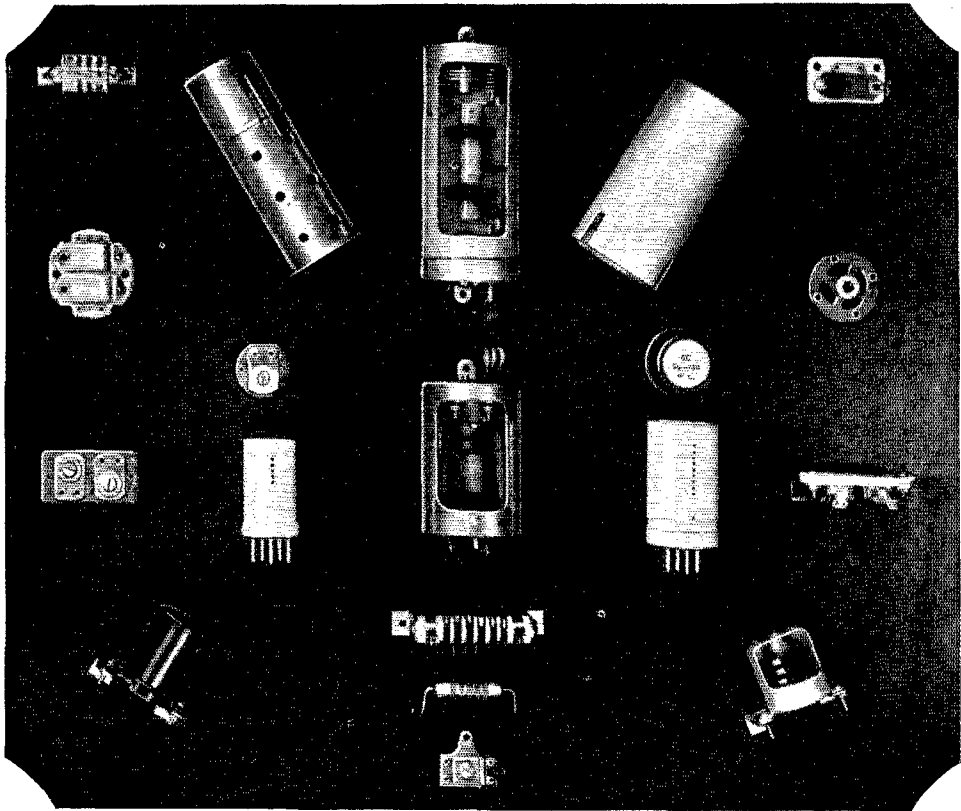

BOUGHT *for their* REPUTATION, SOLD *by their* PERFORMANCE!

YOU may buy Hammarlund Parts because you have heard they are good. But it is what they actually *do* which will sell you on their quality.

And that goes, too, for the COMET "PRO" 8-to-550 meter Superheterodyne. Custom-built by Hammarlund, from Hammarlund design, and using Hammarlund parts, the "PRO" has won world-wide acclaim for its consistent performance under the most trying conditions of amateur, professional and commercial use.

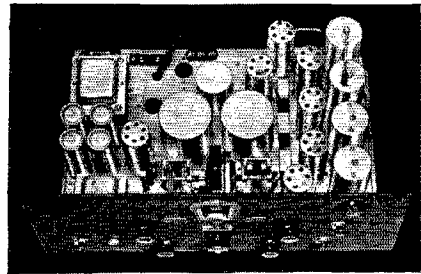

Mail Coupon for Details



For Better Radio
Hammarlund
PRECISION
PRODUCTS

HAMMARLUND MANUFACTURING CO.
424-438 W. 33rd St., New York

— Check here for General Catalog "34" of condensers and other precision radio equipment. — Check here for booklet describing the famous COMET "PRO" 8 to 550 meter Superheterodyne Receiver.

Name

Address

..... Q-8



THE RIBBON TYPE BATTERY

A NEW BURGESS PRODUCT

Believing that Radio Amateurs are interested in new developments, it is our plan to tell QST Readers about some of the ideas, methods and products evolved by Burgess engineers. ● For example—Mr. W. B. Schulte is showing here a new ribbon or flexible type of dry battery designed for, and especially useful in laboratory, experimental and testing work. It has these characteristics:—(1) Flexible; it may be rolled into a compact cylinder, folded into two or three layers, or laid out flat. It may be hung on the wall, against a receiver cabinet, or even wrapped about one's body for portable receiver use. (2) A potential of 114 volts with taps every 6 volts. (3) Weight, 6.2 lbs. (4) Cost approximately 2¢ a volt. ● To any radio amateur who may be interested in this, a detailed description will be forwarded upon request. The Ribbon Battery is a laboratory product, and offered for laboratory rather than general commercial use. Burgess Battery Company, Freeport, Illinois, U. S. A.

≡ BURGESS ≡

QST

Published monthly, as its official organ, by the American Radio Relay League, Inc., at West Hartford, Conn., U. S. A.; Official Organ of the International Amateur Radio Union

devoted entirely to

AMATEUR RADIO

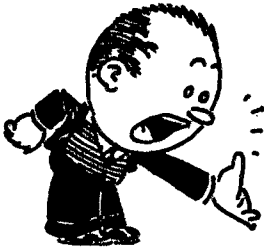

Editorials	9
WHFZ (W10XDA) Goes North	10
Midwest Division Convention	10
New Equipment for 56 Mc.	11
Pointers on Noise-Reducing Receiving Antenna Systems	11
<i>L. W. Hatry</i>	20
Behind the Scenes with Next Year's Model	20
<i>J. N. A. Hawkins, W6AAR</i>	25
A Medium-Powered 'Phone-C.W. Transmitter with Pentode Power Tubes. <i>C. A. Harvey, W1RF and R. M. Purinton, W1HTM</i>	27
Operating Notes	31
Rocky Mountain Division Convention	31
What the League Is Doing	32
A Four-Band Transportable 'Phone and C. W. Transmitter	36
<i>Frank M. Davis, W9FVM</i>	39
Amateur Radio at World's Fair	39
Reserved for YL's	40
Observations on Long-Delay Radio Echoes	42
<i>J. H. Dellinger</i>	43
Hamdom	43
Typical Technical Questions Answered	44
Saskatchewan Hamfest Well Attended	45
Experimenters' Section:	
STABILIZED 56-MC. TRANSMITTERS—AN INGENIOUS BUG—MAGNETS FOR THE VELOCITY MICROPHONE—PORTABLE FEEDERS—A "MARCONI-ZEPP"—PLUGS AND JACKS FOR AUTOMATIC FEEDER SWITCHING	46
Amateur Radio Stations	50
<i>W2GOX, W1DNF, W6HOG, VE3EU</i>	52
I. A. R. U. News	52
Communications Department	54
Correspondence Department	68
Standard Frequency Transmissions	78
New Protective Relays for Amateur Transmitters	80
Northwestern Division Convention	82
Dr. George W. Kirk, W8ARJ	82
Silent Keys	84
Central New York Convention	84
The Hudson Division Convention	86
Hamads	90
QST's Index of Advertisers	94

AUGUST
1934

VOLUME XVIII
NUMBER 8

Kenneth B. Warner (Secretary, A.R.R.L.), *Editor-in-Chief and Business Manager*; Ross A. Hull, *Associate Editor*; James J. Lamb, *Technical Editor*; George Grammer, *Assistant Technical Editor*; Clark C. Rodimon, *Managing Editor*; David H. Houghton, *Circulation Manager*; F. Cheyney Beekley, *Advertising Manager*; Ursula M. Chamberlain, *Assistant Advertising Manager*.

Editorial and Advertising Offices
38 La Salle Road, West Hartford, Conn.

Subscription rate in United States and Possessions and Canada, \$2.50 per year, postpaid; all other countries, \$3.00 per year, postpaid. Single copies, 25 cents. Foreign remittances should be by international postal or express money order or bank draft negotiable in the U. S. and for an equivalent amount in U. S. funds.

Entered as second-class matter May 29, 1919, at the post office at Hartford, Connecticut, under the Act of March 3, 1879. Acceptance for mailing at special rate of postage provided for in section 1103, Act of October 3, 1917, authorized September 9, 1922. Additional entry at Concord, N. H., authorized February 21, 1929, under the Act of February 28, 1925.

Copyright 1934 by the American Radio Relay League, Inc.
Title registered at United States Patent Office.

THE *Amateur's* BOOKSHELF

A balanced selection of good technical books, additional to the A.R.R.L. publications, should be on every amateur's bookshelf. We have arranged, for the convenience of our readers, to handle through the QST Book Department those works which we believe to be most useful. Make your selection from the following, add to it from time to time and acquire the habit of study for improvement. Prices quoted include postage. Please remit with order.

RADIO THEORY AND ENGINEERING

COMMUNICATION ENGINEERING, by *W. L. Everitt*. A general text for both first year and advanced courses. 567 pp., 335 illustrations. \$5.00

RADIO ENGINEERING, by *F. E. Terman*. A comprehensive treatment covering all phases of radio communication. A good all around book for students and engineers. 688 pp., 418 illustrations. \$5.00

MANUAL OF RADIO TELEGRAPHY AND TELEPHONY, by *Commander (now Admiral) S. S. Robinson, U. S. N.* Published by the Naval Institute. Covers both the theoretical and practical fields. 791 pp., 6¼ x 9. \$4.00

ELEMENTS OF RADIO COMMUNICATION, by *Prof. J. H. Morecroft*. This is the 2nd edition of this book by the author of the "Principles" listed elsewhere. It is about half the size of the larger work, and the subject is treated in more elementary fashion. Simple algebra is sufficient. An excellent book for the "first-year" student. 279 pp., 170 illustrations. \$3.00

PRINCIPLES OF RADIO COMMUNICATION, by *Prof. J. H. Morecroft*. An elaborate general textbook, and one of the recognized standards on theory for the engineering student. A working knowledge of mathematics is desirable for the reader who expects to get the greatest benefit from this work. 1001 pp., 5¼ x 9. \$7.50

PRINCIPLES OF RADIO, by *Keith Henney*. This book is chock-full of meat for the experimenter. The subjects treated range from the fundamentals of electricity to the modern concepts of modulation and detection. 477 pp., 306 illustrations. \$3.50

THEORY OF THERMIONIC VACUUM TUBES, by *E. L. Chaffee*. Based on Dr. Chaffee's research and study at Harvard University, this book offers much new material and many new presentations, especially in connection with regeneration. Recommended particularly for advanced study. 652 pp., 360 illustrations. \$6.00

RADIO EXPERIMENTS AND MEASUREMENTS

RADIO FREQUENCY ELECTRICAL MEASUREMENTS, by *H. A. Brown*. A thoroughly practical book for the experienced amateur, the experimenter or engineer who has knowledge of the elementary principles of radio communication and of alternating currents. \$4.00

HIGH-FREQUENCY MEASUREMENTS, by *August Hund*. A thorough, modern book, especially useful in advanced laboratory work. Includes a chapter on piezo-electric determinations. 491 pp., 373 illustrations. \$5.00

EXPERIMENTAL RADIO ENGINEERING, by *Prof. J. H. Morecroft*. An excellent laboratory text directed specifically to

emphasizing the principles involved in the operation of radio apparatus and intended as a companion to the same author's "Principles." Following an introductory chapter on instruments and accessories, 51 choice experiments are outlined. 345 pp., 250 illustrations. \$3.50

EXPERIMENTAL RADIO, by *Prof. R. R. Ramsey*. Revised Edition. A splendid book for the experimenter. This is a laboratory manual, describing 128 excellent experiments designed to bring out the principles of radio theory, instruments and measurements. 150 illustrations, 229 pp., 5¼ x 7. \$2.75

COMMERCIAL EQUIPMENT AND OPERATING

RADIO THEORY AND OPERATING, by *Mary Texanna Loomis*. Although giving a moderate amount of theory, it is essentially a practical handbook for commercial and broadcast operators, and as such ranks among the foremost publications of this sort. Used as a textbook by many radio schools. A good book for any amateur. 1000 pp., 800 illustrations. \$4.25

THE RADIO MANUAL, by *George E. Sterling*. Another excellent practical handbook, especially valuable to the commercial and broadcast operator, and covering the principles, methods and apparatus of all phases of radio activity. Over 900 pp. \$6.00

RADIO TELEGRAPHY AND TELEPHONY, by *Duncan and Drew*. Still another work along the lines of a general practical handbook. In size it is approximately the same as the two listed just previously, and the subject matter generally follows along the same lines. A good book in this class. 950 pp., 468 illustrations. \$7.50

HOW TO PASS U. S. GOVERNMENT RADIO LICENSE EXAMINATIONS, by *Duncan and Drew*. Intended as a companion volume to "Radio Telegraphy and Telephony" by the same authors, as a guide to the applicant for commercial

licenses. It is not a text in itself. The chapter arrangement follows that of the sections of the commercial theoretical examination, each being made up of typical examination questions and their answers. 169 pp., 92 illustrations. \$2.00

RADIO TRAFFIC MANUAL AND OPERATING REGULATIONS, by *Duncan and Drew*. A book for students, amateurs or radio operators who contemplate entering the commercial field; it will enable you to learn quickly and easily all the government and commercial traffic rules and operating regulations. 181 pp. \$2.00

PRACTICAL RADIO TELEGRAPHY, by *Wilson and Hornung*. Written particularly for the student training for a commercial license, and covering theory and apparatus. A practical handbook. 380 pp., 223 illustrations. \$3.00

RADIO OPERATING QUESTIONS AND ANSWERS, by *Wilson and Hornung*. A companion volume to "Practical Radio Telegraphy" by the same authors. The 1934 Revised Edition is very complete, covering Commercial and Broadcasting, Amateur, Aeronautical and Police Radio, Beacons, Airways, Meteorology, and Teletype Operating. 389 pp., 5¼ x 8. \$2.50

MISCELLANEOUS

THE RADIO AMATEUR CALL BOOK. Lists all U. S. and foreign amateur radio stations, s.w. commercials and broadcasters. \$1.10

BELOW TEN METERS, by *James Millen and R. S. Kruse*. Ultra-high-frequency oscillators, radiating systems, receivers, theories, measurements, television reception, etc. Abundant photographs and diagrams. 64 pp. \$5.00

ELECTRICITY, WHAT IT IS AND HOW IT ACTS, by *A. W. Kramer*. A modern treatment with the electron as its basis. It deals only with accepted theories, presenting them simply and straightforwardly so that those not mathematically minded can understand them. Two volumes, 592 pp., 242 illustrations. \$4.00

RADIO DATA CHARTS, by *R. T. Beatty*. A series of graphic charts for solving, without the use of mathematics, most of the problems involved in receiver design. 82 pp., 8¼ x 11. \$1.50

SERVICING RECEIVERS BY MEANS OF RESISTANCE MEASUREMENTS, by *J. F. Rider*. 203 pp., 94 illustrations. An excellent book for the service man and amateur constructor. \$1.00

WHO'S WHO IN AMATEUR RADIO. Gives photos, personal and station data on over 3000 amateurs. Also includes a comprehensive list of radio clubs, s. w. commercials, etc. 172 pp., 140 photos. \$1.00

AMERICAN RADIO RELAY LEAGUE, INC.
WEST HARTFORD, CONNECTICUT

Section Communications Managers of the A.R.R.L. Communications Department

All appointments in the League's field organization are made by the proper S.C.M., elected by members in each Section listed. Mail your S.C.M. (on the 16th of each month) a postal covering your radio activities for the previous 30 days. Tell him your DX, plans for experimenting, results in 'phone and traffic. He is interested, whether you are an A.R.R.L. member or get your QST at the newsstands; he wants a report from every active ham. If interested and qualified for O.R.S., O.P.S. or other appointments he can tell you about them, too.

Eastern Pennsylvania	W3GS	ATLANTIC DIVISION Jack Wagenseller	24 South Fairview Ave.	Highland Park, Upper Darby
Maryland-Delaware-District of Columbia	W3BAK	Edgar L. Hudson		Laurel, Delaware
Southern New Jersey	W3QL	Gedney Rigor	412 2nd Ave.	Haddon Heights
Western New York	W8DSP	Don Farrell	213 Hickok Ave.	Syracuse
Western Pennsylvania	W8CUG	C. H. Grossarth	R. F. D. 3, Eicher Rd.	Emsworth, Bellevue, Pa.
Illinois	W9WR	CENTRAL DIVISION Fred J. Hinds	6618 West 34th St.	Berwyn
Indiana	W9TE	Arthur L. Braun	911 Reisner St.	Indianapolis
Kentucky	W9OX	Carl L. Pfumm	P. O. Box 359	Louisville
Michigan	W8DYH	Kenneth F. Conroy	7538 E. Robinwood Ave.	Detroit
Ohio	W8BAH	Harry A. Tummonds	2073 West 85th St.	Cleveland
Wisconsin*	W9LPK	Carl F. Thoms	3802 W. Villard Ave.	Milwaukee
North Dakota	W9JVP	DAKOTA DIVISION Fred J. Wells	1022 11th St., S.	Fargo
South Dakota	W9PFI	Mike G. Strahon	601 S. Grange Ave.	Sionx Falls
Northern Minnesota	W9JIE	Robert C. Harshberger	1200 Fauquier St.	St. Paul
Southern Minnesota	W9DEI	Francis C. Kramer	W. Bluff St.	St. Charles
Arkansas	W5ABI	DELTA DIVISION H. E. Velte	2918 West 15th St.	Little Rock
Louisiana	W5DWW	W. J. Wilkinson, Jr.	1624 Allen Ave.	Shreveport
Mississippi*	W5VJ	W. P. Allen	P. O. Box 66	Jackson
Tennessee	W4AFM	F. F. Purdy	P. O. Box 173	Kingsport
Eastern New York	W2LU	HUDSON DIVISION Robert E. Haight	1080 Herdenger Ave.	Schenectady
N. Y. C. & Long Island	W2AZV	E. L. Baunach	7823 10th Ave.	Brooklyn
Northern New Jersey	W2EKM	John Rideg, Jr.	20 Buena Vista Rd.	Cedar Grove
Iowa	W9LEZ	MIDWEST DIVISION Phil D. Boardman	325 Kirkwood Blvd.	Davenport
Kansas	W9FLG	O. J. Spetter	305 Western Ave.	Topeka
Missouri	W9EYG-JPT	C. R. Cannady	300 Sixth St.	Monett
Nebraska	W9FAM	Samuel C. Wallace	Green St.	Clarke
Connecticut	W1CTI	NEW ENGLAND DIVISION Frederick Ells, Jr.	19 Merrill Rd.	Norwalk
Maine	W1CDX	John W. Singleton	10 High Street	Wilton
Eastern Massachusetts	W1ASI	Joseph A. Mullen	16 Mercier Ave.	Ashmont
Western Massachusetts	W1BVR	Percy Noble	37 Broad St.	Westfield
New Hampshire	W1AFK	Basil Cutting		Pembroke
Rhode Island	W1QR	Albert J. King	66 Lisbon St.	Providence
Vermont	W1ATF	Harry Page	R. 1	Hinesburg
Alaska	K7PQ	NORTHWESTERN DIVISION Richard J. Fox	Box 301	Ketchikan
Idaho	W7AYP	Don D. Oberbillig	P. O. Box 1271	Boise
Montana	W7AAT	O. W. Viers		Red Lodge
Oregon	W7ABZ	Raymond W. Cummins	4835 N. Amherst St.	Portland
Washington	W7AYO	Stanley J. Belliveau	Route 7, Box 387	Yakima
Hawaii	K6EWQ	PACIFIC DIVISION Atlas O. Adams	21st Infantry Brigade	Schofield Barracks
Nevada	W6EAD	Keaton L. Ramsay	1151 Buena Vista Ave.	Reno
Los Angeles	W6BPU	Howell C. Brown	120 N. El Molino Ave.	Pasadena
Santa Clara Valley*	W6DBB	Barton A. Wood	R. 1, Box 722	Campbell
East Bay	W6ZX	P. W. Dann	1821 Chestnut St.	Berkeley
San Francisco	W6CAL	Bryon Goodman	144 Alton Ave.	San Francisco
Sacramento Valley	W6DVE	Geo. L. Woodington	716 Redwood Ave.	North Sacramento
Arizona	W6BIF-W6QC	Ernest Mendoza	1434 East Madison St.	Phoenix
Philippines	KA1XA	Newton E. Thompson	P. O. Box 593	Manila, P. I.
San Diego	W6EOP	Harry A. Ambler	4101 Hamilton St.	San Diego
San Joaquin Valley	W6DZN	G. H. Lavender	Route 6, Box 425	Stockton
North Carolina	W4AVT	ROANOKE DIVISION G. H. Wright, Jr.	2817 Montrose Ave.	Wendell
Virginia	W3AAJ	R. N. Eubank	100 20th St.	Richmond
West Virginia	W8HD	C. S. Hoffmann, Jr.		Warwood, Wheeling
Colorado	W9BTO	ROCKY MOUNTAIN DIVISION T. R. Becker	1176 Gaylord St.	Denver
Utah-Wyoming	W6GQC-IDM	Arty W. Clark	260 So. 9th West	Salt Lake City, Utah
Alabama	W4KP	SOUTHEASTERN DIVISION L. D. Elwell	1066 Waverly St.	Tarrant
Eastern Florida	W4NN	Ray Atkinson	4524 College St.	Jacksonville
Western Florida	W4MS	Edward J. Collins	1517 East Brainard St.	Pensacola
Georgia-So. Carolina-Cuba- Isle-of-Pines-Porto Rico- Virgin Islands	W4UT	George A. Love	50 Muscooge Ave.	Atlanta
Northern Texas	W5AUL	WEST GULF DIVISION Glen E. Talbutt	1133 Amarillo St.	Abilene
Oklahoma	W5CEZ	Carter L. Simpson	2010 So. 4th St.	Ponca City
Southern Texas	W5BHO	David H. Calk	6726 Ave. Q	Houston
New Mexico	W5DUI	Dan W. De Lay	407 South Girard St.	Albuquerque
Maritime	VE1DQ	MARITIME DIVISION A. M. Crowell	69 Dublin St.	Halifax, N. S.
Ontario	VE3GT	ONTARIO DIVISION S. B. Trainer, Jr.	4 Shorncliffe Ave.	Toronto
Quebec	VE2GA	QUEBEC DIVISION J. A. Robertson	245 Edison Ave.	St. Lambert, P. Q.
Alberta	VE4GD	VANALTA DIVISION J. Smalley, Jr.	611 1st Ave., N. W.	Calgary
British Columbia	VE5AC	R. K. Town	1754 Graveley St.	Vancouver
Manitoba	VE4GC	PRAIRIE DIVISION Reg. Strong	711 Ashburn St.	Winnipeg
Saskatchewan	VE4EL	Wilfred Skaike	2040 McTavish St.	Regina

* Officials appointed to act until the membership of the Section choose permanent S.C.M.'s by nomination and election.

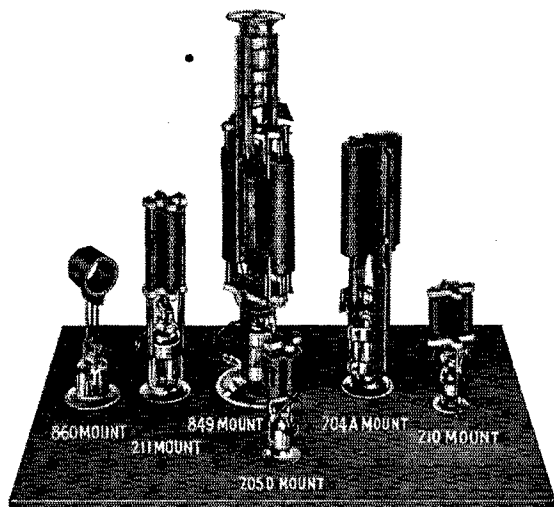

GRAPHITE ANODES

HAVE SET NEW
STANDARDS
IN TUBE
DESIGN

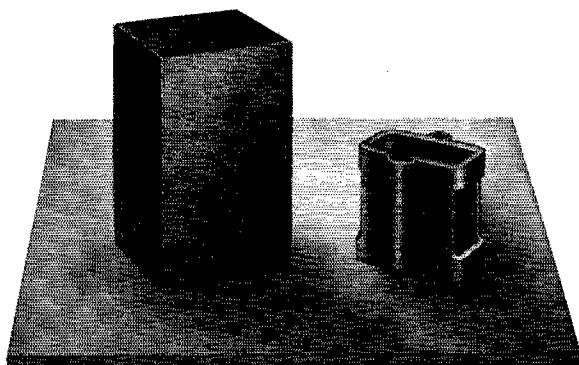
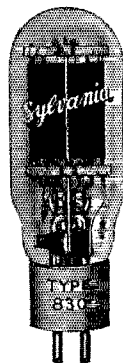
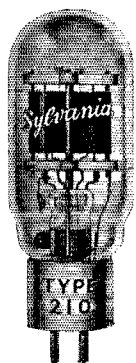

HYGRADE SYLVANIA CORPORATION

ELECTRONICS DEPARTMENT
AMATEUR RADIO DIVISION
CLIFTON, N. J.



FACTORIES:

EMPORIUM, PA.

ST. MARYS, PA.

SALEM, MASS.

CLIFTON, N. J.

..... *Sylvania*
REG. U.S. PAT. OFF.

FIRST TO MANUFACTURE
SUCCESSFULLY
A COMPLETE LINE OF
GRAPHITE ANODE
TRANSMITTING TUBES!

The specialized transmitting tube engineers of Hygrade Sylvania Corporation's Electronics Department originated and developed the only complete line of standard air cooled transmitting tubes embodying GRAPHITE ANODES.

Sylvania has started a procession. Broadcasters and amateurs are clamoring vociferously for GRAPHITE ANODE tubes for use in their transmitters. All are hungry for this truly modern tube design. Fall in line with the many followers of Sylvania and enjoy the long service life and lower operating costs that Sylvania GRAPHITE ANODES can deliver.

Sylvania sustained leadership in GRAPHITE ANODE tubes is unchallengeable proof of an extraordinary engineering personnel.

That Sylvania can give you better transmitting tubes, is the safest kind of a bet.

HYGRADE SYLVANIA CORPORATION

ELECTRONICS DEPARTMENT
AMATEUR RADIO DIVISION
CLIFTON, N. J.



FACTORIES:

SALEM, MASS.

ST. MARYS, PA.

EMPORIUM, PA.

CLIFTON, N. J.

Say You Saw It in QST — It Identifies You and Helps QST

The American Radio Relay League



• **T**HE AMERICAN RADIO RELAY LEAGUE, INC., is a non-commercial association of radio amateurs, bonded for the promotion of interest in amateur radio communication and experimentation, for the relaying of messages by radio, for the advancement of the radio art and of the public welfare, for the representation of the radio amateur in legislative matters, and for the maintenance of fraternalism and a high standard of conduct.

It is an incorporated association without capital stock, chartered under the laws of Connecticut. Its affairs are governed by a Board of Directors, elected every two years by the general membership. The officers are elected or appointed by the Directors. The League is non-commercial and no one commercially engaged in the manufacture, sale or rental of radio apparatus is eligible to membership on its board.

"Of, by and for the amateur," it numbers within its ranks practically every worth-while amateur in the world and has a history of glorious achievement as the standard-bearer in amateur affairs.

Inquiries regarding membership are solicited. A bona fide interest in amateur radio is the only essential qualification; ownership of a transmitting station and knowledge of the code are not prerequisite. Correspondence should be addressed to the Secretary.

DIRECTORS

<i>President</i>	
HIRAM PERCY MAXIMW1AW Box 216, Hartford, Conn.
<i>Vice-President</i>	
CHARLES H. STEWARTW3ZS St. David's, Pa.
<i>Canadian General Manager</i>	
ALEX. REIDVE2BE 169 Logan Ave., St. Lambert, P. Q.
<i>Atlantic Division</i>	
EUGENE C. WOODRUFFW8CMP 234 W. Fairmount Ave., State College, Pa.
<i>Central Division</i>	
LOREN G. WINDOMW8GZ-W8ZG 1375 Franklin Ave., Columbus, Ohio
<i>Dakota Division</i>	
CARL L. JABSW9BVH 1822 James St., St. Paul, Minn.
<i>Delta Division</i>	
M. M. HILLW5EB P. O. Box 274, Natchitoches, La.
<i>Hudson Division</i>	
BERNARD J. FULDW2BEG 280 Broadway, New York City
<i>Midwest Division</i>	
H. W. KERRW9DZW-W9GP Little Sioux, Iowa
<i>New England Division</i>	
G. W. BAILEYW1KH 74 Webster Road, Weston, Mass.
<i>Northwestern Division</i>	
RALPH J. GIBBONSW7KV-W7BIX 3134 N. E. 25th Ave., Portland, Ore.
<i>Pacific Division</i>	
S. G. CULVERW6AN 2962 Russell St., Berkeley, Calif.
<i>Roanoke Division</i>	
H. L. CAVENESSW4DW State College Station, Raleigh, N. C.
<i>Rocky Mountain Division</i>	
RUSSELL J. ANDREWSW9AAB 1867 So. Lafayette St., Denver, Colo.
<i>Southeastern Division</i>	
J. C. HAGLER, JR.W4SS 2424 McDowell St., Augusta, Ga.
<i>West Gulf Division</i>	
FRANK M. CORLETTW5ZC 2515 Catherine St., Dallas, Tex.

OFFICERS

<i>President</i>HIRAM PERCY MAXIM, W1AW Hartford, Connecticut
<i>Vice-President</i>CHARLES H. STEWART, W3ZS St. David's, Pennsylvania
<i>Secretary</i>KENNETH B. WARNER, W1EH West Hartford, Connecticut
<i>Treasurer</i>ARTHUR A. HEBERT, W1ES West Hartford, Connecticut
<i>Communications Mgr.</i>F. EDWARD HANDY, W1BDI West Hartford, Connecticut
◆	
<i>General Counsel</i>PAUL M. SEGAL, W3EEA 1010 Shoreham Building, Washington, D. C.
◆	

Address all general correspondence to the executive headquarters at West Hartford, Connecticut

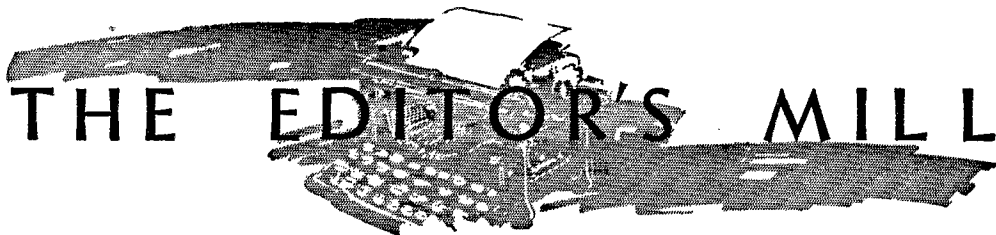

THE EDITOR'S MILL

THROUGH the efforts of A.R.R.L., amateur radio now has the privilege of engaging in general mobile operation on the frequencies from 56 to 60 megacycles and above 110 megacycles, and without the necessity for filing any special notifications before engaging in this work. Heretofore our only mobile authorization has been for use on aircraft but now we have the right to make ultra-high-frequency installations on automobiles, trailers, cruisers and canoes and use them while in motion; we may build pack sets and talk while climbing mountains (if our wind is good enough to spare breath for speech)—and anything else our fertile imagination conjures up.

What marvelous possibilities for sport and experiment are now opened to us! The mind leaps to many an intriguing opportunity. The portability and inexpensiveness of ultra-high-frequency apparatus make it possible for every amateur to have a set on his car and we suspect that every amateur with a car will want to do just this. The right to engage in automobile operation will teach us many interesting things about the performance of ultra-high frequencies, and as we roll along cross-country we can be in touch with the gang in every town and city. Give your fancy rein for a moment and imagine that you are driving, to Chicago, say, for the first time. Approaching an unfamiliar town, you pick up the mike and send out a CQ. Immediately a local amateur answers you and you have all the dope. He invites you to drop by and see him but you don't know how to get there. Describing your location to him, he tells you where to turn and brings you right up to his house, where he is standing on the curb to greet you! Or imagine that you have a rig in the rowboat. The YF can now tell you that it is time to stop fishing and come home for chow. That may not be so good, but every good receiver should have a cut-out switch in it anyway.

The details on the new regulations are elsewhere in this issue. Bear in mind that in such mobile operation you must have your original operator license with you and either the original or a photostat copy of your station license. Also note that, although it is not necessary to notify the radio inspector of such operation, it is necessary on every transmission to state the call area in which you are operating (the same as for portable operation) and to note in the log your approximate location.

In some localities we may come in conflict with local laws, so far as automobile operation is concerned, where communities have adopted regulations intended to prevent the improper interception of police radio reports. Amongst others, New Jersey, New York, Indiana, Illinois and Michigan and the cities of Cincinnati, Dayton, Kansas City, Los Angeles, Louisville and Syracuse have local laws the general intent of which is to prohibit the installation of short-wave receivers in automobiles without a permit from the proper authority, and similar ordinances have been proposed and possibly enacted in Miami, San Diego and Spokane. Some of the regulations apply only to receiving installations capable of receiving signals on the frequencies allocated for police use but others of them apply to any receiving installation, and the local authorities may be tempted to consider that they apply even to Federally-licensed two-way stations. The League has long been studying the progress of these regulations. The validity of the limitations imposed by them is regarded by competent legal authority as an open question and it is impossible at this time to establish any categorical standards for the general guidance of amateurs. The subject is still under study, even including the possibility of promoting national legislation to supersede these local ordinances in some uniform and satisfactory manner, and A.R.R.L. is doing its best to unsnarl the situation. Meanwhile amateurs in these localities should ascertain what local restrictions may be binding upon them, and they are requested to report on all state laws and city ordinances to A.R.R.L. headquarters, sending copy for study when possible, and reporting any difficulty in obtaining permits.

And now a note of warning: The amateur mobile privilege, like every other amateur right, is available only to amateurs and for *amateur purposes*. The opening of this new facility may attract non-amateurs into endeavoring to qualify as amateurs simply to be able to employ this privilege for utilitarian communication. Naturally the League opposes this, and it calls upon amateurs everywhere to discourage those who have no "heart interest" in amateur radio from attempting to qualify simply in the desire to make use of our privileges. Amateur radio is a hobby; its distinguishing characteristic is a personal and non-commercial interest in communicating. Our frequencies may be used only for

amateur work and mobile ultra-high-frequency communication may not be engaged in as an adjunct to any business enterprise nor for any strictly utilitarian purpose. The right is confined to those who have an *interest in the technique of communicating*. For example, amateurs have the right to employ mobile 56-mc. equipment on their boats but we do not want our band converted into a marine band for those who merely legally qualify as amateurs—there are plenty of marine frequencies available for them. Let us make it clear right from the start that this is strictly an amateur privilege.

K. B. W.

WHFZ (W10XDA) Goes North

THE Schooner *Morrissey*, under command of Captain Bob Bartlett, sailed for northern waters again on June 14th. Hundreds of amateurs will have fond recollections of 14-mc. 'phone and c.w. contacts with the *Morrissey* on her 1933 trip, at that time under Canadian registration and known to the gang familiarly as VOQH.

Robert B. Moe (Bob) of W2UN is again in full charge of radio communications from WHFZ. He completely rebuilt the equipment (from QST dope) and, in fact, was so busy with the installation that final information is being sent us from Newfoundland; we hope to present details in subsequent issues. This season two calls have been assigned, one regular ship license and one special experimental license.

Power supply is obtained from a rotary converter from the ship's batteries (120 v.d.c. to 115 v.a.c.). The tube line-up consists of 47 oscillator, 46 doubler, 841 r.f. amplifier and 203-A modu-

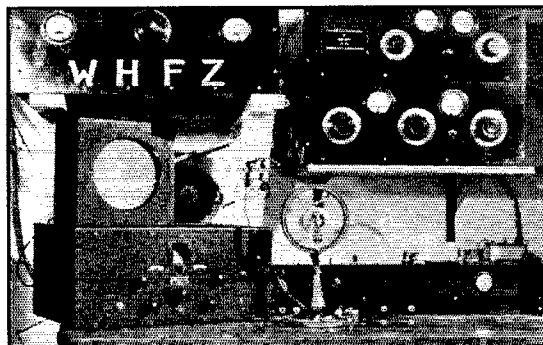

lated amplifier. Push-pull 45-driven and '10 Class-B modulator follow the 2-stage 37 speech amplifier. Test schedules with the Columbia Broadcasting System have been arranged, and some re-broadcasts may be attempted.

WHFZ is the regular ship call assigned for work in 17-, 24- and 36-meter bands. W10XDA is the call for 8655 kc., 12,862 kc. and 17,310 kc. Permission has also been granted for use of 6425, 23,100 and 27,100 kc., and these will be used as soon as the crystal blanks are finished up.

Bob Moe writes, "The League certainly made a wonderful success of our communication work

last year, and we are counting on it this year.

"The trip itinerary is as follows: Brooklyn, N. Y.; Brigus, Nfld. (Captain Bartlett's mother's home); Turnavik, Labrador; Cape York, Greenland, where we shall inspect the Peary monument built by Captain Bartlett in 1932; Grantland; Ellesmereland; Baffinland, Fury and Hecla Straits and, if possible, through the Straits, where passage by ship has been impossible heretofore. Then the return will be through Foxe Basin, Foxe Channel, Hudson Straits, down the Labrador coast and home again."

Midwest Division Convention

August 31st-September 1st—Lincoln, Nebr.

CONVENTIONS may come and go, but the Midwest Division Convention is always a leader and it is expected that this year's official divisional convention will outdo previous ones. The Cornhusker Amateur Radio Association is sponsoring the event, and they will have the support of both the University of Nebraska and the Wesleyan University, which insures some good talks. Convention headquarters for Friday, August 31st, will be in room 206, Mechanical Engineering Building, University of Nebraska, and those arriving Saturday, Sept. 1st, register at Wesleyan University. Information will also be available at the Y. M. C. A., where an attendant will be ready to assist.

Come prepared to be initiated into the R.O.W.H. There is a good possibility of seeing and hearing Lieut.-Comdr. Schnell, W9UZ, and Lieut. John L. Reinartz, W1QP, of Arctic fame. Harbert D. Kimberly, Convention Chairman, 1222 Nelson St., Lincoln, Nebr., will give you further information if you write him.

Strays

To W2AOE goes the distinction of pulling off the first 5-meter QRR. While out in his transceiver-equipped car late one foggy night, he ran out of gas—with the nearest filling station about a mile away, as might be expected. By good fortune W2DX happened to be on the air; a hurried call got him, and in a few minutes the precious fluid arrived along with DX in his chariot!

New Equipment for the 56-Mc. Station

Complete Details of a Practical Stabilized Transmitter and Non-Radiating Receiver

By Ross A. Hull* and George Grammer**

IF THERE is any one reason for the present extraordinary popularity of 56-mc. amateur communication it is, without doubt, the utter simplicity of the equipment required. When twenty or thirty dollars worth of equipment will allow one to exploit the facilities of the 56-mc. band, the temptation to do so is exceedingly great. Had *QST* not seen fit to design, describe and recommend 56-mc. equipment of the utmost simplicity during the last few years, the probability is that ultra-high-frequency working would have continued to interest only advanced amateurs and laboratory workers. It is evident, then, that we owe a great debt to the simple modulated-oscillator transmitter and the simple super-regenerative 56-mc. receiver. Without such apparatus, the enormous value of our 5-meter band might have remained unknown.

The picture to-day, however, is changing rapidly. So great has the popularity of the 56-mc. band become, and so dense its population in some centers, that the frequency-modulated transmitter and radiating receiver can no longer be considered ideal in all cases. The time has come when amateurs in congested areas must turn their attention to stabilized transmitters and non-radiating receivers. Details of such apparatus have been presented on several occasions in *QST* during the last few years but its complexity would seem to have scared off most amateurs and manufacturers of amateur equipment.

The apparatus to be described is by no means as simple as much of the early 56-mc. gear. It is, however, a great deal simpler in construction and adjustment and infinitely more effective than any of the other "stabilized" equipment which has come to our notice.

THE TRANSMITTER

Many amateurs have the erroneous opinion that all one needs to get freedom from frequency

modulation in a 56-mc. transmitter is an oscillator tube feeding a modulated amplifier. Indeed, we know of one commercial manufacturer who was trapped by faith in the merits of an oscillator-amplifier into the expensive discovery that its frequency modulation could be substantially as severe as that of the modulated oscillator. The present transmitter gains its stability through the use of an electron-coupled oscillator-tripler or doubler as the driver tube and a well-shielded screen-grid tube (with very low grid-to-plate capacity) as the amplifier. The stability of the transmitter is of such a high order that its voice signals are still intelligible even when received with an oscillating autodyne receiver.

The complete transmitting outfit actually consists of three parts: the 56-mc. transmitter, the modulator, and the power supply. The last two pieces of apparatus will be described in the following sections; for the moment we will confine ourselves to the radio-frequency unit, photographs of which are given in Figs. 1, 3 and 4. The circuit diagram appears in Fig. 2.

Two Type 58 tubes are used in the transmitter,

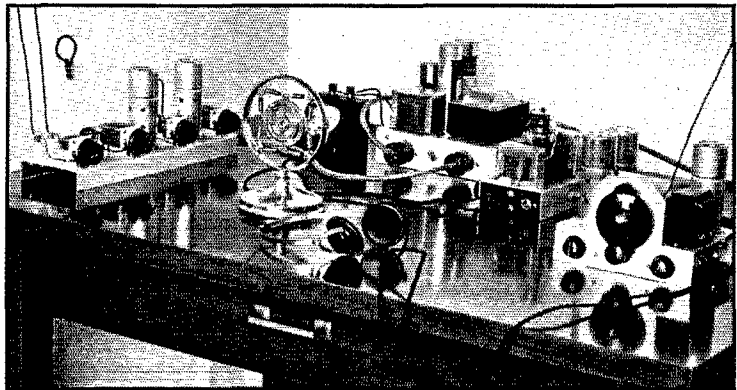

ILLUSTRATING ONE POSSIBLE SET-UP FOR THE NEW 56-MC. EQUIPMENT OPERATED AS A FIXED GROUND STATION

one as the electron-coupled oscillator and the second as the 56-mc. amplifier. The latter tube is modulated.

A front view of the transmitter is given in Fig. 1. The physical layout, it will be observed, almost exactly follows the circuit diagram. The metal chassis is made of aluminum and measures 13 by 4 inches, with $\frac{3}{4}$ -inch vertical sides.

* Associate Editor, *QST*.

** Assistant Technical Editor, *QST*.

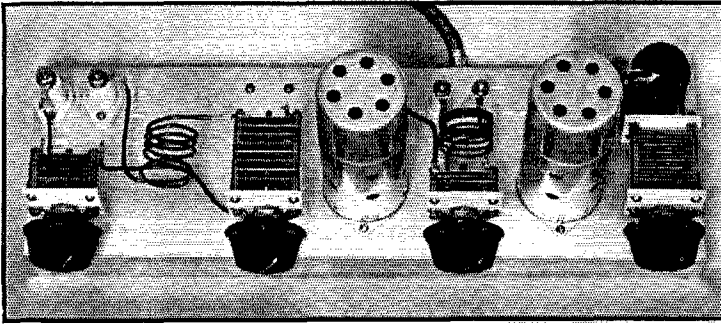

FIG. 1—A SIMPLIFIED HIGH-STABILITY 56-MC. TRANSMITTER

Type 58 receiving tubes show their splendid capabilities as transmitters in this rig. An unusually high order of stability under modulation is attained by the circuit design and layout.

The aluminum should be scratched rather deeply on the bending lines, on both sides of the sheet. It is then easy to bend over the sides along the scratch marks. After the socket holes have been cut out (a circle cutter is helpful for this job) the aluminum can be given a pleasing satin finish by immersing it in a lye solution (one can of lye to about a gallon of water) for a short time and then washing it in water.

The tuning condensers are Cardwell Trim-Airs, mounted on brackets supplied for the purpose. The oscillator tuning condenser C_4 is provided with mounting brackets at both ends so that this condenser will be quite solidly mounted. The double mounting helps to prevent frequency changes arising as the result of vibration. For the same reason the oscillator coil L_5 , which is just behind C_4 , is wound on a form instead of "on air" as are the other coils.

The oscillator plate-coupling coil L_4 is mounted on two feed-through stand-off insulators at the rear edge of the chassis behind C_3 . This coil is placed so that its axis coincides with that of L_3 , and is about $\frac{1}{4}$ -inch away from it. Its connections run down through the insulators to the under side of the chassis.

The rear view of the transmitter, Fig. 3, will be helpful should there be any doubt about the way in which the parts on top of the chassis are placed and wired.

By-pass condensers, resistors and r.f. chokes are placed

underneath the chassis, as shown in the bottom view, Fig. 4. In this photograph the right-hand tube socket is for the oscillator tube. Both sockets have their filament terminals lowermost. A connection from the oscillator-socket cathode prong runs through a hole in the chassis to the tap on L_5 indicated in Fig. 2. The suppressor and screen-grid prongs on this socket are connected together. Condenser C_{10} , just above the oscillator socket in Fig. 4, has one terminal connected to the screen-grid prong and the other grounded to a lug under the nut holding the upper socket screw in place. Resistor R_4 is to the right of the oscillator socket and R_3 to the left. The lower terminal of R_3 is soldered to a piece of bus-bar which in turn is fastened to a midget stand-off insulator acting as the positive plate-supply terminal for the

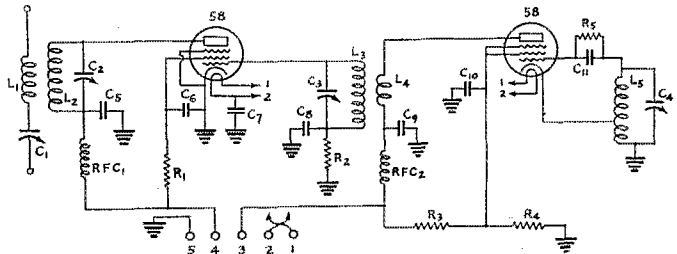

FIG. 2—CIRCUIT DIAGRAM OF THE OSCILLATOR-AMPLIFIER TRANSMITTER

Ground symbols indicate connections to the metal chassis.

- C_1 —50- μ fd. midget variable condenser (Cardwell Trim-Air Type RT-50).
- C_2 —30- μ fd. midget variable condenser (Cardwell Trim-Air Type XT-30).
- C_3 —25- μ fd. midget variable condenser (Cardwell Trim-Air Type RT-25).
- C_4 —140- μ fd. midget variable condenser (Cardwell Trim-Air Type RT-140).
- C_5 to C_{10} incl.—250- μ fd. midget mica condensers (Aerovox Type 1467).
- C_{11} —100- μ fd. mica condenser (Dubilier Type 3 with lugs).
- R_1 —50,000-ohm 1-watt resistor (I.R.C.).
- R_2 —25,000-ohm 1-watt resistor (I.R.C.).
- R_3 —50,000-ohm 20-watt resistor (Ohmite).
- R_4 —50,000-ohm 2-watt resistor (I.R.C.).
- R_5 —25,000-ohm 1-watt resistor (I.R.C.).
- RFC₁, RFC₂—Sectional-wound short-wave chokes (National Type 100).
- L_1 —2 turns No. 12 enamelled wire, coil diameter $\frac{1}{8}$ inch
- L_2 —4 turns No. 12 enamelled wire, coil diameter $\frac{1}{8}$ inch, length $\frac{1}{8}$ inch.
- L_3 —3½ turns No. 12 enamelled wire, coil diameter $\frac{1}{8}$ inch, length $\frac{1}{2}$ inch.
- L_4 —3 turns No. 12 enamelled wire, coil diameter $\frac{1}{8}$ inch, length $\frac{1}{2}$ inch.
- L_5 —5½ turns No. 12 enamelled wire, on 1-inch diameter (National) coil form, length $\frac{1}{8}$ inch; tapped 1½ turns from ground end.

The following additional components will be required:

- 2 6-prong Steatite tube sockets (National).
- 2 tube shields (Hammarlund Type TS-50).
- 2 feed-through stand-off insulators (Birnbach Type 458).
- 2 Small porcelain stand-off insulators (Birnbach Type 866).
- 2 midget porcelain stand-off insulators
- 4 feet of 5-wire shielded cable.
- 5 mounting brackets for Trimm-Air condensers (Cardwell).
- 1 5-prong plug or old tube base.

oscillator. The oscillator plate r.f. choke RFC_2 also is soldered to this insulator, its other terminal goes to the left-hand feed-through insulator (just above where the cable comes through the chassis). The other feed-through insulator is connected to the plate prong on the oscillator socket.

Between R_3 and the amplifier tube socket is R_2 , the amplifier grid leak. The grid by-pass condenser C_8 is just above it, one terminal being connected to the resistor and the other to a ground lug. The other two condensers at the top of the photograph are the screen and plate by-pass condensers, C_6 and C_5 . One connects to the screen prong on the socket and the other to one end of the amplifier plate choke RFC_1 , which is at the left. Beside the choke is the screen dropping resistor R_1 . Both RFC_1 and R_1 are soldered to a lug on the left-hand midget porcelain insulator, and also to one of the wires in the 5-wire cable (No. 4). The filament by-pass condenser C_7 connects between one filament prong on the amplifier tube socket and ground. In this stage the suppressor grid is connected directly to ground, not to the screen grid.

As in the remaining apparatus the shield on the cable is connected to the chassis. The terminals at the other end of the cable are soldered in the pins of a 5-prong tube base for connection to a socket on the power supply.

THE MODULATOR

The tube used in the modulator unit is a 2A5 pentode. This tube is capable of delivering the requisite audio power and has high enough

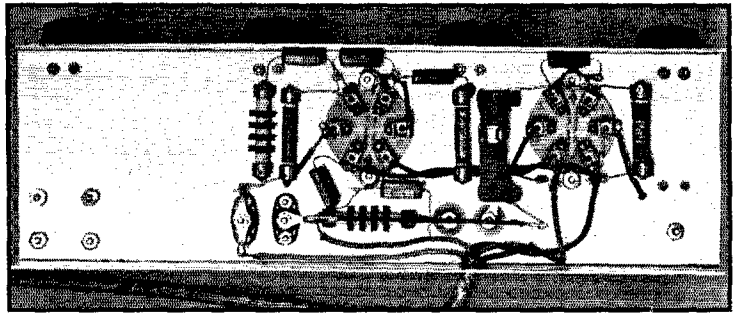

FIG. 4—A SUB-BASE VIEW OF THE OSCILLATOR-AMPLIFIER TRANSMITTER

By-pass condensers, resistors and chokes are located near the tube sockets with which they are associated in the circuit diagram

power sensitivity to permit operating its grid circuit directly from a single-button microphone without the necessity for an intermediate amplifier. It is operated as a Class-A modulator in order to avoid the power supply complications which would result from the use of Class-B if power supply voltage fluctuations were to be avoided.

The general construction of the modulator is similar to that of the other units in the station. The aluminum chassis, measuring 6 by 3½ inches, with 1½-inch side pieces, is bent in the same way as the bases for the receiver and transmitter. The microphone and output transformers, T_1 and T_2 , are mounted on the top, T_1 being the nearer one in the general view, Fig. 5. Fig. 6 is the circuit diagram of the modulator, while Fig. 7 shows the apparatus mounted underneath the chassis.

The small piece of bakelite fitted in one end of the chassis is used to hold the two binding posts to which the microphone battery is connected, the tip jacks into which the microphone cord is plugged, and the microphone on-off switch. This panel is fastened to the chassis by small metal angles, visible in the bottom-view photograph. Care should be taken to see that C_1 is properly connected: the negative terminal should go to ground and the positive to the cathode prong on the tube socket.

The output transformer T_2 is one designed for coupling out of a different type of audio stage than this one. Its characteristics, however, are well adapted to the work in hand if only one side of the primary is used. Be sure, therefore, to connect the positive plate supply terminal (No. 3) to the center tap of the primary winding. One of the other primary terminals should be connected to the plate

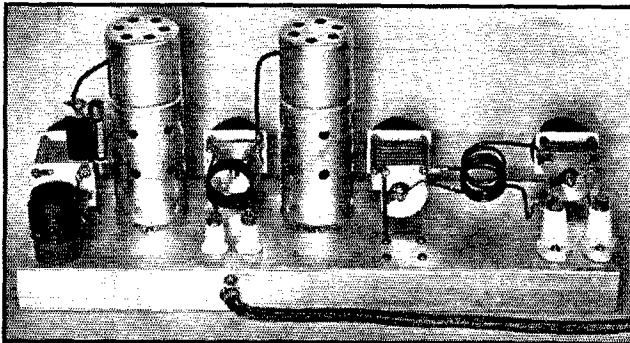

FIG. 3—THE REAR VIEW OF THE TRANSMITTER EMPHASIZES THE SIMPLICITY OF ITS CONSTRUCTION

The various parts are identified in the text.

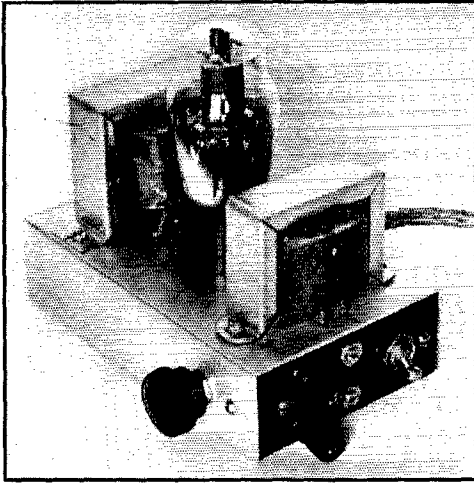

FIG. 5—THE MODULATOR FOR THE TRANSMITTER EMPLOYS A SINGLE 2A5 PENTODE

prong on the tube socket, while the remaining one should be left idle. One side of the secondary of T_2 should be connected to terminal No. 3, while the other side goes to wire No. 4 in the cable. The other end of the cable terminates in a 5-prong tube base similar to the one used on the transmitter cable. Through connections made in the power-supply unit, the secondary of T_2 is put in series with the plate supply lead to the amplifier tube in the r.f. unit, thereby introducing the modulation into the transmitter.

THE POWER SUPPLY

The third unit of the 56-mc. station is the power supply, shown pictorially in Figs. 8 and 10. It is capable of delivering all the filament and plate power required by the transmitter, modulator and receiver. The receiver needs 15 or 20 milliamperes at 200 volts for its plates; the transmitter and modulator together take approximately 70 to 80 milliamperes at 350 to 400 volts. Ordinary broadcast-receiver replacement power-supply parts are designed for just this type of load; such parts are used in the power supply shown. The circuit diagram with the list of components needed is given in Fig. 9. Other makes of apparatus can be substituted for those indicated, provided the electrical values are identical. Since the arrangement of parts is comparatively unimportant, physical differences in components will not matter, although it will be necessary to take them into account in planning the layout.

The front view shows clearly the parts mounted above the chassis. Two of the

connection-terminal sockets also are shown, as well as the toggle switch which cuts the transmitter and modulator plate supply on and off. This switch is provided so that the transmitter will not interfere during reception periods should its frequency be close to that of the station being received. A bakelite panel fitted in one end of the chassis holds two closed-circuit jacks to provide a means for measuring the plate currents taken by the transmitting tubes during operation.

The bottom view shows the plate-circuit jacks, the terminal sockets, and the two resistors constituting a voltage divider for the receiver. Be careful that none of the high-voltage connections touches the chassis, and make a thorough check of the wiring before connecting the unit to the power line. A 110-volt cord several feet in length, one end connected to the primary terminals of the power transformer and the other to a 110-volt plug, should be provided. Plugging into a 110-volt socket will therefore turn on the whole station. If desired, a switch may be inserted in the 110-volt cord to turn the set on and off, thus avoiding the necessity for inserting and removing the plug when the station is to be put into or taken out of operation.

If a voltmeter with a range of 0-500 or more is available, it would be well to check the output voltage after the power-supply unit is completed to make certain that the unit is functioning properly. The voltage should be measured between the chassis (negative) and the various high-

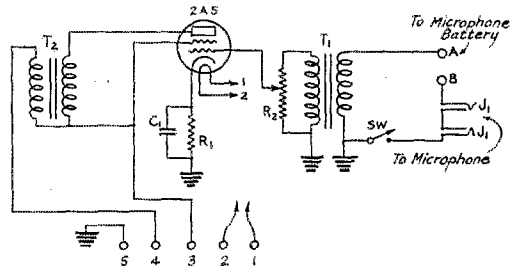

FIG. 6—MODULATOR CIRCUIT DIAGRAM

Connections to the metal chassis are indicated by ground symbols.

C_1 —10 μ fd. dry electrolytic condenser, 50-volt rating (Cornell-Dubilier Type ED-3100).

R_1 —600-ohm 10-watt resistor.

R_2 —500,000-ohm midget potentiometer (Centralab Type 72-106).

T_1 —Microphone transformer, for single-button microphone (Kenyon Type KSMG).

T_2 —Output transformer (Kenyon Type KR-79M).

The following additional components will be needed:

- 1 6-prong tube socket.
- 1 pair phone tip jacks J_1 .
- 1 toggle switch, single-pole single-throw.
- 2 binding posts, A, B.
- 4 feet of 5-wire shielded cable.
- 1 5-prong plug or old tube base.
- 1 single-button microphone (Shure Bros.).
- 6-volt dry-cell microphone battery.

voltage socket terminals. It will be quite high without the other units connected (450 to 500 volts on the modulator and transmitter sockets) and should drop to 350 or 400 volts when the station is running normally.

Power transformers of the type specified ordinarily are furnished with two 2.5-volt windings, one having high current-carrying capacity and the other low. Use the "high amp." winding.

TUNING THE TRANSMITTER

The transmitter just described has been designed in such a manner that the tuning process is reduced to a very simple routine. Indeed, the tuning is much more difficult to describe in words than it is to perform in actual practice. If the equipment has been built exactly according to the specifications, the only problems in tuning will be setting the transmitted frequency within the limits of the amateur band and obtaining the highest possible output power in the antenna.

Before beginning the tuning it is well to review the arrangement of the two jacks in the power-supply unit. J_1 is connected in the high-voltage supply lead to the oscillator tube. Hence a milliammeter plugged into J_1 will read the plate and screen-grid current of the oscillator tube as well as the few milliamperes taken by the voltage divider R_3-R_4 of Fig. 2. The jack J_2 is in the high-voltage lead to the modulator and hence will show the modulator plate current together with that taken by the screen and plate of the amplifier tube. When it is desirable to read only the load taken by the amplifier tube—as in the preliminary tuning procedure—the modulator tube is removed from its socket.

Having made a careful check of the wiring of the entire installation, the first step is to remove the modulator tube and plug the milliammeter

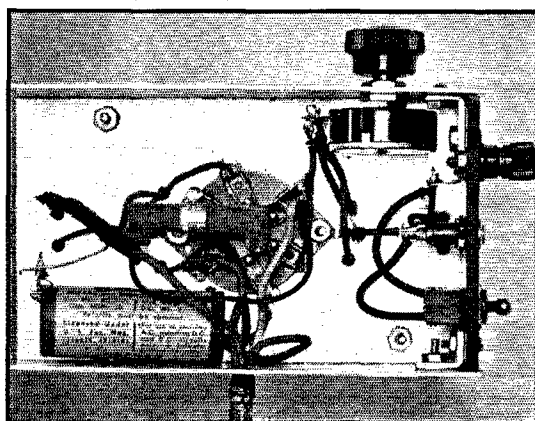

FIG. 7—UNDERNEATH THE MODULATOR CHASSIS
But few parts are required for this unit, which is essentially an audio power amplifier.

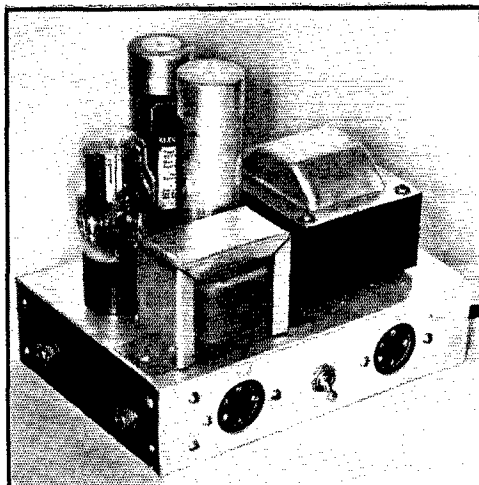

FIG. 8—THIS COMPACT POWER-SUPPLY UNIT FURNISHES ALL THE FILAMENT AND PLATE POWER REQUIRED BY THE TRANSMITTER, MODULATOR AND RECEIVER

Inexpensive components of the type intended for broadcast-receiver replacement purposes are used throughout.

into J_1 of the power-supply unit, setting the tuning condensers C_2 and C_3 at about one-third their maximum capacity setting. Now the power supply may be switched on and, when the tubes have warmed up, the oscillator load current noted. If this reading is of the order of 20 or 25 ma. it may be assumed that the tube is functioning properly. A further check may be made by touching the oscillator grid lead with a pencil, in which case the load current will show a slight deflection if the tube is oscillating. At this stage the milliammeter should be plugged into J_2 of the power-supply unit. The reading should be approximately 20 ma. Watching the meter carefully, the oscillator tuning knob should now be rotated slowly in the region around one-half the maximum capacity setting. A point will be reached at which the amplifier plate current makes a sharp rise of a few milliamperes. This will be the setting at which the frequency of the oscillator is one-third that of the tank circuit C_3-L_3 . Now a tuning lamp should be coupled closely to the coil L_2 , and condenser C_2 tuned until the lamp lights with the greatest brilliance. C_3 may then be retuned slightly to give the greatest output.

At this stage it will be well to listen on the receiver. The signal from the transmitter will cause a dead area on the receiver tuning dial and the center of this area will correspond roughly with the transmitter frequency. If this setting of the receiver can be compared with the setting at which signals of a known frequency have been received, it will

be possible to make a fairly accurate check of the frequency at which the transmitter is operating. If no signals are available with which to check the frequency it will be necessary to borrow or purchase a frequency meter with which to

itself which serves as a ground. Hence the other "antenna" terminal of the transmitter is connected by a short piece of wire to the metal chassis of the set itself. *M* in both diagrams may be a low-current flashlamp bulb or a thermo-coupled ammeter having a scale reading of 0.5 or 1 ampere. The actual antenna current obtained will usually be only of the order of 0.1 to 0.2 ampere, but either of these devices will serve to indicate when the antenna current is maximum.

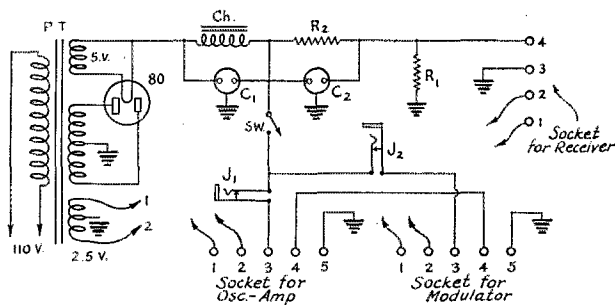

FIG. 9—THE POWER-SUPPLY CIRCUIT

Grounds indicate connections to the metal chassis.

PT—Power transformer; secondaries: 750 volts at 100 ma., center-tapped; 5 volts at 2 amp; 2.5 volts at 12 amp, center-tapped (Kenyon K-90 flush-type mounting)

CH—30-henry 75-ma. choke (Kenyon Type KC-350).

C₁, C₂—Double-section 500-volt electrolytic condensers 8-8 μfd. (Acrovex Type GG).

R₁—40,000-ohm 20-watt resistor (Ohmite).

R₂—10,000-ohm 10-watt resistor (Ohmite).

J₁, J₂—Closed-circuit jacks (Yaxley Type 702).

SW—Toggle switch, single-pole single-throw.

The following additional components will be required:

2 4-prong tube sockets (Eby).

2 5-prong tube sockets (Eby).

10 feet of lamp cord with plug.

measure the frequency. Should either of these tests show that the frequency is outside the amateur band running from 56 mc. to 60 mc., it will be necessary, of course, to retune the oscillator and the other two tuned circuits until the frequency is in the desired place.

It will be found that a second adjustment of the oscillator tuning condenser—almost at the minimum capacity setting—will allow the amplifier tube to operate in normal fashion. With this setting, the oscillator is operating at one-half the amplifier frequency instead of one-third. Though slightly greater output may be obtained in some cases under these conditions, the stability of the transmitter will not be quite as satisfactory.

THE TRANSMITTING ANTENNA

The essential requirement in a 56-mc. antenna is that it consist of a piece of wire suspended vertically as high as possible and well clear of any surrounding trees, wires or buildings. Also, the antenna must be cut exactly to one of the lengths shown in Fig. 11. In the diagram "A" of this figure is shown the simplest type of antenna—a vertical wire some odd multiple of 4 feet long; connected to one end of *L*₁. The antenna system is completed by the transmitter installation

itself which serves as a ground. Hence the other "antenna" terminal of the transmitter is connected by a short piece of wire to the metal chassis of the set itself. *M* in both diagrams may be a low-current flashlamp bulb or a thermo-coupled ammeter having a scale reading of 0.5 or 1 ampere. The actual antenna current obtained will usually be only of the order of 0.1 to 0.2 ampere, but either of these devices will serve to indicate when the antenna current is maximum.

TUNING THE ANTENNA

When the transmitter has been tuned in the manner described, we may connect the antenna system and tune it to the transmitted frequency. The first step is to remove the tuning lamp from its position near the coil *L*₂. Then *C*₂ is retuned until the amplifier load current is a minimum. Now the antenna tuning condenser is rotated slowly until the maximum indication is secured in the ammeter or flashlamp bulb in the antenna circuit. An alternative method is to leave the tuning lamp coupled to the amplifier plate coil and tune the antenna condenser until the tuning lamp becomes dimmest. Then the tuning lamp is removed and

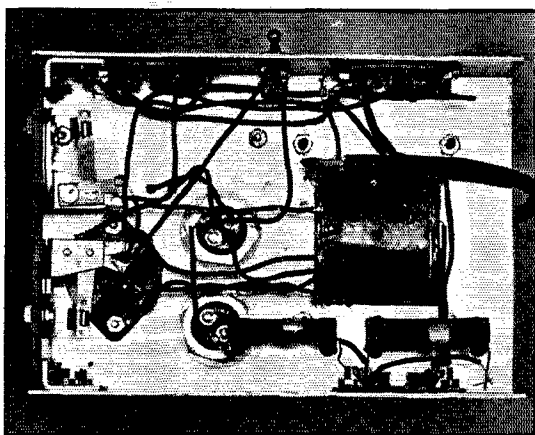

FIG. 10—ALL THE WIRING OF THE POWER-SUPPLY UNIT IS UNDERNEATH THE CHASSIS

This sub-base view shows the voltage-divider resistors, the connection sockets for the receiver, transmitter and modulator, and the metering jacks for measuring transmitter plate currents.

condenser C_2 retuned until the amplifier plate current is lowest.

BUILDING THE RECEIVER

Receivers used for 56-mc. work are still almost exclusively of the super-regenerative type. The super-regenerative detector not only is remarkably sensitive to weak signals but also possesses the property of discriminating between locally-generated damped oscillations, such as those set up by automobile ignition systems, and continuous-wave signals, amplifying the latter a great many more times than it does the noise. The one disadvantage of this type of set in its simple form is its ability to radiate a strong signal. For this reason the modern 56-mc. super-regenerative receiver should be provided with a radio-frequency amplifier. The r.f. stage brings other benefits as well: it increases the sensitivity of the receiver and, by acting as a buffer between the detector and antenna, improves the stability of the detector by eliminating antenna-resonance effects.

Fig. 12 shows a modern receiver of this type. Fig. 13 is the circuit diagram of the receiver. The r.f. amplifier tube is a Type 58, the detector a 56, and the audio amplifier also a 56. The receiver is designed for headphone reception, although the substitution of a power pentode for the 56 in the audio stage would make it suitable for operating a loud-speaker. The use

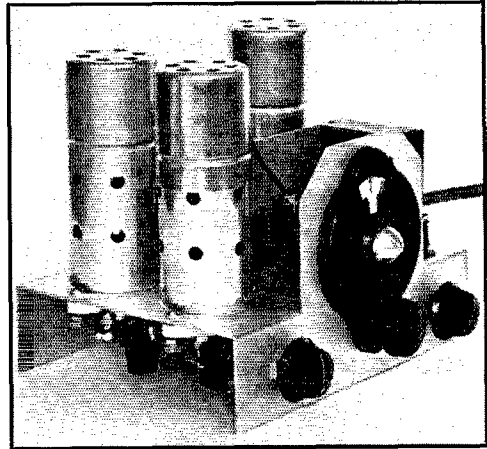

FIG. 12—A THREE-TUBE RECEIVER FOR THE 56-MC. BAND

A tuned radio-frequency amplifying stage is followed by a super-regenerative detector and an audio amplifier.

The chassis is most simply made by first cutting out a flat piece of aluminum measuring 8 by 7 inches, then drawing a line $1\frac{1}{2}$ inches in from each 7-inch side, leaving a center portion 5 by 7 inches.

The plan view shows the layout of parts on top of the chassis. The two tuning condensers, C_1 and C_2 , are centered on the chassis and are mounted with their shafts in line for ganging.

Both C_1 and C_2 are mounted by means of special brackets fitting the Cardwell condensers; the design of these brackets is such that the condensers are insulated from the chassis—a desirable feature in this case since the detector tuning condenser C_2 must not be grounded. This should be kept in mind if a different type of condenser is used.

Between the two tuning condensers is a vertical shield of sheet aluminum, its purpose being to help isolate the r.f. and detector stages and prevent the r.f. tube from oscillating.

The antenna coupling condenser C_3 is fastened to the stationary plates of C_1 . Ordinary trimmers will not do because their minimum capacity is too high. The Hammarlund Equalizer has a range of 3 to 35 $\mu\text{fd.}$, and as ordinarily used is set toward the low-capacity end, with the movable plate well separated from the stator. The extension of the stator plate is bent almost at a right angle so C_3 can be mounted on one of the screws holding the stator plates of C_1 and still be reached by a screwdriver from above the receiver for adjustment.

The r.f. coil, L_1 , is mounted vertically at the left of C_1 . No special mountings are provided; the upper end of the coil is simply soldered to the lug on the stator plates of C_1 and the lower end to a soldering lug fastened to the chassis by a short

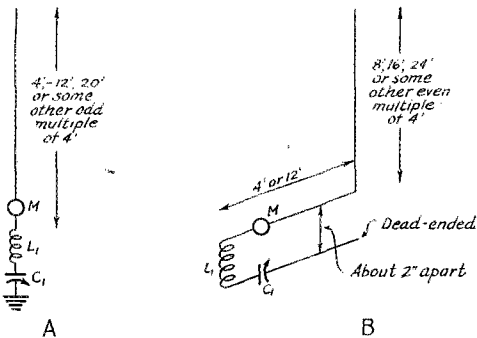

FIG. 11—TWO TYPES OF ANTENNA SYSTEMS SUITABLE FOR THE TRANSMITTER

These antennas may be erected either indoors or outdoors, preferably the latter. The performance of the station will be greatly dependent on the height of the antenna and the freedom from near-by wires, trees and buildings.

of headphones is usually preferable, however, when "duplex" operation is to be attempted.

Figs. 12, 14 and 15 show the details of construction quite clearly; a careful study of them should make the building of the receiver a fairly simple task. The metal chassis is a piece of $1/16$ -inch sheet aluminum bent in the shape of a broad, squat "U". The horizontal part measures 7 by 5 inches; the vertical sides are $1\frac{1}{2}$ inches high.

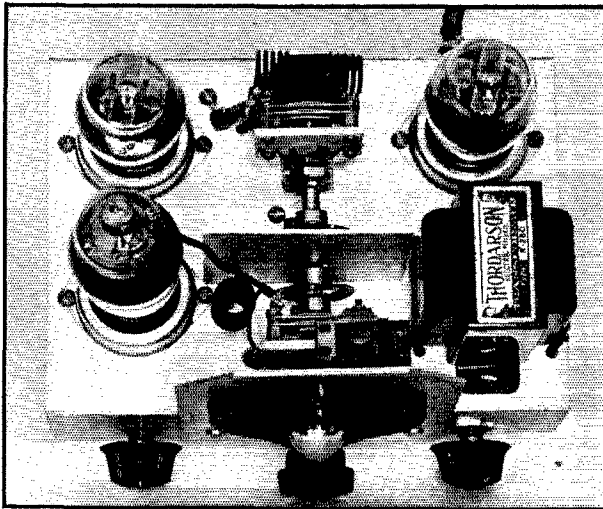

FIG. 14—THE 56-MC. RECEIVER IN PLAN

The r.f. amplifier tube is at the lower left, with the detector immediately above. The audio tube occupies the upper-right-hand corner. The knobs projecting from the front of the chassis at the left and right are for the regeneration-control and volume-control resistors, respectively.

machine screw. The rotor plate connection to C_1 is made to the same lug. The grid lead for the r.f. tube comes off the same stator-plate lug of C_1 to which the upper end of L_1 is soldered.

The detector coil is split into two parts, L_2 and L_3 , both wound the same way. Looking at Fig. 14, the left-hand end of the left-hand coil, L_2 , is soldered to the lug on the stator plates of C_2 . The outer end of L_3 , the right-hand coil, connects to the rotor-plate terminal. The inside ends of both coils are connected to opposite terminals of a midget 100- μ fd. mica condenser, C_9 . On each side of C_2 holes are drilled through the chassis so that connections from C_2 to the grid and plate prongs on the detector tube socket can pass through. The grid is connected to the stator plates; the plate to the rotor. One end of the grid leak R_3 is soldered to the inner end of L_2 ; the other terminal goes to a lug fastened to the chassis beside the detector tube socket.

Aside from the coupling between the r.f. and detector stages, the arrangement of and method of wiring the parts underneath the chassis is not so critical. Short, direct leads are essential in the r.f. coupling, however. This consists of the radio-frequency choke RFC_1 and the adjustable condenser C_4 . The choke should be mounted as close as possible to the plate prong on the r.f. tube socket, and C_4 must be placed so that the leads to it will be short. Both sides of C_4 must be insulated from the chassis, and it is also advisable to mount the condenser as far from other metal parts as possible to avoid capacity effects to the chassis. A National Type-WGS stand-off insulator is used for this purpose, mounted near the detector-tube socket. The metal base of the insulator should be removed and a single hole drilled in the chassis so a

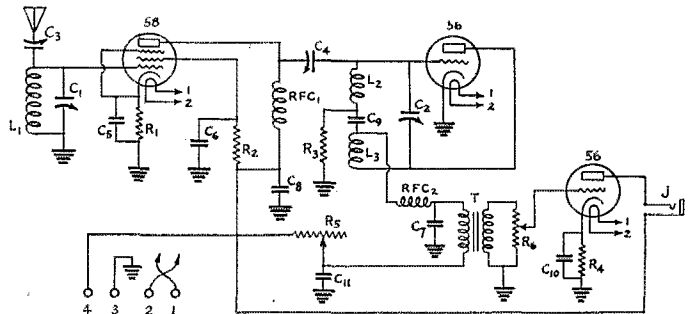

FIG. 13—THE SCHEMATIC CIRCUIT DIAGRAM OF THE SUPER-REGENERATIVE RECEIVER

All "ground" connections on this diagram indicate connections to the metal chassis of the receiver.

- C_1, C_2 —15- μ fd. midget variable condenser (Cardwell Type RT-15 Trimm-Air).
- C_3, C_4 —35- μ fd. midget trimmer condenser (Hammarlund Type EC-35 Equalizer).
- C_5, C_6, C_7, C_8 —0.002- μ fd. mica condenser, midget size (Aerovox Type 1467).
- C_9 —100- μ fd. mica condenser, midget size (Aerovox Type 1467).
- C_{10} —10- μ fd. dry electrolytic condenser, 50-volt rating (Cornell-Dubilier Type ED-3100).
- C_{11} —2- μ fd. dry electrolytic condenser, 200-volt rating (Sprague Type ST-22).
- R_1 —250-ohm 1-watt resistor (Lynch).
- R_2 —50,000-ohm 1-watt resistor (Lynch).
- R_3 —0.1-megohm $\frac{1}{2}$ -watt resistor (I.R.C.).
- R_4 —2000-ohm 1-watt resistor (Lynch).
- R_5, R_6 —500,000-ohm midget potentiometer (Centralab Type 72-106).
- L_1 —8 turns No. 14 enamelled wire, diameter of coil $\frac{1}{2}$ inch, length of coil 1 inch.
- L_2, L_3 —Each 5 turns No. 14 enamelled wire, diameter of coil $\frac{1}{2}$ inch, length of coil $\frac{1}{2}$ inch. The spacing between the two coils is $\frac{1}{2}$ inch.
- RFC_1 —Short-wave choke coil (National Type 100).
- RFC_2 —60-mc. choke coil; 35 turns No. 30 d.s.c. wire on $\frac{1}{2}$ -inch form, length of winding 1 inch (I.C.A. Type 1653).
- T—Audio transformer (Thordarson Type R-260).
- J—Open-circuit jack (Yaxley Type 701).

The following additional components will be needed:

- 1 6-prong Steatite tube socket (National).
- 2 5-prong Steatite tube sockets (National).
- 2 Isolantite stand-off insulators (National Type WGS).
- 3 tube shields (Hammarlund Type TS-50).
- 2 midget condenser couplings (National).
- 1 vernier dial (National Type BM D).
- 4 feet of 4-wire shielded cable.
- 1 4-prong plug or old tube base.

screw can be run through for mounting the insulator. This method of mounting C_4 makes the condenser easily accessible for adjustment.

OPERATING THE RECEIVER

If the construction of the receiver is duplicated and the coils are carefully made to the specifications given, the 56-mc. band will cover approximately the higher-capacity half of the tuning range. In coupling the tuning condensers together, care should be used to see that they are "lined up"; that is, that both reach maximum and minimum capacity at the same dial setting.

The power supply described will give the proper voltages for the tube filaments and plates. Other forms of power supply can be used, however. The filaments must be provided 3 amperes at 2.5 volts, the plates 15 to 20 milliamperes at 200 volts. "B" batteries or an eliminator will be satisfactory for the latter, while a small transformer of the proper rating will handle the filaments.

Assuming that the correct voltages are applied and that the headphones are plugged in, both the volume control and the regeneration control should be set at maximum. There should be the usual hissing sound in the phones. Turning the regeneration control toward minimum (that is, increasing the resistance) should cause the intensity of the hiss to decrease; it may finally stop altogether. Now set C_4 so that the movable plate is just about touching the mica, and set C_3 so that there is about a sixteenth of an inch between the plates. The antenna should be connected to the movable plate of C_3 .

Now turn the tuning dial, covering particularly the higher-capacity half of the tuning range. If a 56-mc. transmitter within a reasonable distance is working it can readily be recognized by the fact that the super-regenerative hiss disappears when the station is tuned in.

Having tuned in a signal, the coupling between the r.f. and detector stages should be adjusted for maximum signal strength. This is done by adjusting the capacity of C_4 . An insulated screw-driver of the type used by radio service men for "trimming" broadcast receivers should be used for this job. Turn the adjusting screw throughout

its range; there should be a rather definite maximum of signal strength at one particular setting. After making an adjustment to C_4 it is advisable to retune the receiver to make certain that the change in capacity at C_4 has not changed the detector tuning. When the proper setting for C_4 has been found, a similar adjustment should be made to C_3 to get the optimum antenna coupling. C_3 also acts to some extent as a trimmer for lining up the r.f. stage with the detector.

The most suitable antenna for the receiver will depend upon the conditions under which it must operate. If the location is high and a short wire will be well above surrounding metal objects such as the frames of steel buildings, a very modest antenna will suffice. For instance, an 8-foot vertical wire located on the second floor of a suburban home will work quite well. It is advisable to make a

short antenna of this sort some multiple of 8 feet in length because such an antenna will be approximately resonant in the 56-mc. band and consequently will give greater signal strength than an untuned wire. In other localities the best antenna usually will be the one which is placed at the highest possible point; it should be vertical if it is possible to make it so. Length is not nearly so important as height; a long horizontal antenna is not generally so efficient as a short vertical one. For this reason it is rarely necessary to have a horizontal wire once the antenna reaches the roof; in common terms, the antenna usually is one which is all "lead-in."

IN CONCLUSION

It might seem that the gear described here is unnecessarily complicated, in view of the fact that the range over which it is possible to communicate is no greater than is to be expected from the simple and cheap transceiver. Nevertheless, this step in the development of 56-mc. apparatus is wholly logical. When a band of frequencies represents a new and unexplored field of interest only to the experimenter, the simplest of equipment will suffice. But when the rank and file of amateurs take over the territory for routine communication, refinements in apparatus become essential.

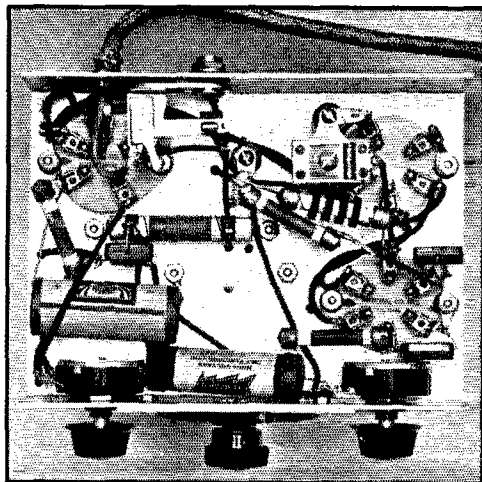

FIG. 15—THIS "BELOW-DECK" VIEW OF THE RECEIVER SHOWS HOW RESISTORS, BY-PASS CONDENSERS AND OTHER COMPONENTS ARE PLACED

Pointers On Noise-Reducing Receiving Antenna Systems

Adapting the "Double-Doublet" To Ham-Band Frequencies

By L. W. Hatry*

Although popularization of so-called "noise-reducing" antenna systems for radio reception has been accompanied by considerable noise, and surrounded by some smoke, most of them differ little from the "lamp-cord" doublet modestly described by W6HM in the Experimenters' Section away back in September 1929 QST. The technic for amateur work is brought up to date in this article by Mr. Hatry, former QST staff member, a gentleman thoroughly experienced in the subject. —EDITOR

OF COURSE, the "noiseless" aerial is mis-named. Passing most of the mis-naming as justifiable colloquialism or language-growth, the correct name still would be "noise-reducing."

The first noise-reducing aerial system consisted of the aerial, defined as the open conductor (the "top") supported practically parallel to the earth, and a shielded vertical or down-lead portion connecting the top to the receiver. This was relatively ineffective, as was its outgrowth, the "completely shielded" aerial. The failure of the plain shielded lead was due to the mis-match of

with the antenna coil of the receiver. But really satisfactory performance was not attained until the shielded lead was used as nearly like a true transmission line as possible, and transformers were applied at both ends.

Those unable to get along with impedance-matching philosophy may make more sense of this equally legitimate explanation: A shielded line has high capacity, or, from a reactance viewpoint, few ohms; whereas an aerial has low capacity, and considerably more ohms reactance. When Ohm's Law is stated in the form $E^2/R=W$, inserting a few figures in the formula quickly shows that for

the same power the fewer ohms call for fewer volts. This is why I mention the lead-in as a low-voltage circuit to which there must be a step-down from the relatively high-voltage aerial. Likewise, most receivers are designed to work from the aerial direct, having relatively high-voltage (high-impedance) input; hence the shielded lead must be stepped-up to the receiver input by means of a trans-

former to give a match and full performance. I speak of the "line" from the aerial circuit to the receiver circuit as a shielded lead because probably the first successful effort at noise reduction was a simple shielded lead-in. However, whether the low-voltage line be a wire surrounded by a metal sheath, or two wires closely paralleled, or a twisted pair—or a combination of these—the result and the basic principles are the same, provided the design is carried out with some skill.

NOISE-REDUCING AERIAL CIRCUITS IN GENERAL

The basic fact utilized in the noise-reducing aerial is that the noises picked up by the aerial, which are radiated from house wiring and elevated a.c. mains, have the typical "local signal" char-

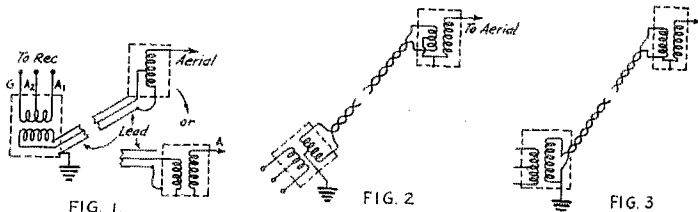

ARRANGEMENTS FOR IMPEDANCE MATCHING TO SIMPLE ANTENNAS, WITH SHIELDED AND TWISTED-PAIR LINES, ARE SHOWN IN FIGS. 1, 2 AND 3

Note that the tapped winding is equivalent to the two-winding transformer, as indicated in Fig. 1.

acteristics that resulted from attaching a low-impedance line (the shielded lead) to a high-impedance line, the horizontal wire. That neither the lead nor the aerial ever approximated a true line in operation is obvious from the fact that nothing was done to eliminate or reduce the various resonant periods (standing waves) occurring in each as the frequency was varied.

The first step in the right direction was toward impedance matching. In other words, the high-voltage top was stepped-down to pass a suitable voltage into the low-voltage shielded lead. The lead was then run direct to the receiver, its standing wave behavior, or free-resonances, being used to act somewhat like a transformer in connection

* Hatry & Young, 203 Ann St., Hartford, Conn.

acteristic of reducing strength in the proportion to the square of the distance of removal. Other things equal, noise from a source of 10 feet away is four times worse than noise from a source 20 feet away. Thus the down-lead of any aerial is likely to be many times closer to the source of noises (wiring of the house, for example) than the top; in fact an average top distance may easily be 60 feet when the average lead-in distance is only 1 foot, and the top, therefore, 360 times freer of noise than the down-lead. Hence the idea of shielding the signal wire so that it could not pick up; while noise pick-up by the shield was directly grounded. But the simple shielded lead is little used to-day, and in its place we have the three basic circuits, variations of which serve for most of the noise-reducing broadcast aeri-als.

Fig. 1 is of the modern shielded lead-in arrangement. Fig. 2 is perhaps the better type of twisted lead-in design and Fig. 3 is simply Fig. 1 with twisted pair replacing the shielded lead-in. I want to step off the line here to stress perhaps an obvious point of noiseless aerial installation which seems to have been ignored completely by manufacturers' instruction sheets, prior articles and most aerial putter-uppers. Following which, gentlemen, we will pass on to the short-wave exhibit.

A basic item in textbook aerial theory is the presumption that the horizontal part is largely inefficient in pick up. In fact, it requires that the radio waves behave indecorously in order to leave any energy in the horizontal wire. We all know that practice departs widely from the basic presumption, simply because radio waves are undignified enough to satisfy the rest of the theory. Nevertheless, the vertical portion of a broadcast-band aerial is very important and does give major results.

Hence, an important detail of aerial design to remember is that if an aerial is connected to earth it does have a vertical section. This statement may seem obvious enough to be silly. Yet Fig. 4 shows a frequently used and recommended circuit. What's wrong with the picture? This: The aerial vertical or "down-lead" or "lead-in" section is now the shielding outside the "line." The fact that the transformer is hung in the air, or that the shield protects the inner conductor, has nothing to do with the fact that Fig. 4's aerial system is reasonably bad off as to noise pick-up even though it is a shielded system. The aerial circuit, of which the shield is a very active part, has the same amount of lead-in in the noise region as before. Nevertheless, Fig. 4 will reduce noise to some extent because the potential gradient of the shield, with the ground at its end, is considerably less than the same length of wire with a relatively high-impedance high-potential primary in its path to ground. This is the same as saying that the

effectiveness of the lead-in as a noise pick-up is directly related to its effective impedance. When it is high in impedance because of inserted units its electric or magnetic coupling to noise sources is more effective; the same amount of current through more ohms impedance gives higher noise voltage.

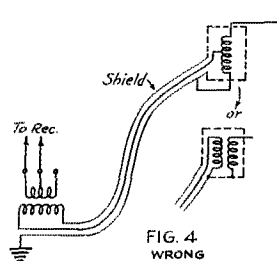

FIG. 4
WRONG

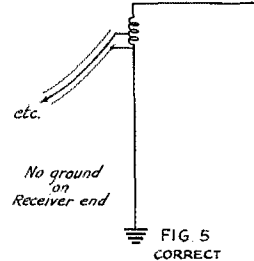

FIG. 5
CORRECT

GROUNDING THE LINE SHEATH IS WRONG, AS SHOWN BY FIG. 4

The correct method is shown in Fig. 5.

Fig. 4 is improved when the effective vertical portion of the aerial is kept out of the noise area, as in Fig. 5, and the shielded line is kept solely to that function and not allowed to mix into the aerial's functions. You have no doubt heard the recommendation of some individuals that the shielded lead be grounded in several places; such complication would not be necessary were the lesson of Figs. 4 and 5 well learned. Likewise, when putting any noiseless aerial system into use keep well in mind that the function of the shielded wire or twisted pair is strictly that of a transmission line, the aerial-ground system being complete in itself and preferably remote from possible sources of noise.

In the circuit of Fig. 2 this advice is not easy to apply. The lead-in of Fig. 2 is a balanced lead designed to pick up nothing, leaving the entire results to accrue from the top of the aerial. Experience has shown that such systems do require longer tops than the ordinary, the "vertical" portion of the aerial contributing too little to the results. Since the lead-in of this system is really dead to pick-up, using the ground at the receiver does no harm except where the receiver is two or three floors from earth. The latter case has a partial vertical portion composed of the piping or radiator system used as "ground"; and it could be improved by a proper vertical portion connected properly on the antenna winding of the aerial top's transformer (Fig. 6).

That results should be widely different with different users of noiseless aerial systems is inevitable, as we have all observed. The error of Fig. 4 is a common one.

DESIGN POINTS

I have spoken of these nets as impedance-matching transformers connected to a transmis-

sion line passing energy from an aerial system to a receiver. Within practical considerations this manner of speech conveys information reasonably close to accurate. Exactly, however, true impedance matching is economically impossible in practice and essentially does not occur. Impedances can be truly and accurately matched at but one frequency and closely matched for a narrow group, graduating to an average poor match throughout a wide range. The purpose of going

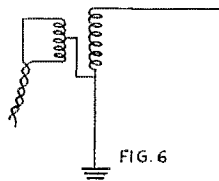

FIG. 6

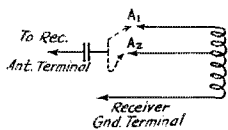

FIG. 7

THE ARRANGEMENT OF FIG. 5 IS ADAPTED TO A BALANCED TWISTED-PAIR LINE AS SHOWN IN FIG. 6

With identical transformers at both ends of the line, a 100- to 200- μ fd. condenser between the transformer terminal and receiver antenna post simulates the capacity of the antenna, as shown in Fig. 7.

into this is to help the experimenter go about the making of his own with some judgment.

When broken into by a transformer a grounded aerial worked at a wavelength higher than its fundamental presents to the transformer an increasingly higher impedance as the transformer progresses from ground to the upper end. (I mean a tapped coil as well as a two-winding unit when I say transformer.) That is why Fig. 5 would not be exactly correct for a transformer designed originally to hang, had it showed the transformer wired in close to earth for convenient mounting on a cellar window or under a porch. This effect is clearest to most, perhaps, if they consider the earthed wire as having capacity, all of which capacity is effective across the transformer next to earth, progressively more being left behind as we move the transformer toward the open end—*reductio ad absurdum* at the open end; no capacity no condenser return circuit, infinite impedance and, of course, negligible results. Which simmers down to the fact that the transformer requires least winding when nearest the actual or effective earth (counterpoise, tin-roof, steel building).

No news is the truth that an aerial has a resonant frequency, whether with an added inductance or not. No system with a resonant point is a constant impedance to all frequencies, else it would not respond best to one. Hence, an aerial system is not a constant impedance and therefore cannot, through a transformer which tries to transfer what it gets, present a constant impedance to a line. The line tries hard to be a constant impedance and will therefore introduce losses which are kept at their lowest by means of the almost-matching transformers.

The antenna matching transformer may be

located where you will in the aerial circuit (say on the ground) if it is built for that location. The resonant frequency for the aerial system plus the transformer should be at either end or the middle of the band; at either end when a certain group of stations must be received best, at the middle if you desire to be fairest to the band as a whole. However, if you wind a transformer for a 50-foot aerial and best performance at the high-frequency end of the band, you have but to lengthen the aerial on the side away from earth to shift the best point toward the middle or the lower-frequency end.

Since the average shielded lead-in gives an effective impedance of from 20 to 50 ohms and the average twisted pair from 40 to 90 ohms, and since the transformer ratio will be proportioned to regard the aerial side as between 10,000 and 20,000 ohms, a turns ratio of between 33- and 14-to-1 will do for the shielded type, and of between 10- and 22-to-1 for the twisted pair. These ratios tend to emphasize the resonance effect. On the other hand, the resonance effect can be reduced, which is the commercial compromise, by using transformer ratios considerably lower and having the line effectively mis-matched over the entire range. The receiver-end transformer (step-up) is a reversal of the antenna-end transformer (step-down) as to connections, design being identical unless the antenna transformer is to be hung near the top of the aerial and well above earth. In the latter case the aerial transformer has a greater step-down ratio from aerial to line than the receiver transformer has step-up from line to receiver. In any case the receiver should have a 100- to 200- μ fd. condenser connected from aerial post to transformer to simulate the capacity of the antenna (Fig. 7).

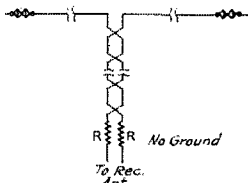

FIG. 8

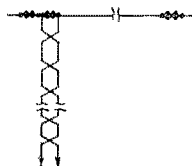

FIG. 9

TRANSPPOSED LINE ARRANGEMENTS FOR SHORT-WAVE RECEPTION ARE ILLUSTRATED IN FIGS. 8 AND 9

The resistors, R, of Fig. 8 serve to broaden the resonance of the system.

Of course, no amount of shielding, and no complication of design, will clear out the remotely picked-up noise. These "noiseless" systems work if the noise is not coming from appreciable distance (which, fortunately, is usual for man-made static) and if the aerial system (complete with down-lead, as in Fig. 5) is remote from nearby noise sources either by virtue of height or re-

moval to the back-lot. In keeping the aerial system free of noise it is not sufficient to raise the aerial above a house and then ground effectively "under the house." To do so is to place the noise source in the direct field of the aerial. For such a case, which is that of the business district or any crowded area, a counterpoise must take the place of ground, and no ordinary ground connection should be made.

SHORT-WAVE NOISE-REDUCING AERIALS

The main trouble of the short-wave "noiseless" aerial has been the wide range of frequencies to be covered. This we solve in most cases by hanging a system which is either restricted to good performance over a narrow band of frequencies or which complicates overall operation by being tuned. For all-wave use, however, we have had various designs of "noiseless aerials" of which most, whether transposition-block systems or users of the twisted-pair lead-in, gave equally good results over limited frequency ranges and equally bad wide-range results.

The short-wave aerials for the amateur or broadcast listener have a doublet top for effective pick-up. One of the first of these consisted of the set-up shown in Fig. 8. R and R were inserted to spoil the resonant point and bring it to the average level of results off aerial resonance. When the horizontal halves are proportioned properly for a given band (about half wavelength total, quarter-wave per half of top), R and R work chiefly to eliminate resonance effects in the line (if it is not very long) and leave the top relatively selective. The Fig. 8 set-up can be effective and satisfactory over a limited band, such as an amateur band, if given regard for electrical proportions; that is, two quarter-wave sections for the top, reasonably close to a half-wave length for the line (or two or three half-wave lengths), and no resistors in use between the line and the usual small primary winding of the receiver.

Where limited-band use is desirable but dimensions and circumstances preclude a half-wave length, or multiples of it for the line, one of two set-ups should be made; a-Zepp, as in Fig. 9, where the line can be a quarter-wave in length (additional line must be added in half-wave sections); or a tuned-circuit and link to the receiver so that a quarter-wave line in Fig. 8 (or $\frac{3}{4}$, or $\frac{5}{4}$) can be effectively matched to the receiver (Fig. 10). For broadcast resonance L and C comprise a low- C circuit for the particular band (keep C near to $25 \mu\text{f.d.}$). L may be tapped for convenience. The link winding to the receiver should have as few turns as satisfactory performance will permit (P to S ratios, say, of 10-to-1 for 1.7 mc., 3-to-1 for 3.5, 6-to-1 for 7, 4-to-1 for 14). In Fig. 10 taps on S are indicated for convenience. Fig. 10 is also applicable to the Zepp of Fig. 9 when the lead-in is at least a half-wave long (or two or three or more half-waves).

From practice I have come to the conclusion that about 30 transpositions per half-wave are sufficient for effective noise reduction. More do not help much and the noise tends to pick up noticeably with fewer.

When the R 's are left off Fig. 8 and a transformer of untuned (by manual control) design, but otherwise of the nature of Fig. 10, is connected between the line and the receiver, we have a set-up recommended for all-wave use. When a twisted lead-in replaces the transposition-block line but gives the same connections, we have approximately the same thing. We also have limited

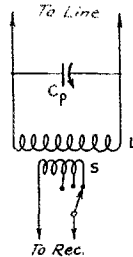

FIG. 10

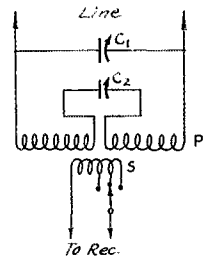

FIG. 11

TUNED SYSTEMS SUCH AS THOSE SHOWN IN FIGS. 10 AND 11 ARE EFFECTIVE BUT SOMEWHAT INCONVENIENT

performance except over one frequency range (sometimes two) of relatively narrow width. That such aerial systems are an improvement over the ordinary sky-wire from a noise viewpoint is frequently enough true. But also they cut down on results on the broad average, leaving from 50 to 60% of the users dissatisfied.

Yet the simple doublet with twisted lead-in or the transposition line can be satisfactory over a very wide frequency range if one has no objection to additional adjustments. A good home-made set-up for all amateur bands would be Fig. 8 with a line of sufficient length so that the length of half the top plus the line totals a half-wave somewhere in the 160-meter band. A transformer is then set up as in Fig. 11, C_1 and C_2 being about 200 to 250 $\mu\text{f.d.}$ each, P being wound as though it were one coil to tune to 1750 kc. but actually split in half. S should have a fifth of the turns of P and be tapped for an 8th and a 10th, and it may be wound on top of P near the center. Operation will be easy. Progressing from 1750 kc. up, C_2 in the center of the coil will be at full capacity until C_1 across has reached minimum and can no longer help, whereupon C_2 is adjusted. As the wave goes further up in frequency and C_1 again reaches minimum, it is time to start the operation over again.

Remember that none of these systems will work as "noiseless" systems if the tops cannot be sufficiently in the clear, up or away, of if the line is allowed to parallel possible noise sources too closely.

A SYSTEM WITH SOME ALL-WAVE PERFORMANCE

Recently designed is an antenna system which has some just cause for the name all-wave. This system is known as the "double-doublet" antenna system. It consists essentially of two doublets mounted in a special manner and with the line tapped onto the doublets off-center to achieve some sort of impedance match for a multiplicity of frequencies. Fig. 12 illustrates the general set-

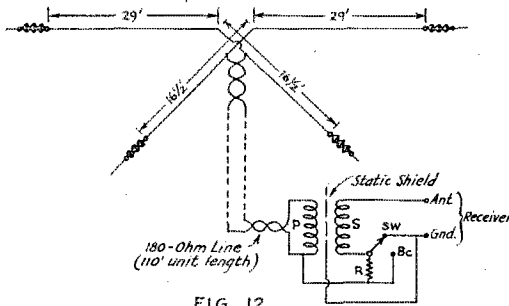

FIG. 12

THE "DOUBLE-DOUBLET" SYSTEM PROVIDES RELATIVELY HIGH RESPONSE OVER A WIDE FREQUENCY RANGE

The "standard" arrangement for general short-wave use has the dimensions shown in Fig. 12 and the response characteristic of Fig. 13. The electrostatic (Faraday) shield is an especially important feature of the transformer. This shield should be of the type described on page 12, December 1933 QST. The transformer turns ratio should be determined experimentally, being dependent on the input circuit of the receiver.

up recommended as standard. From contact with a number of such installations for all-wave use, the writer can testify to the good performance of the system as compared with the usual single-doublet all-wave antenna system.

The effectiveness of the aerial over a wide range of frequencies (approximately 6-to-1) is explained as due to the overlapping resonances of the 29-foot and 16½-foot doublets which result from the set-up of Fig. 12. The longer 29-foot doublet is resonant at about 8 mc. and at its third harmonic of 24 mc. The 16½-foot doublet is resonant at about 14 mc. These resonances combine as shown in Fig. 13 and the antenna behaves accordingly. The performance of a single doublet is similar to that indicated in the curve for the 16½-foot doublet, the peak of the curve varying as to frequency with the dimensions of the top and the transformer used for its line.

The designers stress additional points which contribute to the overall performance of the system. The twisted-pair line is of about 180 ohms impedance. This was chosen as suitable for most all-wave receivers of modern design. It is also a suitable value for the doublets. The transformer that couples the line to the receiver is static-shielded to eliminate capacity

coupling of the line through to the input of the receiver.

The crossing of the two wires that form the aerial top is a phasing necessity. The angle between them seems to be reasonably critical if the intended performance with satisfactory elimination of noise is to be had. The optimum angle can be determined best by trial.

This system is very effective in the elimination of ignition noise on the bands most affected thereby. Since ignition noise seems to travel good distances, this apparent miracle deserves some explanation. The designers suggest that part of the elimination is due to the predominately vertical polarization of ignition-generated waves,

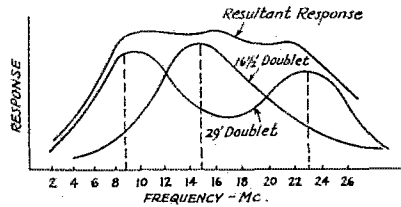

FIG. 13

the horizontal doublet being inefficient for other than horizontally polarized waves. The writer, however, confesses a predilection and stronger faith in the second explanation of the same men: That the twisted line of the system is effectively isolated from the receiver (except electro-magnetically) by the static-shield of the line-to-re-

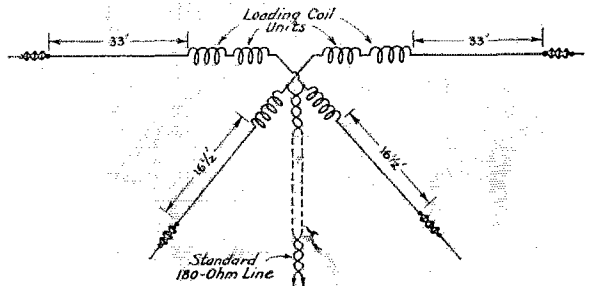

FIG. 14—AN ARRANGEMENT OF THE DOUBLE-DOUBLET SYSTEM WITH LOADING COILS, SUGGESTED FOR PEAK PERFORMANCE AT HAM-BAND FREQUENCIES

In a typical case each loading coil consists of 68 turns of No. 24 enameled wire close-wound on ½-inch diameter form, the length of winding being 1½ inches and the approximate inductance 15 microhenries. The coils should be enclosed in a weather-proof covering, of course. The standard RCA 180-ohm line and the static-shielded matching transformer at the receiver end are the same as for the arrangement of Fig. 12.

receiver transformer. This prevents the line from
(Continued on page 74)

Behind the Scenes With Next Year's Model

The Tale of a New Receiver's Evolution

By J. N. A. Hawkins, W6AAR*

THE recent trend toward all-wave broadcast receivers has aroused much interest among amateurs and others, and many have expressed an interest in how the new developments happened to see the light of day. The principles of design are considered quite mysterious and deeply scientific; so we conducted an investigation among the engineering staffs of receiver manufacturers in order to get the story behind the development of a new model.

Herewith we present the highlights in the development of a typical receiver, "The Dual-Ratio Knee-Action Triple-Hemispheric Multi-Tube Many-Wave Looperdyne."

* * *

President tells Chief Engineer that sales are dropping off on current model so a new one is necessary. As the Chief Draftsman is on his vacation, the Chief Engineer gloomily reflects that he will have to use a new man and have to do all his own calculating. Sends to Purchasing Agent a requisition for a copy of the *Handbook* and a 10-inch slide rule.

President sends memo that compactness and portability are the watchwords. Chief Engineer outlines three-tube design to draftsman, with radical new chassis design and spherical bakelite cabinet. Special dies purchased at cost of \$1,972.34. Sales Manager points out that he forgot the loud speaker. Dies scrapped. Memo from President: Short-wave reception is the coming thing, and compact sets are on the way out. Chief Engineer makes requisition for subscription to *QST*, another *Handbook* and a 16-inch slide rule. Lays out new chassis and designs tuning condensers and coils for 3-to-1 frequency ratio in each band. Draftsman can't read his writing, so provides only a 3-to-1 gear reduction in the tuning dial. Bad intercoupling between various tuning ranges causes continuous dead spots; coil and switching assembly redesigned and shielded. Draftsman points out that new coil assembly won't fit on chassis. Chief Engineer eliminates power transformer and sends memo to President pointing out advantages of new 25Z5 transformerless power supply and full a.c.-d.c. operation. Memo from President points out that 25Z5 rec-

tifier is out, as there are 6,920 type 80 rectifiers still in stock room and must be used up. Chief Engineer lays out new chassis 4 inches wider.

Memo from Sales Manager that RCA is planning new Class-C audio amplifier. Chief Engineer scraps audio channel for Class-C type. RCA designer scraps his layouts of Class-C audio amplifier and plans new Class-D-Prime audio amplifier, after hearing that Philco plans to use it. Philco designer scraps Class-D Prime because it takes 10 watts of driver power to get 7 watts of output to the speaker, and adopts new Majestic "Cold Control."

Cabinets for the new model arrive from Furniture Manufacturer. Chief Engineer suddenly remembers he forgot to notify Furniture Manufacturer that 4 inches were added to the width of the chassis. Chief Engineer eliminates one i.f. stage, the tuned r.f. stage ahead of the first detector, 8 mikes of filter condenser and washes out the audio transformers in favor of resistance coupling. By mounting 16 resistors and 5 by-pass condensers in the half-inch gap between the three-gang condenser and the chassis he manages to squeeze the new layout into the new cabinet.

Service Manager points out that power transformer, three-gang condenser and the filter condensers must be removed to test or replace the 16 resistors or the 5 by-pass condensers. Chief Engineer buys his silence with case of "Old Crow" and a promise to adopt Crosley Shelvador on future models.

President returns from I.R.E. Convention and announces that High Fidelity is the watchword—sensitivity and selectivity must be compromised to obtain it. Design is altered to suit. Class-C audio channel is scrapped for a pair of 845's in Class-A.

Shop error makes i.f. shield can five inches in diameter instead of two-and-a-half. In exchange for past favors in covering up his errors, Chief Engineer writes long memo to President pointing out that large shield can raises *Q* in i.f. transformers and increases gain so that one i.f. stage can be eliminated. President skips involved calculations about large shield cans, tells Shop to eliminate one i.f. stage and add a beat-frequency oscillator for help in finding short-wave stations; also to add an inter-station noise suppressor, as

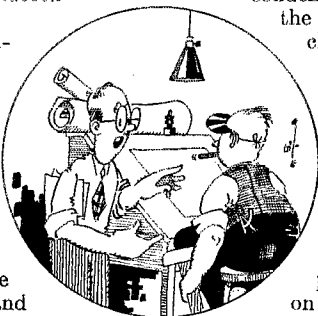

* 2850 19th Ave., San Francisco, Calif

Majestic is reported to have one in their new model. Chief Engineer and Shop Superintendent go into conference and decide that the beat oscillator and the noise suppressor had better be mounted inside of the five-inch i.f. can, and say nothing more about it.

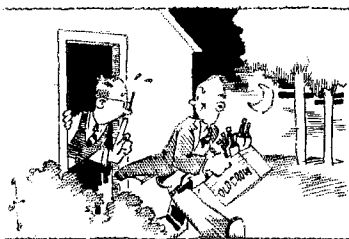

Power transformers arrive from manufacturer with terminals on the side instead of the bottom. After long correspondence with Transformer Manufacturer, Chief Engineer decides to keep mum about it and just mount the transformer underneath the chassis in place of the three-gang condenser, which he mounts on a bracket hung from the loud speaker. Power pack delivers only 200 volts. Transformer Manufacturer points out that Chief Engineer's specifications called for a 400-volt secondary instead of an 800-volt secondary center-tapped, which would be necessary to get 400 volts of output with a full-wave rectifier. After three sleepless nights trying to get the experimental model to operate on the 200 volts supplied by the new power transformer, the Chief Engineer gets the Office Boy (who is a ham in his spare time) to draw him a bridge rectifier circuit.

Sends long memo to President suggesting use of two 25Z5's as bridge rectifier. President is somewhat hazy on the Chief Engineer's involved vector diagrams and, as he has also forgotten about the 6,920 type 80 rectifiers still in stock, he OK's the change and tells the Chief Engineer to make it a long-wave receiver for the export business, which is picking up. Chief Engineer sadly adds another set of r.f. and oscillator coils to cover the range from 400 to 150 kc. and thus is forced to change the intermediate frequency from 260 kc. to 465 kc. Receives memo from Purchasing Agent asking why he changed the intermediate frequency the day after a shipment of five thousand 260-kc. i.f. transformers arrived from the Coil Manufacturer.

First production models show extreme instability and go into oscillation on the least provocation. Since the Foreman of the Sheet Metal Shop does not speak English, the Chief Engineer waves his arms around to show the shape of the new shielding baffle that he wants to put between the i.f. and the first-detector tubes. Misunderstanding him, the Foreman turns out a startling new triple-deck chassis, and orders \$3150 worth of dies to make it. The Chief Engineer has a

drawing made of the new idea and sends it up to the President, pointing out that his new development will probably triple the sensitivity of the set due to the improved shielding.

High pressure Salesman sells the Purchasing Agent a new type of loud speaker. All is well until it is found that the chassis is $\frac{3}{4}$ of an inch too high to allow the speaker and chassis to inhabit the same cabinet at the same time. Chief Engineer saws the bottom out of the cabinet and mounts the chassis $\frac{3}{4}$ of an inch lower. The holes in the front of the cabinet for the tuning, volume and switch controls being now out of line with the control shafts, Chief Engineer finds it necessary to mount the chassis upside down in the cabinet. Sends memo to the President pointing out that new chassis position and bottomless cabinet allow the set to be adjusted and lined up without taking the chassis out of the cabinet. President sends back memo asking how the i.f. tube and the second-detector tube are removed without removing both the chassis and speaker from the cabinet? C. E. makes front of cabinet removable in order to get at tubes.

Assistant Sales Manager writes letter from field to President asking why dealer delivery promised two months ago is not yet being made, and pointing out bitterly that delivery of new lines by three competitors in his territory has already curtailed future orders by 50%. President sends mandatory order to Production Manager to put out new models without further delay and instructs Sales Manager to lower retail price by \$5 and cut dealer discounts in order to compensate for competition. Sales Manager resignedly junks \$6100 worth of

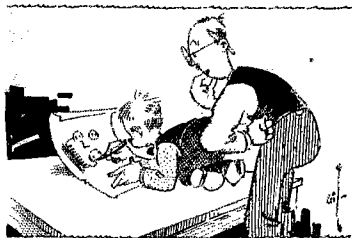

printed literature in connection with big dealer display program on new model in order to feature new price and so informs President. President figures rapidly that 34% more units must now be sold to make up total investment on the new model, but since this represents an increase of only 120% over their net production of last year does not feel too discouraged and prepares to leave on fishing trip to Canada just as Service Manager discovers that last two changes made in assembly by Engineering Department were unreported to him, with result that all servicing literature and instructions must be recalled and new material issued.

(Continued on page 49)

A Medium-Powered 'Phone-C.W. Transmitter With Pentode Power Tubes

30-Watt 'Phone—100-Watt C.W.—Three R.F. Stages—Three Or More Bands

By C. A. Harvey, W1RF* and R. M. Purinton, W1HTM**

THE design of an amateur transmitter capable of delivering 100 watts to the antenna, with crystal control and other features to guarantee the best type of signal, was a complicated task a few years ago. To-day, developments in circuits and new transmitting tubes for amateur use reduce the problem to a comparatively simple one.

The transmitter to be described was built for use principally in the 3500-, 7000- and 14,000-kc. amateur bands with either 'phone or c.w. operation optional. The addition of suitable coils extends the range of the transmitter to the 28-megacycle band, while additional coils and a second crystal make possible operation at 1700 kc. The choice of circuits brought quick selection of the Tri-tet oscillator in the Universal Exciter system already described in several forms in *QST*.¹ Two of the new 50-watt r.f. pentodes² for the final amplifier fulfill the power requirements, operate with excitation efficiency unattainable in triode tubes, do not require neutralization and also make available suppressor-grid modulation for 'phone with a carrier power of 30 watts and 120 watts on peaks.

Prior to construction of the Universal Exciter unit, the final 100-watt amplifier was completed and tests made to determine excitation requirements. Usually, the excitation power required for a triode amplifier stage is approximately 10% of the plate input power to the excited amplifier tube. However, the power required for excitation of the r.f. pentode type tube is only some 2% of

the plate input power and therefore not more than 3.5 watts are needed. The final amplifier with the two tubes operating push-pull was connected to the 59 Tri-tet oscillator with link coupling between the amplifier grid and oscillator plate coils. With the crystal oscillator operated at 3500 kc. the amplifier delivered over 100 watts at 7000 kc. using the 40-meter harmonic from the crystal oscillator for excitation. After considerable debate over the merits of this ultra-simple excitation system for two bands versus the flexible Universal Exciter for all-band operation, the latter arrangement was adopted. The amateur operating on one or two bands and not requiring quick changes to others will find the 59 Tri-tet operating "straight" or at a crystal frequency one-half the transmitted

frequency ample for the excitation of one or two of the 50-watt r.f. pentode tubes.

The Universal Exciter unit is standard in circuit¹ with interchangeable coils and a choice of crystal control or electron control or electron coupling in the oscillator. Two type 59 tubes are used, one as the oscillator and the second as the doubler-amplifier. The final amplifier circuit is a push-pull arrangement with parallel choke feed to each plate to

eliminate the third or middle connection to the plug-in type plate coil.

The modulator uses two Type 45 tubes in push-pull with a single 56 preceding them as a microphone amplifier stage. A good single-button microphone gives ample voltage swing at the secondary of the output transformer. A double-button microphone of low sensitivity makes necessary an additional 56 speech stage, resistance coupled. Tests of both types showed sufficient voltage output with the volume level control well below maximum.

Two power supplies are used with the trans-

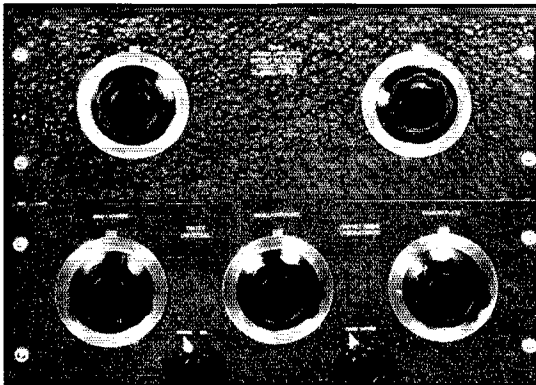

PANEL VIEW OF THE THREE-STAGE TRANSMITTER
It is rated at 100-watt output for c.w., 30-watt for 'phone with suppressor-grid modulation of its push-pull pentode final stage.

* 18 Orchard Road, Brookline, Mass.

** 63 Lake Avenue, Newton Center, Mass.

¹ Issues of Oct. and Nov., 1933. Also Chapter Seven, *The Radio Amateur's Handbook*, 11th edition.

² Introduced in May, 1934, *QST*, circuit data in the June issue.

mitter. One 300-volt unit furnishes current to the 59 oscillator plate and screen, the 59 doubler-buffer screen and to the speech amplifier. The

their screens and 500 volts to the 59 doubler plate. Fig. 1, showing the transmitter circuit, indicates the approximate maximum current values at these voltages.

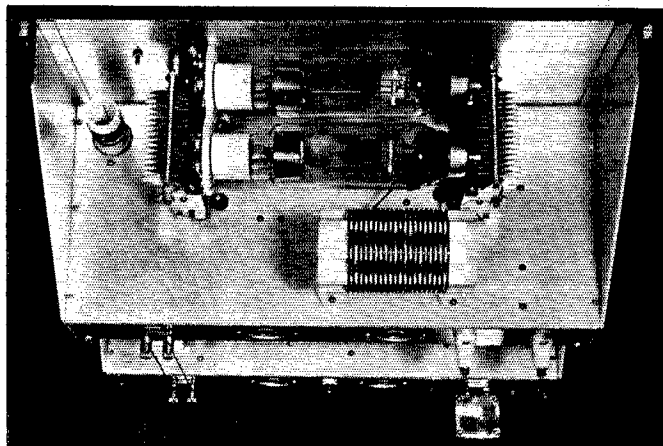

TOP VIEW SHOWING THE PUSH-PULL FINAL STAGE USING A PAIR OF 50-WATT SCREEN-GRID PENTODES

The tuned-grid input circuit is at the left, output tank at the right

other power supply, a standard unit using three 83 tubes in a bridge system,³ furnishes 1000 volts to the final pentode amplifier plates, 300 volts to

³ March 1933 QST. Also p. 151, 11th edition, Handbook.

plane of the filament vertical (plate on edge); or they may be mounted vertically. Shielding is not absolutely necessary with the arrangement shown. R.f. leads should be short and direct.

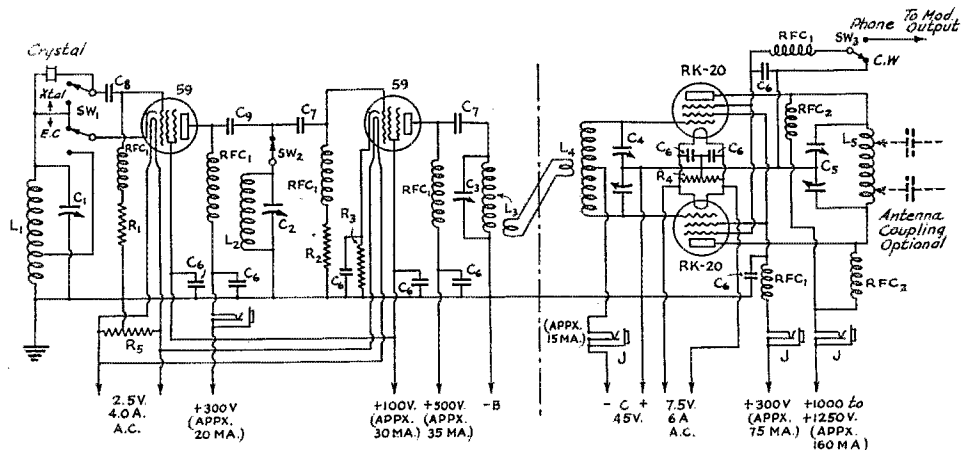

FIG. 1—THE TRANSMITTER R.F. CIRCUIT

- L₁, L₂, L₃, L₄ and L₅—See coil table.
- C₁—365- μ fd. (Cardwell 407 B or equivalent).
- C₂, C₃—150- μ fd. (Cardwell 405 B or equivalent).
- C₄—Split-stator condenser, 130- μ fd. each section (Cardwell 406 BS or equivalent).
- C₅—Split-stator transmitting type, 70- μ fd. each section (Cardwell 413 BS or equivalent).
- RFC₁—2.5-mh. r.f. chokes (Hammarlund or National Type 100).
- RFC₂—Transmitting type r.f. choke (Hammarlund or National or equivalent).
- SW₁—Two-gang two-position switch.
- SW₂—Single-pole single-throw switch.
- SW₃—Single-gang two-position switch.
- C₆—0.002- μ fd.; C₇—100- μ fd.; C₈—250 μ fd.
- C₉—500- μ fd. (All moulded mica type condensers rated at 1000 volts).
- R₁—50,000-ohm; R₂—40,000-ohm; R₃—300-ohm, all 1-watt; R₄—50-ohm c.t.; R₅—20-ohm c.t.
- J—Closed circuit jacks.

CONSTRUCTION

The mechanical assembly of parts in the exciter unit and final amplifier may follow the design shown or may be changed to suit requirements of the individual builder. The amateur who has a Tri-tet assembly may wish to construct only the amplifier. Then again, the high-power station requiring a more efficient driver for the final stage may use the final unit with modifications in mechanical layout to suit the main transmitter. The amateur who is interested only in the amplifier stage can pass over the construction and tuning data covering the Tri-tet exciter assembly.

The coil sockets in the exciter unit should be placed near the tuning condensers with the two 59 tubes between them as shown in the photograph. The two plug caps shown accommodate the cabled leads from the power supply. The switch between is for opening the cathode-to-ground connection of the 59 doubler-buffer tube for keying in this circuit. The binding post terminals at the left in the rear view of the exciter stage are terminals for the link coupling coil at position L_3 and connect to similar terminals on the final amplifier mounted directly above. The crystal plugs into the rear, at the right, as shown in the photograph.

A top view of the final amplifier assembly shows the arrangement of parts and tubes. The layout is unusually simple but, nevertheless, effective. The grid coil is adjacent to the split-stator grid tuning condenser. As may be noted, the tube sockets (which should be Hammarlund or similar because of the arrangement of prong holes) are mounted on brackets attached to the grid tuning condenser frame. The tube plate caps are mounted in fuse clips connected directly to the stator terminals of the plate tuning condenser. The plate coil form plugs into jacks which are a part of the stand-off insulators visible below the coil form. No antenna connections are shown, since any of the conventional arrangements may be used.

TUNING ADJUSTMENTS

In general, the tuning procedure for this transmitter is like that used with all master-oscillator power-amplifier systems. However, certain new features are present, such as suppressor-grid modulation and the low value of excitation demanded by pentode final amplifier. These warrant complete tuning instructions although the adjustment of the transmitter is simple.

Assume, first, that the transmitter is to be used for c.w. on the 7000-kc. band. Reference to the coil table indicates that the oscillator may be used with crystal control or electron coupling at 3500 kc. with coil B_1 at position L_1 , coil A_1 at position L_2 , coil C_3 at position L_3 , coil C_5 at position L_4 and coil C_6 at position L_5 . With this ar-

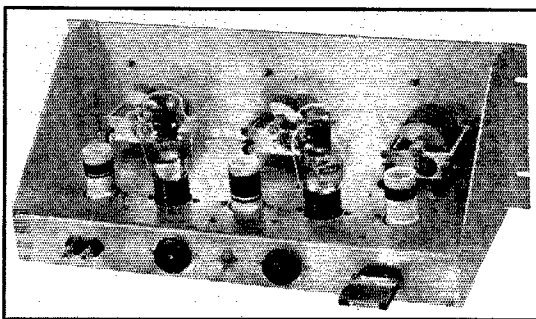

THE EXCITER UNIT IS OF THE UNIVERSAL TYPE, FOLLOWING THE ORIGINAL DESIGN GIVEN IN OCTOBER 1933 QST

The oscillator is at the right, amplifier at the left.

range the oscillator operates at 3500 kc., doubling into the grid circuit of the 59 amplifier tube which passes this frequency along to the grids of the pentode power amplifiers delivering power at 7000 kc. to the antenna. If crystal control is used, Sw_1 will be in the "Crystal" position and Sw_2 will be in the closed position connecting coil A_1 (at position L_2) into the circuit. Sw_3 will be connected to the grounded tap, placing zero potential on the power pentode suppressor grids.

With power connected and with the 1000-volt power supply cut to about 600 volts, C_1 may be set with the plates approximately 25% meshed. Condenser C_2 should next be tuned to make the plate current to the 59 oscillator minimum. Next adjust C_3 to make the 59 amplifier plate current reach its minimum value. Following this adjustment, adjust condenser C_4 to make the power pentode tubes have the highest possible grid current. Next adjust C_5 to make the pentode tubes have the minimum value of plate current. Before connecting the antenna and making excitation adjustments to the final stage, connect a milliammeter in the grid circuit of the final stage and adjust C_1 to the position which provides maximum current in the power pentode grid circuit. Finally, the tuning adjustments described, with the exception of any further adjustment to C_1 , must be repeated. Careful adjustment of each circuit is required for efficient operation.

Following the adjustment of the transmitter, the antenna load may be coupled. For testing it should be a dummy load, which may consist of a coil that will tune to the output frequency with a condenser capacity of approximately 250 $\mu\text{fd.}$, in series with a standard 100-watt 110-volt lamp. Couple the load to the output plate-tank coil and go over the tuning adjustments once more. The 59 oscillator plate current should be about 15 ma., the 59 amplifier a plate current between 30 and 40 ma., the output stage grid current from 15 to 20 ma., and the output stage plate current, with proper load, approximately 160 ma.

So far nothing has been said about the adjust-

ment of screen current to the power pentode tubes. This is relatively unimportant in the 59 oscillator and amplifier but it is an accurate indicator of proper excitation in the RK-20 stage. At 300 volts screen voltage and with 45 volts

considerably higher than the crystal frequency.

'PHONE OPERATION

The circuit of the modulator unit used with the transmitter is shown in Fig. 2. It is a conventional arrangement with 45's push-pull in the output stage. The push-pull stage was selected in place of a single tube to insure adequate modulating voltage across the load resistor without any possibility of distortion. A number of other tube combinations offer possibilities. For instance, a single 47 or 2A5 working into a choke with the audio output voltage applied across a 7500-ohm resistor should work well as the modulator with a single stage using a 56 tube to drive it.

For 'phone operation, Sw_3 should be connected to the modulator output terminal. A meter should be placed in the suppressor circuit at the jack marked *J* in Fig. 2. With the transmitter operating and with modulation the meter should barely show current on speech modulation peaks. The meter deflection should never be greater than 1 ma.

When Sw_3 is connected to the modulator position, a negative bias of 45 volts is applied to the suppressor grids. This negative bias

FIG. 2—THE MODULATION CIRCUIT

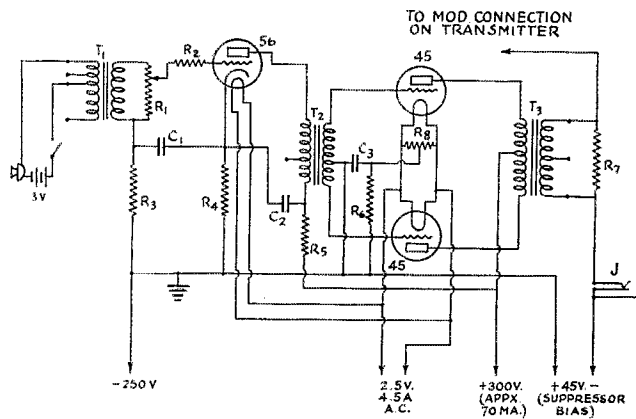

- T₁—Microphone transformer (Delta AD-90 or equivalent).
 T₂—Coupling transformer (Delta AD-91 or equivalent).
 T₃—Coupling transformer (Delta AD-75 or equivalent).
 C₁—0.5- μ fd. 200-volt.
 C₂—2.0- μ fd. 400-volt.
 C₃—1.0- μ fd. 200-volt.
 R₁—500,000-ohm potentiometer.
 R₂, R₃—50,000-ohm 1-watt.
 R₄—2500-ohm 1-watt.
 R₅—10,000-ohm 1-watt.
 R₆—800-ohm 5-watt.
 R₇—10,000-ohm 5-watt.
 R₈—20-ohm c.t.
 J—Closed circuit jack.

negative "C" bias on this stage, the screen-grid current should be approximately 30 ma. for each tube or 60 ma. for the two. If the screen current is higher than this value, excitation should be reduced until the current is normal. At full output of 100 watts, a control-grid direct current of 15 to 18 ma. indicates ample excitation. If the control-grid current is higher than it should be, the excitation to the final stage can be reduced by reducing the plate voltage on the 59 amplifier tube.

Adjustment of the transmitter for other amateur bands should be carried out in the same manner. Reference to the circuit diagram and to the coil table shows that Sw_2 should be open for output frequencies in the 1750-kc. or 3500-kc. amateur bands. The oscillator output coupling for either of these bands is the radio-frequency choke alone, and no tuning adjustments are made to condenser C_2 .

If Sw_1 is placed in the electron-coupled position, condenser C_1 becomes the frequency adjusting element of the transmitter and is highly important, whereas its function with Tri-tet crystal control is to control oscillator excitation, tuning circuit $L_1 C_1$ to a frequency

TABLE I—COIL WINDING DATA

Coil	Diameter	Turns	Tap*	Link Coil Turns	Size Wire	Turn Spacing
A ₁	1 1/8 inch	28	9	4	22 d.s.c.	None
A ₃	1 1/8 "	63	—	6	26 d.s.c.	None
A ₅	1 1/8 "	70	—	6**	28 enam.	None
A ₆	3 1/2 "	68	—	—	16 d.s.c.	None
B ₁	1 1/8 "	15	6	—	22 d.s.c.	None
B ₅	1 1/8 "	42	—	5**	22 d.s.c.	None
B ₆	3 "	38	—	—	12 enam.	Wire dia.
C ₂	1 1/8 "	15	—	2 1/2	22 d.s.c.	None
C ₅	1 1/8 "	23	—	4**	22 d.s.c.	None
C ₆	3 "	21	—	—	12 enam.	Wire dia.
D ₈	1 1/8 "	7	—	2 1/2	22 d.s.c.	Wire dia.
D ₆	1 1/8 "	13	—	4**	22 d.s.c.	Wire dia.
D ₆	3 "	12	—	—	12 enam.	1/4 inch
E ₈	1 1/8 "	2 1/2	—	1	22 d.s.c.	Twice wire dia.
E ₅	1 1/8 "	3	—	1**	22 d.s.c.	Twice wire dia.
E ₆	3 "	5	—	—	12 enam.	3/8 inch.

* Turns from ground end of coil.

** Link coil wound at center of main coil.

Unless otherwise specified, the link coil is wound at the bottom of the tuning coil and is spaced 1/8-inch from it.

Forms:

All 1 1/8-inch forms are Hammarlund Type CF-5-M or equivalent with base for 5-contact tube socket.

All 3-inch forms are General Radio No. 677 U or equivalent.

Coil A₆, 3 1/2-inch diameter bakelite tubing.

TABLE II—COIL COMBINATIONS

Frequency Band	Tri-Tet Exciter			R.F. Pentode Amplifier	
	L ₁	L ₂	L ₃	L ₄	L ₅
1750 -kc.	A ₁	Choke	A ₃	A ₅	A ₆
3500 -kc.	B ₁	Choke	A ₁	B ₅	B ₆
7000 -kc.	B ₁	A ₁	C ₃	C ₅	C ₆
14,000-kc.	B ₁	C ₃	D ₃	D ₅	D ₆
28,000-kc.	B ₁	D ₃	E ₃	E ₅	E ₆

will cause the plate current in the final stage to fall to approximately 60%. It should not vary appreciably from this value (approximately 100 ma.) with modulation.

Thorough tests of the transmitter have been made with a dummy load, and on the air on the 14,000-ke. band. On c.w. transmission, as well as 'phone, it produces all that might be expected of the circuit and tube combination. With no initial neutralization to adjust, and with consequent freedom from interaction, the transmitter is easy to manipulate and produces a clear carrier. With this rig, 'phone transmission at 20 meters has proved to be as productive of DX as with the more complicated 160-watt, Class-B modulated transmitter which it replaced. And the new circuits, and the tubes to go with them, do make the job easier.

Operating Notes

OPERATION on 56 mc. (or work in any amateur band, for that matter) is positively illegal, unless one possesses proper amateur station and operator license authorization from the United States government. In spite of mail-order catalogs and certain magazines which avoid the issue, or indicate to the contrary, licenses positively are required. Under the Communications Act of 1934 there is the possibility of a fine not exceeding \$10,000 or imprisonment not to exceed two years, or both, on conviction of operation without an amateur operator license! Also we note a number of cases in recent *Decisions of the Federal Radio Commission* where individuals have been barred from examination for operator privileges because of such unlawful operation. In addition, at least one amateur's station and operator licenses have been suspended for one year for permitting operation by a man unlicensed and unauthorized.

AUTOMATIC REPEATING for DX relays as suggested in July *QST*, involving the pick-up and retransmission of signals, brings up the problem of making proper identification of stations "at the end of each transmission and at least once in every 15 minutes," as required under Rule 384. To comply with the rules it is necessary only to devise ways where each station "rebroadcasting" in a chain take over the control at the end of each transmission and identify itself.

It is forbidden to sign a false call. Each station in a chain must be identified by its own call signal—and by no other.

The Commission, asked to suggest satisfactory procedure indicates that, if the originating station in a chain signs its call, followed by QRX AS (telegraph), or by voice transmits, THIS IS AMATEUR STATION AT TRANSMITTING TO STAND BY FOR IDENTIFICATION OF THE RE-

LAYING STATION YOU ARE NOW RECEIVING, this followed by a gong or musical note, and this procedure inserted at the end of transmissions (at least once each 15 minutes), and if each other operator in the chain thereupon gives his own station call signal by key or microphone, that will fully meet the government's requirements.

(Continued on page 76)

Rocky Mountain Division Convention

August 25th-26th—Rocky Ford, Colo.

ON to Rocky Ford, Colo., for the convention to be held under the auspices of the Rocky Ford Amateur Radio Association. Those of you who attended last year's convention at Colorado Springs will remember those luscious melons brought over by the Rocky Ford gang. Well, the convention will be held right in the heart of the melon-growing country, and they will be just ripe when we are there. Of course, there is being planned good talks and entertainment for the delegates. The headquarters will be at the Elks' Club, and the best news is the registration fee at \$2.25, which covers lunch and the banquet on Saturday and a lunch the following day. The Colorado Springs gang will also stage an initiation in the R.O.W.H. Remember last year? Make A. H. Haase happy by writing him that you will be there. The address is just Rocky Ford, Colo.

Strays

Lt. Henry B. Harris, 26, research pilot of the M.I.T. meteorological group and well-known to amateur radio for his 56-mc. work on test flights last spring, was instantly killed at the Elmira, N. Y., airport at 7:45 a.m. on June 15th. The rear wheel of a glider-towing automobile in which he was a passenger collapsed, causing the car to overturn. The driver of the car suffered shoulder-blade and rib fractures, but his condition was not dangerous.

The automobile, a large touring car with top down, had towed the glider to the end of the field and the sailplane had taken off. As the brakes were applied, the car skidded on the wet grass. When the driver attempted to turn the automobile the rear wheel collapsed. The car overturned, throwing the driver clear but pinning Harris underneath. He died of a broken neck. Mrs. Frances Harris, mother of the young pilot, was a witness of the disaster.

It was an ironic freak of fate that Lt. Harris, who was one of the best instrument flyers in the country with many hours of experience in "blind" flying and holder of several altitude and cross-country records, should have met his death as the result of so simple an accident as the breaking of a wheel on an old automobile. The New England 56-mc. gang, in particular, admired and respected him; their activities are saddened by his loss.

What the League Is Doing

League Activities, Washington Notes, Board Actions—For Your Information

AS ALL of us know, the A.R.R.L. Board of Directors at its annual meeting made requests of the Federal Radio Commission for changes in certain amateur regulations, so as to secure new privileges for us or relax some of the handicaps on our work. The secretary presented these matters at Washington and we are now happy to say that on June 22d the Commission enacted them. Read on!

Ultra-High Frequencies

For a long time we have wanted the right to roam in the ultra-high-frequency field and, in addition to exploring 30 and 60 mc., find out what 120 and 240 and 480 mc. were like. Effective June 22d, we were given the non-exclusive right to operate at will on any frequency above 110 mc. (any wavelength below 2.727 meters). The new regulation reads as follows:

Rule 374a. The licensee of an amateur station may, subject to change upon further order, operate amateur stations on any frequency above 110,000 kilocycles, without separate licenses therefore, provided:

(1) That such operation in every respect complies with the Commission's rules governing the operation of amateur stations in the amateur service.

(2) That records are maintained of all transmissions in accordance with the provisions of Rule 388.

The Commission also opened these same frequencies to the licensees of special and general experimental stations, experimental broadcasting stations and experimental visual broadcasting stations, for work pertaining to fundamental research. We may operate mobile stations there as well as fixed ones. Now for some really ultra h.f. experimenting! *QST* will endeavor to present some dope. Any contributions?

Mobile Operation

Heretofore we have not been permitted mobile operation except 5-meter work on aircraft. The League requested for amateurs the right to engage in general mobile work on the frequencies above 56 mc. and, as a result, amateur portable-mobile stations are now authorized on those frequencies, including the new region above 110 mc. A portable-mobile station is one so constructed that it may conveniently be moved from one mobile unit to another for communication, and that is, in fact, so moved about from time to time and ordinarily used while in motion. That language exactly covers a ham installation. F.R.C. Rule 368 has been amended to read as follows:

Rule 368. Licenses for mobile stations and portable-mobile stations will not be granted to amateurs for operation

on frequencies below 56,000 kilocycles. However, the licensee of a fixed amateur station may operate portable amateur stations (Rule 192) in accordance with the provisions of Rules 384, 386 and 387; and also portable and portable-mobile amateur stations (Rules 192 and 192a) on authorized amateur frequencies above 56,000 kilocycles in accordance with Rules 384 and 386, but without regard to Rule 387.

Portable operation is not affected by this change and remains possible on the lower frequencies as well. But note that last clause, "but without regard to Rule 387." It is not necessary to notify the radio inspector when engaging in this mobile operation, and it is no longer necessary to notify him when engaging in portable operation on frequencies above 56 mc.! This will be big news for the 5-meter gang, for it eliminates a big nuisance.

Portable and Mobile Procedure

Mobile stations must indicate the call area in which they are operating, the same as portable stations. The Commission provided for this by amending Rule 384 and at the same time made a minor change to specify that the call-area indication must be given each time the call is signed. The new wording:

Rule 384. An operator of an amateur station shall transmit its assigned call at least once during each fifteen minutes of operation and at the end of each transmission. In addition, an operator of an amateur portable or portable-mobile radiotelegraph station shall transmit immediately after the call of the station, the break sign (BT) followed by the number of the amateur call area in which the portable or portable-mobile amateur station is then operating, as for example:

Example 1. Portable or portable-mobile amateur station operating in the third amateur call area calls a fixed amateur station:

W1ABC W1ABC W1ABC DE W2DEF BT3 W2DEF BT3
W2DEF BT3 AR

Example 2. Fixed amateur station answers the portable or portable-mobile amateur station:

W2DEF W2DEF W2DEF DE W1ABC W1ABC W1ABC K

Example 3. Portable or portable-mobile amateur station calls a portable or portable-mobile amateur station:

W3GHI W3GHI W3GHI DE W4JKL BT4 W4JKL BT4
W4JKL BT4 AR

If telephony is used, the call sign of the station shall be followed by an announcement of the amateur call area in which the portable or portable-mobile station is operating.

To eliminate the necessity for notifying the inspector of mobile or portable operation above 56 mc., minor changes were made in Rule 387:

Rule 387. Advance notice of all locations in which portable amateur stations will be operated shall be given by the licensee to the Inspector in Charge of the district in which the station is to be operated. Such notices shall be made by letter or other means prior to any operation contemplated and shall state the station call, name of licensee, the date of proposed operation and the approximate locations, as by

city, town, or county. An amateur station operating under this rule shall not be operated during any period exceeding thirty days without giving further notice to the Inspector in Charge of the radio district in which the station will be operated. This rule does not apply to the operation of portable or portable-mobile amateur stations on frequencies above 56,000 kilocycles authorized to be used by amateur stations. (See Rule 388.)

How's all that, gang? New u.h.f., mobile on our cars, boats and roller skates, and notices to the inspector only for portable operation below 30 mc.!

Simplified Log-Keeping

For a long time we have been growling at the necessity for having two boys and a bookkeeper to be able to keep a station log in legal form, and we have tangled with some radio inspectors who wanted you fellows to make a separate entry every time you switched over to transmitting during a QSO. The League requested the Commission to simplify and clarify its requirements. This the Commission has kindly done, by completely rewriting Rule 386 to read as follows:

Rule 386. Each licensee of an amateur station shall keep an accurate log of station operation to be made available upon request by authorized Government representatives, as follows:

a. The date and time of each transmission. (The date need only be entered once for each day's operation. The expression "time of each transmission" means the time of making a call and need not be repeated during the sequence of communication which immediately follows; however, an entry shall be made in the log when "signing off" so as to show the period during which communication was carried on.)

b. The name of the person manipulating the transmitting key of a radiotelegraph transmitter or the name of the person operating a transmitter of any other type (type A-3 or A-4 emission) with statement as to type of emission. (The name need only be entered once in the log provided the log contains a statement to the effect that all transmissions were made by the person named except where otherwise stated. The name of any other person who operates the station shall be entered in the proper space for his transmissions.)

c. Call letters of the station called. (This entry need not be repeated for calls made to the same station during any sequence of communications provided the time of "signing off" is given.)

d. The input power to the oscillator, or to the final amplifier stage where an oscillator-amplifier transmitter is employed. (This need be entered only once provided the input power is not changed.)

e. The frequency band used. (This information need be entered only once in the log for all transmissions until there is a change in frequency to another amateur band.)

f. The location of a portable or portable-mobile station at the time of each transmission. (This need be entered only once, provided the location of the station is not changed. However, suitable entry shall be made in the log upon changing location, showing the type of vehicle or mobile unit in which the station is operated, and the approximate geographical location of the station at the time of operation.)

g. The message traffic handled. (If record communications are handled in regular message form, a copy of each message sent and received shall be entered in the log or retained on file for at least one year.)

This about explains itself. The date, name of operator, power, frequency band, type of emission and location of a portable or mobile station need be entered only once until there is change. There need be only one entry for each QSO, but

it must state the time of making the first call and the time of signing off, thus showing the period during which communication was carried on. New features are the requirement to maintain copies of messages handled for one year (any kind of copy will do) and to stipulate the type of emission. Easiest way of accomplishing this latter is to use the term A-1 for c.w., A-2 for i.c.w., A-3 for 'phone, and A-4 for television or facsimile if any. Fire the bookkeepers, fellows; we have a common-sense viewpoint on log-keeping now.

More Class-A Examinations

In the west there have been many long stretches where no examinations were held by the inspectors. Take the case of Butte, Montana, for example. An amateur there wanting the Class-A privilege would have to appear in person before the inspector at Seattle or Portland or Minneapolis or Denver—all terrific distances. Yet to many of these cities the inspector has to come twice a year to inspect commercial stations. The League requested the Commission to hold Class-A examinations in these cities under these circumstances. The Commission sharpened its pencil, figured that it would take only a little additional traveling expense to do it, and agreed. Jacksonville, Florida, was in the center of the one bad stretch in the east, and we got that included too. F.R.C. added a new paragraph to their Rule 30a, as follows:

Examinations for commercial and Class A amateur privileges will be conducted not more than twice per year in the following cities, which are not to be construed as examining cities under the rules which apply for Class B and C amateur privileges:

Albuquerque, New Mexico	Jacksonville, Florida
Billings, Montana	Little Rock, Arkansas
Bismarck, North Dakota	Phoenix, Arizona
Boise, Idaho	Salt Lake City, Utah
Butte, Montana	Spokane, Washington

There will be no Class-B examinations at these cities—ordinary amateur privileges are still available under Class-C by mail. 'Phone fellows in these regions who are eligible for Class-A and want to take a whack at it should communicate with the radio inspector for the district in which lies the city of their choice (see listing in *Handbook* or *License Manual*) to learn when the exams will be held.

'N' Prefix for N.C.R.

At its annual meeting the Board approved a request of the Navy Department that, under appropriate rules, the F.R.C. permit the Navy Department to let the N.C.R. fellows use the prefix "N." June 29th the Commission acted on this, the last of our Board matters to come before it, and just a day before it itself went out of existence. It adopted this new rule:

384a. In the case of an amateur licensee whose station is licensed to a regularly commissioned or enlisted member of the United States Naval Reserve, the Commandant of the naval district in which such reservist resides may authorize in his discretion the use of the call letter prefix "N," in lieu of the prefix "W," or "K," assigned in the license issued by the Commission, provided that such "N" prefix shall be used only when operating in the frequency bands 1715-2000 kilocycles and 3500-4000 kilocycles in accordance with instructions to be issued by the Navy Department.

So there you are, N.C.R.! But please note that this is no blanket authorization and that members of N.C.R. do not have the right to start using the prefix of their own volition. It is to be governed by Navy Department regulations. That permission they may give, withhold or cancel in each individual case. We understand that the right to use the prefix will be extended as a "plum" to those who attend drills and make a good record, withheld from those who do not serve loyally, canceled for unsatisfactory performance or infringement of rules. The Navy Department will issue rules for its use. Amongst other things, these rules will prohibit its use in foreign correspondence; it is to be used only when communicating with other "N," "W" and "K" stations.

Speed During his term as director, Barney Fuld of the Hudson Division has been in the habit of returning to New York immediately after the Board meeting, getting on the air at a crack 'phone station, and telling his gang all about the meeting that very night. But for DX performance the records belong to Ralph Gibbons of the Northwestern Division. Three-quarters of an hour after this year's meeting was over, Gib was in the air enroute west. Arriving in Seattle the following evening, he was telling the Northwestern bunch about the meeting in person within 24 hours of its conclusion, and on successive nights spoke to the fellows in Seattle, Tacoma and Spokane to give them the story of what the Board had done. That's action, you'll agree!

The New Law The famous Radio Act of 1927 is no more. Ditto the Federal Radio Commission! On June 9th the Congress passed new legislation, known as the Communications Act of 1934, which on July 1st replaces the F.R.C. with a new Federal Communications Commission of seven members. The new F.C.C. will be in charge of wire telephony and telegraphy as well as radio. It is authorized to divide itself into not more than three divisions to handle specific activities, each division having at least three commissioners as members and being in charge of a director, appointed by the Commission, with each division in full control of its matters except that petitions for review may be filed with the full commission. Except for a few new provisions, generally minor in character and generally relating to broadcasting, the law substantially reenacts the Radio

Act of 1927. The new commission takes over the personnel, funds and records of the old F.R.C. and all the regulations of the latter continue in force until further notice. That is to say, the radio part of the law is almost exactly the same as before and there is no change in any amateur regulation. The League kept in close touch with this legislation as it progressed and is assured that nothing in the new law adversely affects amateur radio.

Madrid Ratification

The International Telecommunication Convention of Madrid, 1932, and the General Radio Regulations annexed thereto, have now been formally ratified by the United States Government and became effective on June 12, 1934, superseding the International Radiotelegraph Convention and General Regulations of Washington, 1927. The text of the Madrid convention and regulations may be purchased from the Superintendent of Documents, Government Printing Office, Washington, at 30¢ per copy.

This treaty applies only to communication with foreign countries that make similar ratifications. The list of foreign countries with whom the treaty was in effect on June 16th is as follows: Australia, Belgium and colonies, Bulgaria, Canada, Czechoslovakia, Denmark, Egypt, Finland, Iceland, British India, Italy and colonies, Japan, Morocco (excepting the Spanish zone), the Netherlands and colonies, and Vatican City State. With other countries the treaty does not apply at this writing.

"Special Arrangements"

Great Britain and British India have informed the United States that they are unable to enter into an arrangement permitting amateurs to handle international third-party messages. That is nothing new, for the amateurs of those countries have always been forbidden by their licenses from handling any messages, even locally. The government of Peru, however, has accepted the proposal which our government put forward in our behalf, and a miniature treaty will be arranged soon. The existing arrangement with Canada has now been extended indefinitely, by an exchange of diplomatic notes which our government undertook at the request of the League. There is no change from the arrangement which has been in effect since 1929 but to refresh your memory we summarize it here; Canadian and United States amateurs may interchange the following kinds of third-party traffic:

- 1) Messages that would not normally be sent by any existing means of electrical communication, and on which no tolls must be charged.
- 2) Messages from other radio stations in isolated points not connected by any regular means of electrical communi-

cation; such messages to be handed to the local office of the telegraph company by the amateur receiving station for transmission to final destination, e.g., messages from expeditions in remote points such as the Arctic, etc.

3) Messages handled by amateur stations in cases of emergency, e.g., floods, etc., where the regular electrical communication systems become interrupted; such messages to be handed to the nearest point on the established commercial telegraph system remaining in operation.

A.R.R.L. on the Air Every Tuesday night at 9 o'clock Central Standard Time, commencing June 12th and running thirteen weeks, the National Broadcasting Company presents "The QST Program" over WEAF and associated stations of the Red Network. Each program dramatizes some outstanding accomplishment of the radio amateur. In addition to being well done and immensely interesting, they are the swellest kind of publicity for ham radio. They are all based on actual incidents of the sort with which we all are familiar, and are written around information supplied by A.R.R.L. Although originally intended to be accompanied by a campaign to interest the public in entering amateur radio, the League has convinced the proponents of the idea that this would be unwise and not conducive to the creation of amateur good-will. The programs therefore appear simply as a tribute to the skill and resourcefulness of the amateur, with no "campaign" at all.

This is a "sustaining" program, not a paid or "sponsored" one. The number of stations broadcasting it varies from week to week, depending upon the time the stations have sold for commercial purposes. A typical line-up embraces WEAF, New York; WTIC, Hartford; WCSH, Portland, Me.; WFBR, Baltimore; WFI, Philadelphia; WTAM, Cleveland; WWJ, Detroit; KYW, Chicago; WWNC, Asheville, N. C.; WSOC, Charlotte, N. C.; WIS, Columbia, S. C.; WJAX, Jacksonville; WIOD, Miami; WFLA, Tampa. If your local station belongs to the N.B.C. Red Network and isn't broadcasting these programs devoted to amateur radio, it is likely they would do so in response to popular request if they do not have the time sold locally. The programs bring amateur work to just that favorable public notice that we always have wished for. Listen to them and see if you don't think they are hot stuff.

Code Examinations

In the past, F.R.C. rules have provided that the code examination for a Class-C amateur applicant must be administered by a person possessing a license from the F.R.C. as a radiotelegraph operator of certain specified grades. The rule gave no recognition to government radiotelegraph operators, who do not need to possess licenses from the Commission. In our territories and possessions and in many remote parts of this

country there are skillful radiotelegraph operators in the service of the various branches of the government, and generally they are in localities where it is difficult to gain contact with a licensed operator. Realizing that a change in the requirements would be of immense help to many amateurs, particularly in Alaska, the League took up the question with F.R.C. and on June 5th secured a modification of the rule, which now permits code examinations by government operators:

407. An applicant for Class-C amateur operator's privileges must have his application signed in the presence of a person authorized to administer oaths, by (1) a licensed radiotelegraph operator other than an amateur operator possessing only the Class C privileges or former temporary amateur class license, or (2) by a person who can show evidence of employment as a radiotelegraph operator in the Government service of the United States. In either case the radiotelegraph code examiner shall attest to the applicant's ability to send and receive messages in plain language in the continental Morse code (5 characters to the word) at a speed of not less than 10 words per minute. The code certification may be omitted if the applicant can show proof of code ability in accordance with the preceding rule.

Examination Changes

Applicants preparing to take the amateur examination should note that their study of the radio law should now be in terms of the Communications Act of 1934 rather than the Radio Act of 1927 and in terms of F.C.C. rather than F.R.C., and that the applying international treaty is now the Madrid Convention of 1932 rather than the Washington Convention of 1927.

Strays

If you can't remember the address of your QSL manager, a lot of trouble in looking it up can be avoided by putting it on the back of the envelope which you send him for mailing cards. When a batch of cards arrives simply turn over the envelope, get the address and mail another one back.

— W5ASG

Referring to the note at the bottom of page 55, May QST, if the substitution suggested is made in the d.c. set, it will be necessary to insert a blocking condenser between the "cold" end of the tickler and ground to avoid shorting the bias battery on the buffer stage.

The RCA tube manual described on page 46 of QST for January, 1934, although priced at twenty-five cents, will be supplied free to individual amateurs writing for copies. A tube chart for wall mounting, Form 1275, also is available. Requests should be addressed to RCA Radiotron Co., Harrison, N. J. A booklet describing amateur transmitting types can be obtained without cost from the RCA-DeForest Amateur Radio Division, 201 North Front Street, Camden, N. J.

A Four-Band Transportable 'Phone and C.W. Transmitter

Power and Stability in an A.C.-Operated 25-Pound Unit That Goes Places

By Frank M. Davis, W9FVM*

EVERY amateur has at some time dreamed of an ideal portable station that he can carry with him wherever he goes. The current popularity of portable 56-mc. apparatus testifies to this urge to get something working away from the home station. However, in many sections of the country 56-mc. stations are scarce and it is necessary to turn to the lower frequency bands if any portable work is to be done.

The writer has had dreams of such an ideal transmitter for some time, and several months ago it was decided to see if something couldn't be done about it. The resulting portable transmitter described herein is the result of design and construction done in spare time in senior engineering college work over a period of several months. While it is not represented that this is the ultimate ideal in portable transmitters, it does

rate units. This decision was furthered by the fact that a good compact portable receiver was already available. Hence the transmitter only was considered in the design.

The requirements are easier to write down than to satisfy. The transmitter must have enough power output to do consistent work. It must be actually portable, *by hand*. It must work efficiently on the four lower frequency bands, 1.75-, 3.5-, 7- and 14-mc. It must be completely self-contained. It must put out a signal of good quality, preferably with crystal control. The tubes used should be inexpensive and obtainable at any radio store in order that no spares need be carried. It must be neat and rugged in construction.

Descriptions of many portable transmitters have been published in these pages, but few of them have made any attempt to give satisfactory 'phone transmission. So another requirement is set down. This transmitter must be capable of complete modulation of the full power output with good quality on any band within its range where 'phone is permitted. The description and photographs indicate the design, and show how well these requirements are met.

THE CIRCUIT

The design of the radio frequency part was not difficult. Experience indicated that r.f. power output of ten to fifteen watts would do very good work. One 46 tube as an r.f. amplifier gives this output easily, and is cheap and easily obtainable for replacement. Since operation on four bands is required, the Tri-tet crystal oscillator is the obvious choice. While good practice ordinarily dictates the use of at least one buffer stage between the oscillator and the modulated amplifier, with the Tri-tet oscillator the buffer action is supplied without resort to a separate buffer stage, an advantageous feature for portable work where the circuit must be pruned down to essentials.

Since it was planned to run the 46 at about 15 to 20 watts input, 8 to 10 watts of audio power would be necessary for complete modulation. The 53 as a Class-B modulator is the logical tube to furnish this amount of power, as it requires only moderate voltage and takes smaller space than any other tube or tubes giving the same output. This is important in keeping the size



"PUSH-TO-TALK" AND OTHER MODERN FEATURES CHARACTERIZE W9FVM'S 25-POUND PACKAGE OF TRANSMITTER

satisfy the requirements listed below in a very satisfactory manner.

For the type of work planned it was decided that the transmitter and receiver should be sepa-

* 1010 No. Sixth St., Monett, Mo.

down. Another 53 with elements connected for Class-A operation serves as the speech amplifier and driver. Any sensitive single-button microphone will drive the modulator to full output. The microphone battery, two flashlight cells, is contained in the set.

Two complete power supplies are used, with sufficient filter to eliminate all audible hum on the carrier. The power supply for the radio-frequency tubes uses a 375-volt transformer, T_1 ; 82 rectifier, a small 20-henry choke and two 8- μ fd. electrolytic condensers. The audio-frequency power supply uses a 325-volt transformer, T_2 ; 80 rectifier, 30-henry choke, and a dual 8- μ fd. electrolytic condenser. This transformer also carries the filaments of all tubes except the 82. Both power transformers are small and light.

MECHANICAL ARRANGEMENT

The transmitter was designed to fit in a small metal carrying case measuring 5 by 10 by 16 inches. The front panel measures about 10 by 16 inches, and there is a sub-panel, 6 by 15 inches, running along the rear, 4 inches from the bottom. It is supported by home-made sheet-metal brackets. All parts are mounted on the panel or sub-panel, and the set is designed to be removed from the carrying case during operation, to facilitate ventilation and cooling.

Attention was given in the design to the distribution of weight in order that the transformers and other heavy parts would not be grouped at one end to make the set end-heavy and hard to carry. As a result of this attention, the center of gravity of the set in the case lies directly below the carrying handle.

The radio frequency part of the circuit is mounted on the left 6 inches of the front panel, making it occupy a space about 5 by 10 by 6 inches, the layout having been tried and found satisfactory in a previous model. The knob at the lower left is on the cathode condenser (excitation control), and the knob to its right controls the oscillator plate condenser. The key plugs into jacks at the bottom of the panel. The 59 oscillator tube mounts horizontally against the front panel just below the condensers, and the coils plug into jacks mounted on small standoffs on the under side of the sub-panel behind the tuning condensers. Between the coils is the mounting for two crystals. The coils may be plugged in from below, and the crystals from behind without

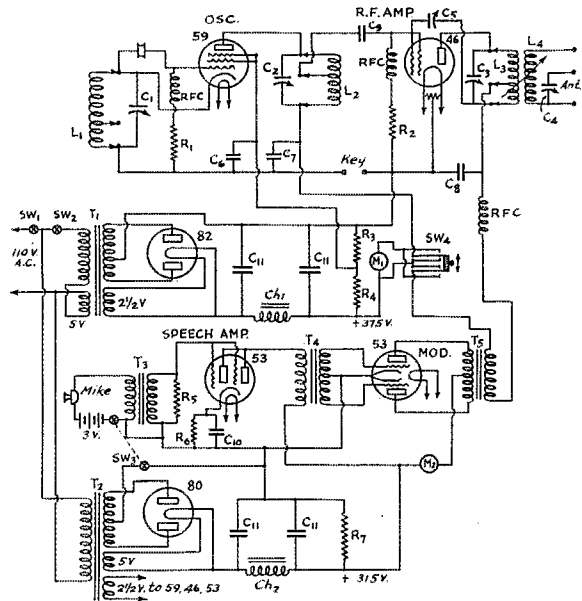

FIG. 1—THE CIRCUIT, COMPLETE WITH MODULATOR AND POWER SUPPLIES

- L_1 —for 160-meter crystal: 38 t. No. 22 d.c.c. $1\frac{3}{4}$ inch dia. for 80-meter crystal: 18 t. No. 14 d.c.c.
- L_2 —160 meters: 30 t. No. 22 d.c.c., with 100- μ fd. fixed condenser. 80 meters: 29 t. No. 18 d.c.c. 40 meters: 12 t. No. 18 d.c.c. 20 meters: 5 t. No. 18 d.c.c.
- L_3 —160 meters: 70 t. No. 22 d.c.c. wire, center tapped. 80 meters: 44 t. No. 18 d.c.c. wire, center tapped. 40 meters: 19 t. No. 14 d.c.c. wire, center tapped. 20 meters: 8 t. No. 14 d.c.c. wire, center tapped.
- L_4 —Antenna coil. 22 t. No. 18 d.c.c. Variable coupling between L_3 and L_4 .

All the above coils are self-supporting and are $1\frac{3}{4}$ -inch diameter. The excitation tap on L_2 is about $\frac{1}{3}$ down the coil from the plate end.

- C_1, C_9 —100- μ fd. midget (Hammarlund or similar).
- C_3 and C_4 —100- μ fd. (National SE-100 or similar).
- C_5 —25- μ fd. midget neutralizing condenser.
- C_6, C_7 —0.006- μ fd. mica (Sangamo or similar).
- C_8 —0.001- μ fd. mica (Sangamo or similar).
- C_9 —250- μ fd. mica (Sangamo or similar).
- C_{10} —25-volt 10- μ fd. electrolytic (Aerovox or similar).
- C_{11} —8- μ fd. 500-volt electrolytic condensers (Sprague or similar).
- R_1 —50,000-ohm 1-watt.
- R_2 —4,000-ohm 1-watt.
- R_3 —10,000-ohm 10-watt.
- R_4 —5,000-ohm 10-watt.
- R_5 —250,000-ohm $\frac{1}{2}$ -watt.
- R_6 —1,000-ohm 1-watt.
- R_7 —25,000-ohm 20-watt.
- T_1 and T_2 —See text.
- T_3 —Single-button microphone transformer.
- T_4 —Class-B input (Collins 754X or similar).
- T_5 —Class-B output (Collins 740Z or similar).
- M_1 —0-150 d.c. milliammeter.
- M_2 —0-100 d.c. milliammeter.
- Ch_1 and Ch_2 —Small replacement-type filter chokes to carry 80 to 100 ma.
- Sw_1 and Sw_2 —S.p.s.t. toggle switches.
- Sw_3 —D.p.s.t. toggle switch.
- Sw_4 —Milliammeter switch, d.p.d.t.

moving the transmitter from its normal operating position.

The 46 r.f. amplifier, with its associated apparatus, is located above the sub-panel. The upper

left-hand knob controls the antenna tuning condenser, and the knob to its right is on the amplifier tank condenser. Directly behind the antenna condenser is the tank coil in its vertical plug-in mounting with the pivoted antenna coil at the top. The tube is located behind the tank condenser. The neutralizing condenser, with the knob convenient at the left end of the set, is mounted under the antenna condenser. The antenna connections are brought through "Micromite" standoff insulators mounted through the panel

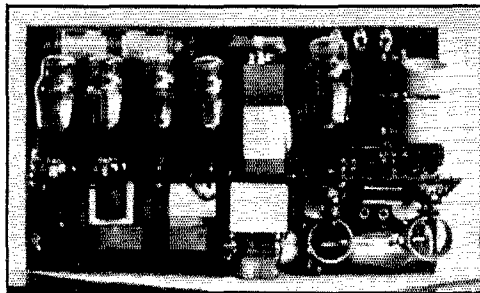

COMPACT? YOU'RE TELLING US!
Six tubes in all, and all that goes with them. The complete details are given in the text.

from behind. The panel is tapped for the mounting screws so that there are no screw heads on the front of the panel. Three terminals are provided so that either series or parallel condenser connection may be used. One antenna coil serves for all bands. Extra tank coils may be used as loading coils, and additional capacity, in the form of small 100- μ fd. fixed condensers, are carried along to help out the antenna condenser when necessary.

The center part of the transmitter comprises the two power supplies. This takes a space about 4 inches along the length of the front panel. The a.f. power transformer is mounted above the sub-panel, with its dual filter condenser behind it and its filter choke above it. The r.f. power transformer is mounted below the sub-panel with the Class-A 53 cathode resistor and by-pass condenser behind it. The power transformers are fastened both to the front panel and to the sub-panel to improve the rigidity.

The remaining space, 6 inches or so, at the right of the set is occupied by rectifier tubes, audio tubes, meters, microphone battery, microphone and Class-B transformers, switches, and part of the power supply filter for the r.f. tubes. On the front panel the left-hand meter is a 0-150 d.c. milliammeter which may be connected in either the 59 or 46 plate circuit by means of the d.p.d.t. switch immediately below it. The meter at the right is a 0-100 d.c. milliammeter permanently connected in the plate supply to the modulator. Just below it is a red-jewel pilot light. At the bottom are three toggle switches. The center

one is the main switch, the left-hand one controls the r.f. power supply, and the right-hand one is a d.p.s.t. switch controlling the a.f. power supply and the microphone battery simultaneously. The microphone plugs into tip jacks at the right end of the panel. At the top center of the panel is a handle for lifting the transmitter in and out of its case.

In the rear view the tubes, from left to right, are: 53 driver, 53 Class-B modulator, 80 rectifier and 82 rectifier. Next comes the dual-8 electrolytic condenser, and to its right the 46 tube and the amplifier tank coil. The microphone battery is at the top of the panel, above the audio tubes, and the audio transformers below the sub-panel. The a.c. line cord plugs into a receptacle just behind the first 53 tube.

This description supplements the pictures to give a general idea of the construction. Because of the compactness and the manner in which the parts are mounted closely together it is impossible for any photograph to show all the details.

The coils are first wound on cardboard tubing of the proper size, doped with Duco cement and then removed from the form. The self-supporting coil is then stuck with more cement on a $\frac{1}{2}$ -inch bakelite strip carrying a G.R.-type plug on each end. Where a third plug is required, a hole is drilled in the strip and tapped for 6-32 thread. The plug is then screwed in and the part projecting through on the other side cut off flush with the strip. When the plug is unscrewed, a soldering lug put on it, and then reinserted, the thickness of the lug prevents the screw from shorting to the coil. These coils are small, light, rugged, and easy to handle. Nine coils, giving crystal-controlled operation on four bands, are normally carried. Coils for using the 59 as an electron-coupled oscillator are also available, and are sometimes used.

IN ACTION

This little transmitter has been in operation now for about three months. It gives about 12 watts output on 40, 80, and 160 meters, and this may be 100% modulated for 'phone work on the two latter bands. Its output on 20 meters is less, about 4 or 5 watts, but is still enough to do surprising work on both 'phone and c.w. The quality on 'phone depends, of course, on the type of microphone, a Universal Model W having been used successfully. The frequency characteristic taken from microphone transformer to antenna terminals shows the response to be 4 db down at 200 cycles on the lower limit, and flat to 9500 cycles (the upper limit of the test audio oscillator). A simple low-pass filter, a sort of tone control, has since been installed to reduce the unnecessary high frequency response.

The transmitter works like it should and does all that can be expected of a transmitter of its power. No loss of efficiency or output seems to

result from the compact assembly. Because of the plug-in coils and the meters permanently in the circuit, only a few seconds are required to change bands.

The transmitter is neutralized in a rather novel manner. Because of the compact construction, there are many chances for feedback and oscillation in the amplifier stage. Since only perfect neutralization will prevent this oscillation, the amplifier is neutralized until it doesn't oscillate. The method is the simplest possible. When the key is up the oscillator tube is "dead," but the amplifier still has its plate voltage. If it is oscillating its plate current will be higher than the six- or eight-milliamperere static current. The neutralizing condenser is then varied with the key up until the amplifier plate current drops to minimum and does not change as the tank condenser is rotated. The antenna should be disconnected during this process. This point of neutralization is as definite and sharp as that obtained by use of a grid milliammeter or vacuum-tube voltmeter. With careful construction and placement of the tap the neutralization need not be changed on any band.

The static plate current of the modulator (both plates) is from 35 to 40 milliamperes, depending on the line voltage. Complete modulation of the carrier is indicated by a modulator plate current of 55 to 60 milliamperes.

Since the key is in the crystal oscillator circuit, the transmitter is completely dead when the key is up. Thus it lends itself readily to the popular "push to talk" phone communication system.

When the transmitter is in its carrying case it has two crystals and nine coils (giving operation in four bands), and the key—all contained inside the case. The microphone, line cord, 60 feet of small flexible antenna wire, a small screw driver and a pair of pliers are carried in the lid. Of course it has some weight; but what amateur would object to carrying 25 pounds in the interest of his hobby? The transmitter alone weighs exactly 19 pounds, and the carrying case and accessories account for the other six pounds.

In conclusion, it should be said that if it were possible to pick the component parts very carefully, such a portable transmitter could be made even more compact without reduction of efficiency. In this instance, however, parts on hand were used when possible and the transmitter was made large enough to accommodate them.

Amateur Radio at World's Fair

SINCE the first 150,000 visitors greeted the renovated A Century of Progress on its opening day last May, a steady stream of sight-seers have poured over the grounds investigating the myriad wonders of the Fair. A goodly proportion of them have come in visual or aural contact

with amateur radio, either at the Radio Amateur Exhibit on the second floor of the Travel and Transport building, or at the special transmitting exhibit installed in the Hall of Science Court.

Those amateurs visiting the Radio Amateur



VIEW OF THE "SPARK" SHACK WHICH IS LOCATED JUST TO THE LEFT OF THE ENTRANCE

This is where the public files their messages to be sent to the modern shack and then received over there as a souvenir copy, etc. W9JO is shown at the key. He is the designer and builder of these two shacks. There is an oscillator concealed within the old spark equipment. The whole gives the appearance of a room being cut in two.

Exhibit are being permitted to operate the 750-watt 7030-ke. transmitter signing W9USA, provided they have their operator tickets with them. It is absolutely necessary to have your license with you if you plan to operate this station when you visit the Fair.

In addition to the manufacturer's display visitors to the exhibit are regaled by several special stunts. Most striking of these is the visitor's souvenir radiogram relay. An old spark transmitter, concealing a modern v.t. oscillator, is located in a booth giving it the appearance of a separate room. Messages are filed at this station, transmitted to the tune of the thumping spark to a receiver located in the "modern" shack, across the room, where they are transcribed on a special souvenir radiogram form and given to the sender as a memento of the Fair.

Work on the remainder of the original project was proceeding apace at the time of writing, the end of June, and by the time this is read all of the originally scheduled transmitters and exhibit stunts will probably be actively functioning. But don't forget to bring that operator's ticket with you when you go to the Fair; you'll need it if you want the sensation of having your fist sign W9USA!

—C.B.D.

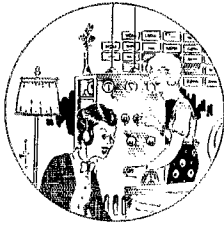

Reserved FOR YL's AND YF's

SOMETIMES We all forget, although usually not for very long, that there are two sexes comprising this world of ours. And through the ages, the masculine has been prone to usurp to itself all authority and all consideration. It took a good many years for women to achieve recognition in the world of affairs, woman's suffrage, and other of their triumphs. But they persevered, and eventually succeeded.

So far, we've managed to keep amateur radio essentially masculine. Oh, there have been a few YL's—perhaps a hundred and fifty or so up to last year. But we've swarmed all over the top of the heap in a plentiful majority.

Now it looks as though all that's going to be changed. The YL's and YF's are going to invade *QST*. In fact, they've already done so. Orders came down from the boss the other day to start a new department in the old mag, one for ladies alone (I mean, only for ladies—don't get me wrong). Shed one bitter tear, gang, for the good ol' days when you could use a kw. spark to shear the hair off your chest without violating any of the conventions. But only one—that's all the time we can spare. We must to work.

Perhaps it's not so bad, after all. As Ed McKinney, W5CJS, says, maybe we ought to get some articles in *QST* "for the women who are liable to be led into matrimony by a ham—and also to encourage more YL operators, whether they be prospective ham brides or not. Such a procedure would accomplish two things: a YL would find out ahead of time what being a ham's wife means and make her choice accordingly—and those women for whom it is too late would be shown how to reconcile themselves to their fate."

Well, here goes. Let's turn the meeting over to the ladies, now, and see what they have to say.

* * *

The YF Has Her Say

By Mrs. Wayland M. Groves, W5DUR

IT ALL started several years ago on a north-bound interurban . . . but we will pass that by. The next thing I knew I was reading letters with foreign postmarks, relating to personal visits to the shacks of KA1HR, VS1AB, VS7AP, and others. Within a year I found myself registered at a divisional convention, where I met those beings I had heard referred to as "hams." Among them

was a jolly little man from Hartford named Herbert, a boy aged thirteen, and a wife (OW, YF, XYL, they say) who had just passed her operator's examination. Why so much attention to the OW who has her ticket, I wondered? She looks every bit the equal in intelligence to those hams with ears warped from wearing the cans.

The next thing I learned was that there are two kinds of licenses: one changes you from a YL to an OW, the other from a BCL to a ham. Of these two, the latter is the harder to obtain. It took two months of dah dit dah dit's (you must not say dot dash, because that is all ruled out, now) for me. When the oscillator was completed and a couple of days spent with it, I expected it to go where most oscillators go that are built for the YF. Truly, I was tired of it after that couple of days, but the OM persisted in dragging it out daily. It got to be as regular as bacon and eggs. After a month of this, we made plans to attend A Century of Progress exposition (which amounted to four days at the World-Wide ham convention and a couple of trips to W9USA at the Travel and Transport building). 'Twas a good trip, at that. A smile broke across my face as we were ready to leave, thinking that I would get to leave dear little oscillator at home. But, to my disappointment, oscillator was loaded on. When I protested, the OM said, "You're at the halfway point. You gotta practice every day now or you'll forget the code you have already learned."

"I'd rather use 'phone anyway," I replied.

The OM retorted, "Do you want to be a sissy?"

I can read every sign along the highway from Texas to Chicago in my sleep, because I had to say them all in dit dah's as we drove along (the OM said it helped to keep them on your mind). You know you are getting good when you can whistle a Burma shave sign as you go by at 50 per.

At Chicago we met all the idols of hamdom I had heard the OM speak of so many times. First, that outstanding personality Hiram Percy Maxim, Fred Schnell, John L. Reinartz, and numerous others.

After getting home, with considerable more code practice to my credit, I turned on the receiver. By all that is holy in ham radio, I was able to copy several CQ's de their calls and a few

words! This was getting interesting. I didn't mind code practice any more. I could see I was getting better daily. At last the OM pronounced my speed 12 w.p.m. Now for the theory. Well, anyone who has crammed for school exams can get enough of that theory down in a couple of weeks so that she won't have to worry. Fact is, I took great pains with my diagrams, etc., and made a higher grade than my OM. Hi!

A trip to Dallas, and the R.I. tuned up the oscillator. I was a bit scared, but when the oscillator got started I knew I could copy that 10 per, and I did on the first trial. Needless to say, the OM was very proud.

After several days of anxious waiting the Class B ticket arrived, and while the OM was at work I turned on the receiver. There was W5CMW CQ'ing. I threw a few switches, made a couple of haywire connections, and gave him a call. Right back he came! I got the call—but say, I thought it was this guy Joe Chaplin who won the world's code speed contest. I guess CMW wasn't there. After requesting a QRS, however, I did very well, and after the QSO I knew that I had been born again into a new world.

Day after day rolled by, and I wondered what could have been wrong with the F.R.C.—not sending me my own call! At last the letter from Washington arrived, and with trembling hands I opened it, realizing that I had a new name, that henceforth I was to be known as W5DUR.

My advice to the OW is to get yourself a ham ticket, and then you can understand why it is sometimes necessary to be late to meals, why wire has to be all over the living room floor, and why it never pays to dust a transmitter.

It seems that the attitude of the YF toward amateur radio is evolved from the ratio existing between the amount of money spent on that 852, or that other new gadget invented by so-and-so, and the distances between her new clothes, which soon become as much of a record as his DX. Yes, alas, the OW must suffer. Those hours spent waiting for the OM to come to meals, contrasted with the speed with which he rushes home to keep a sked. And the sympathy that's deserved by every wife who finds acid on her new rug, and neon tubes in the baby's mouth.

But, oh YF, there's only one remedy, and that's to jump in the water too. You may break a ham of the habit for a little while, but sooner or later he will go back to it. Make it a 50-50 proposition. Make him agree to a few points, like the following:

1. If he plans to locate the set in the living room, reserve at least one corner for the family.
2. When DX parties are thriving, refuse to make sandwiches and coffee after 3 a.m.
3. When you are QSO and haven't time to prepare dinner, make him take you out to dine.

 "One can buy a ham and know precisely what one is getting, but when one takes a ham husband she must go mainly by guess."

In the August, 1931 issue of *QST* there was described the inauguration of the Wives and

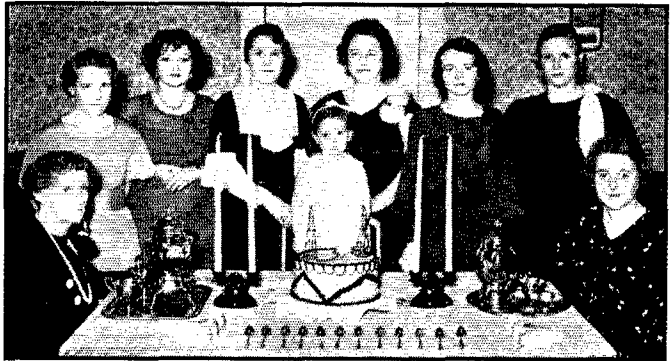

THE WIVES OF RADIO AMATEURS CLUB

Left to right: Mrs. Helmar Bekkelund, parliamentarian; Mrs. T. R. Gentry, chairman, visiting committee; Mrs. J. D. Vance, chairman, membership committee; Mrs. W. I. Abbott, vice-president; Ora Jean Abbott, club mascot; Mrs. Frank M. Corlett, president; Mrs. G. E. Tippett, registrar; Mrs. W. C. Ellis, treasurer; Mrs. Alfred E. Crabtree, secretary.

Mothers of Radio Amateurs Club in Dallas, under the chairmanship of Mrs. Frank M. Corlett, wife of the director of the West Gulf Division. Now nearly four years old, the club has been continuously active since its organization. Last February a third anniversary tea was given at the home of Mrs. W. I. Abbott, to which fifty women, including mothers of radio amateurs, were invited. A magnificent birthday cake, bearing aloft two miniature radio towers and a small station building, decorated in the A.R.R.L. colors, yellow and black, was flanked by yellow tapers in black holders. Black bowls of yellow flowers were used.

 Elsewhere, to our knowledge, Wives and Mothers Clubs patterned after the original Dallas organization have been established. Members of these clubs are cordially invited to send news of their activities to the editor of *QST*, for possible inclusion in this department.

That invitation applies equally to all YL's, XYL's, and RM's, whether already licensed, or interested in becoming licensed, or simply anxious to learn how to get along with the species. Get out your long range ammunition—the cloistered preserves of masculine ham radio have now been made public ground, and it's "Open Season."

Observations on Long-Delay Radio Echoes

An Opportunity for Amateur Cooperation

By J. H. Dellinger*

SPECIAL signals are being transmitted from two European stations for the study of long-delay echoes. The signals and the whole undertaking are adapted to the participation of persons all over the world who have high-frequency receiving sets, no technical training being required.

Long-delay echoes are a most surprising and baffling phenomenon. Mr. J. Hals was listening in Norway, one day in 1927, to telegraphic signals from station PCJJ in Holland on a frequency of about 9600 kc. Some of the signals were followed, after about 3 seconds, by a faint echo or reproduction. Echo signals occurring one-seventh of a second after an emitted signal had been well known, being due to the reception of waves that had travelled all the way around the earth. But the discovery of echoes after a materially greater interval than a seventh of a second immediately raised the puzzling question of where such an echo could come from.

The phenomenon has been verified in a few scattered observations by Dutch, British, and French engineers. Echoes have been heard from 1 to 30 seconds after the emitted signal. Not enough is known, however, to determine what causes the echo signals nor how they are propagated. Two theories have been proposed. One, by Dr. C. Stormer of Norway, considers that there are streams of electrons in space some hundreds of thousands of miles out from the earth's equator, converging in a vast toroid upon the magnetic poles of the earth, and accounting for the aurora borealis or northern lights. Dr. Stormer supposes that the signals are reflected from these electron streams in space. The other theory, by Dr. B. Van der Pol and Professor E. V. Appleton, considers that these echoes are due to a slowing up and reflection of the waves by a peculiar distribution of ionization in the very high levels of the ionosphere (that portion of the atmosphere, 65 miles and more above the surface of the earth, which is responsible for all long-distance radio transmission).

The British Broadcasting Corporation through its magazine, *World-Radio*, and with the aid of Professor Appleton, has just inaugurated a world-wide endeavor to learn more about these long-delay echoes. Special emissions are provided from two high-power high-frequency stations to facilitate observations by anyone who cares to

listen with a high-frequency receiving set. Listeners in all parts of the world have been enrolled in the endeavor, over 10,000 of them in Great Britain. It seems likely that information of unique value to science will result, and an orderly explanation of the curious phenomenon developed, when definite data are secured on the frequencies and the times of day and season at which these echoes occur, their intensities, the area over which a given echo is heard, their relation to magnetic storms, sunspots, etc.

THE SPECIAL TRANSMISSIONS

The stations transmitting the special signals are GSB, Daventry, England, and HBL, Geneva, Switzerland (the League of Nations station). The GSB signals are transmitted on 9510 kc., with a tone or modulation of 1000 cycles per second, each Sunday, Tuesday, and Thursday, from 3:25 to 3:55 a.m., Eastern Standard Time. The HBL signals are transmitted on 6675 kc., modulated continuous waves, each Sunday, Wednesday and Friday, from 6:00 to 6:30 a.m., E.S.T. Each transmission consists of a five-minute adjusting period (GSB using phonograph music, and HBL using its call letters in code repeated) followed by the letters of the alphabet in code, spaced a minute apart. Thus, for instance, GSB transmits the letter "A" in code at 3:30, and after a minute of silence the letter "B" at 3:31, then the letter "C" at 3:32, etc., finishing with letter "Z" at 3:55. During the one-minute intervals between signals the observers listen for echoes and observe the elapsed time in seconds with a watch having a second hand. It should be noted that the GSB signals are receivable with a receiving set as used for receiving broadcast programs, but the HBL signals are unmodulated c.w. and, therefore, require an oscillating receiving set.

I would be very glad to have any successful reception of long-delay echoes in the United States reported to me, and will relay the information to the British authorities who are coordinating the investigation for the world as a whole. Observers should give the identifying letter of the signal observed, the time to the nearest second at which the direct signal was heard, the time to the nearest second at which the echo was heard, an estimate of the relative intensities of direct signal and echo, a description of the sharpness or apparent shape of the echo, and any pertinent information on interference, fading of signals, etc.

(Continued on page 85)

*Chief, Radio Section, U. S. Bureau of Standards, Washington, D. C.

H A M D O M



A STOCK-BROKER took to ham radio; but there was a background that provided the reason. In 1902 Paul H. Davis, now 45, senior partner of Paul H. Davis & Co., past-president of the Chicago Stock Exchange, built an untuned "transmitter" using a Kidder medical induction coil excited by a bank of salammoniac cells and transmitted 30 feet to a coherer in a neighbor's home. In 1909-1910 a small spark set was built at the University of Chicago with Coleman Clark (now champion ping pong player). Then for ten years Paul's interest in radio was purely academic, but with the advent of broadcasting the usual set-building commenced. In 1925 he was elected vice-president of the C.R.T.A. In 1930 his eldest son, W9ADU, went to the Arctic with MacMillan, and a transmitter was built to keep in touch with him. Now there is a 1/2-kw. c.c. job on 3.5 and 7, and a 200-watt 1.7-mc. 'phone at W9GES-W9BT. The current interest is 56 mc. For two years he has represented A Century of Progress in connection with amateur activities. Added to W9ADU there's a daughter who knows the code,



acquired the nickname "Panther" and the seed of the South Sea nostalgia that now grips him. He shipped with four Britishers in the 65 ft. ketch "Vanora" and roamed the Pacific—Fiji, Pago Pago, Suva, Brunei, Singapore, Pulau Bukum and Sebang, Mauritius, and then Durban. Now he's back, but we strongly suspect that Boston, New York, Hartford are just further ports of call for this ham who went to see for himself the places he once worked.



AMONG the claims to fame of Ed Harris of Hugo, Oklahoma, in addition to the dominance of his call, W5TW,

over southwestern airways, are his double filament test tube audion, and the fact that he has a copy of every *QST* ever printed. Now 29, he started in wireless in 1912 with a spark coil and crystal detector. In 1919 when the Navy Department said "Go!" in he went with a 1-kw. rotary spark gap 'n' everything. In the autumn of '20 this gave way to the ubiquitous "5 watter," followed by a continuous series of displacements until now there is a 100-watt five-stage c.c. job. But if you listen much on 40 meters you're probably already well aware of that.



Scrpps-Howard Photo

and a 9-year-old son who's boning for the license exam—even Mrs. Davis likes to sit in when the station's on the air. Kenilworth boasts at least one 100% radio-minded family!

THOSE who roam the world with key and microphone will feel a sympathetic envy for J. L. A. McLaughlin, just

returned from two leisurely years spent circumnavigating the southern girdle of the world. He, too, once visited the remote spots of the earth in spirit, as 2AKP. In mid-1932, having tired of such mundane pursuits as being chief engineer of radio stations and receiver manufacturers (old timers will recall his original one-control neutrodyne and super) or serving as assistant to the art director of the old Roxy theatre, he hied himself westward to Tahiti. There he

BOY SCOUTS and amateur radio constitute a fortunate combination, as has been discovered by national scout executives recently. W. Howard Moffat, W5CWC, has known this for several years. An Eagle scout, mate of the local Sea Scout ship, as well as a radio amateur since 1920 and an ensign in the NCR, he has combined the activities for a number of years past, notably in providing amateur radio communication at summer scout camps in the Choctaw area, down near Meridian, Mississippi. Moffat started the idea in 1925, as portable 5AGM, which was operated for two seasons at Camp Binachi. College interfered for four years; now W5CWC links Binachi and Meridian each year.



Typical Technical Questions Answered

Class-A Plate Swing—Monitor On Harmonics—Unbalanced R.F. in Push-Pull— Oscillating T.R.F.—Universal Antenna Coupler Quirks

Q. No. 1:

How may the maximum plate voltage swing of a Class-A amplifier be computed?

A. No. 1:

One method of determining this value approximately, is to take the square root of the product of the rated load resistance, and undistorted power output of the tube.

Example:

Type '45 tube.

Plate voltage, 275 volts.

Optimum load resistance, 4600 ohms.

Power output, 2 watts.

Maximum r.m.s. voltage developed across the load = $\sqrt{4600 \times 2} = 96$ volts r.m.s. The peak value is obtained by multiplying this value by 1.4, which gives 134 volts for the peak swing either side of the operating point (total swing, 268 volts).

Q. No. 2:

Will you please make clear to me how an electron-coupled frequency meter can be used as a monitor when the coil in the meter is wound for only one band? For instance, how is it possible to hear a 7000-kc. signal using a monitor with a 1750-kc. coil?

A. No. 2:

The reason that a 7000-kc. signal may be heard in a monitor tuned to 1750 kc. is that the fourth harmonic of the monitor oscillator heterodynes the 7000-kc. signal to produce the beat note in the plate circuit of the monitor. A 1750-kc. tuned circuit will have appreciable, though small, impedance at the higher frequencies and will, therefore, detect signals at its harmonics if they are of sufficient strength.

Q. No. 3:

I have constructed a push-pull self-excited transmitter, but have encountered considerable trouble in "balancing" it. A neon bulb touched at either end shows considerable more r.f. at one end than at the other. All wiring is perfectly symmetrical, and switching the tubes causes no change in the condition. A single-stator tank condenser is used. What is the cause of this?

A. No. 3:

Unless one side of the tank is near a grounded conductor (such as shielding), if the wiring is perfectly symmetrical, the coil center-tap properly located and the tubes in good condition, it is

probable that the circuit is really "balanced" satisfactorily even though the neon lamp test does not indicate that this is true. The reason is that the hand capacity to one side of the single-stator tank condenser may be sufficiently different from that to the other side to cause the neon bulb to give a misleading indication.

Q. No. 4:

Having built the three-tube autodyne receiver described in *QST* for January 1933, and also in the last two editions of *The Radio Amateur's Handbook* (p. 57, 11th edition), I have experienced trouble from the r.f. amplifier which oscillates when the r.f. gain control is turned down. Upon investigation, I find that the screen voltage varies from 50 to 175 volts as the r.f. gain control is varied from minimum to maximum. Why does the screen voltage vary and what causes the instability of the r.f. amplifier?

A. No. 4:

Although we did not run into trouble with oscillation in the original model of this receiver, it is quite possible that variation in screen voltage might be experienced. Such a variation might, in certain instances, cause instability of the amplifier. As the gain control is varied, the grid bias of the r.f. tube is varied, which will cause a change in screen current. This change in current will cause a proportional change in the voltage drop across the series voltage dropping resistor which in turn will cause a variation in screen voltage. This variation might be practically eliminated by securing the screen voltage from the voltage divider. This could be done by substituting two 7000-ohm resistors for the 14,000-ohm resistor R_5 and connecting the screen to the junction of the two 7000-ohm resistors.

Q. No. 5:

May the antenna and feeder lengths be of any convenient dimensions when used with the universal antenna coupler as described in *QST* for February?

A. No. 5:

It should be possible to put power into an antenna system of any antenna length and feeder length, within reason in respect to the frequency used. However, as the original article definitely states, the radiating properties of an antenna system still depend upon the usual requirements for a good radiator, irrespective of the type of coupling. For best radiating properties, the

antenna proper should be cut and erected as carefully as with other coupling systems. It is only in the feeders, such as those of a Zepp system, that the dimensions are less critical. With the more usual type of coupling, tuned feeders should be cut in approximate lengths of quarter-waves. This, however, becomes unnecessary when using the impedance matching network, and the feeder length may be the most convenient.

Q. No. 6:

When using the universal antenna coupling network, the final amplifier oscillates. What may the trouble be?

A. No. 6: *

It may be that with the network improperly adjusted, capacities are introduced which disturb the neutralization of the amplifier. When the network has been finally adjusted, however, it should appear as a pure resistance across the output tank circuit and should not disturb the neutralization of the amplifier.

--D. H. M.

Visit the Clubs

A GOOD many hundred amateur radio clubs throughout the United States and Canada are affiliated with A.R.R.L. At headquarters we have recorded the addresses of these clubs, their places and times of meeting. Clubs are splendid places to get acquainted with other amateurs and to participate in interesting discussions on amateur radio. Do you want to be put in touch with a club in your vicinity? Would you like to attend a club meeting in another city you are visiting? Address the Communications Manager (enclosing 3¢ stamp, please) for data on Affiliated Clubs in your vicinity.

Saskatchewan Hamfest Well Attended

IN THE U. S. we outnumber Canadian hams by more than thirty to one. When as many as 75 VE's attend a hamfest at Moose Jaw, Saskatchewan, it means something. From the four corners of the province they came, on June 7th, to the Moose Jaw Amateur Radio Club Hamfest, to make the affair one of the most rousing ever held in that region.

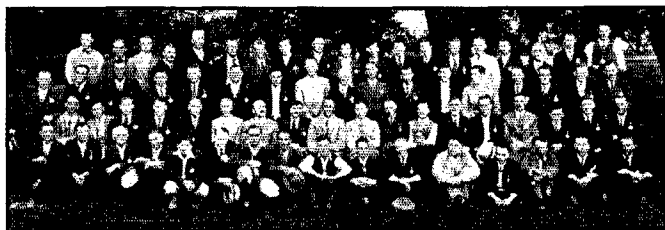

Varied entertainment was provided throughout the day, the routine skillfully organized by Allan Saunders, president of the club, J. Heddle Sinclair, secretary-treasurer, and an entertainment committee comprising Fred Ward, Austin Capper, and Tom Holtby. The morning hours were given over to registration and a general get-together, in which much of the pent-up steam of many hamfestless months was released. Luncheon put a period to this phase of the proceedings.

At two o'clock in the afternoon several groups went their respective ways, some to the Natorium, some to the Wild Animal Park. Later the members gathered in a body to visit the National Light and Power Company's plant, and, still later, inspect the transmitting studio and remote control equipment of CHAB. At this point we must not forget the exhibit of amateur gear in the C.P.R. dining hall, where more than 100 pieces of apparatus, receivers, monitors, freq-meters, from 1-tube DX'ers to multi-stage jobs, were displayed by the proud owners.

The evening schedule was a heavy one. W. R. Pottle, chief radio inspector for Saskatchewan, traced the development of radio. W. Skaife, of Regina, VE4EL and SCM for Saskatchewan, talked on traffic. J. C. Stephen, local Department of Marine radio inspector, told of amateur aid to radio science. Harold D. Tee, Marine Department inspector for Saskatoon, boosted his home area.

Following the royal toast, proposed by W. R. Pottle, Heddle Sinclair gave "To the Visitors"; the reply came from Ed Swain of Regina. William Rogers proposed a toast to the c.w. men; not to be outdone, E. J. Mehlhoff toasted the 'phone men. Edward Holmes eventually concluded with a tribute to those who had passed on, "To Silent Keys."

The Moose Jaw gang feel justly proud of their success. After all, they say they had a *real* depression in Saskatchewan. And the fact that this affair was the biggest one ever certainly proves something or other, they feel.

--C. B. D.

Strays

From a newspaper clipping sent in by W. G. Blaha of Cleveland, we learn that different sounds made in laughing indicate varying degrees of mirth. The syllable "hi" (pronounced "high"), for instance, shows a dislike of laughter and a desire to avoid it. Must be some truth in it, for most of the "hi hi" performances heard on the 'phone bands give the casual listener just that impression.



Stabilized 56-Mc. Transmitters

In a recent program of experimental work on 56-mc. transmitters carried out by *QST*'s Technical Staff, considerable work was done in the attempt to obtain a high degree of stability with a single transmitting tube. The circuits showing

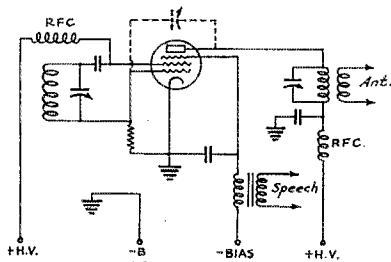

FIG. 1.

greatest promise followed closely those described by J. C. W. Drabble and R. A. Yeo in *The Wireless Engineer & Experimental Wireless* for December, 1933. In general the arrangements consisted of an electron-coupled oscillator with the suppressor grid operated at ground r.f. potential and supplied with the modulating voltage. The input circuit of the oscillator was operated either at output frequency (in which case the tube was

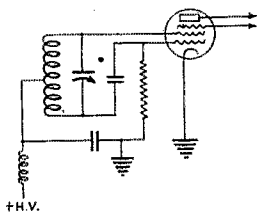

FIG. 2.

neutralized) or at one-half or one-third the output frequency. The complete freedom from frequency modulation suggested by the authors above-mentioned was not attained. Nevertheless, the circuits showed a considerable improvement over the ordinary modulated oscillator and doubtless hold some promise for the future. They present a splendid field for experiment.

The input circuit of the transmitter may be either the Colpitts of Fig. 1 or the Hartley of Fig. 2. Both appear to be effective. The remaining circuit features and constants represent an ap-

proach to normal practice, and need no further mention. The use of a suppressor at "ground" r.f. potential and the screen above ground would seem to be desirable in order to avoid having any cathode current common both to the input and output circuits of the transmitter—as is the case in the normal electron-coupled circuit of to-day. The tubes used with some success included the Types 58, 59, RK20.

—R. A. H.

An Ingenious Bug

A home-made bug which eliminates the machine shop, mechanical engineers, cranes, etc., which are usually required in the making of even the simplest home-made bug, is being used here at W6AVQ; and although it has a rather strange and startling appearance, it works quite decently and can be made in any well-equipped kitchen or bathroom with very little struggle.

Briefly, the idea is to use a straight key set up on its right side with a couple of angles for the main part of the animal, and screw the vibrating spring onto the end of the arm. Thus in one swoop the tough question of bearings, main arm and one of the springs is disposed of.

Fig. 3 gives all the necessary details. The universal clips used for weights are easily adjustable for various speeds. They are the type our Hartleys used to bristle with before Hull got on the job. The angles are from the 5 & 10. The light spring carrying the dot contact is a prong contact from a Benjamin spring socket. Almost any light spring would do here. The vibrator spring is a one-inch piece of half-inch corset stay, with one-quarter inch bent at a right angle (it must be bent slowly as it is brittle) and drilled or punched at the unbent end for the back adjustment screw on the key. It is clamped under the locknut on this screw. The screw is lock-nutted to the bent end of the vibrator spring; a hole should be punched and the vibrating arm fastened securely. The rubber band balances the tension of spring near the dash contact so that the arm comes back to a middle position after a flock of dots. A light spring under the adjusting screw at the back of the key would look less queer, undoubtedly. The two sets of contacts should, of course, be connected in parallel.

It was necessary to solder over each of the contacts on the dash end, making a solder to solder

contact, as the high resistance of whatever Signal uses in his contacts made the dashes sound different from the dots (which have a low resistance path) in my monitor. A piece of cork glued to the under side of the regular knob makes the dot knob.

The adjustments of the thing call for much cut-and-try. The rubber band, the dash spring and the

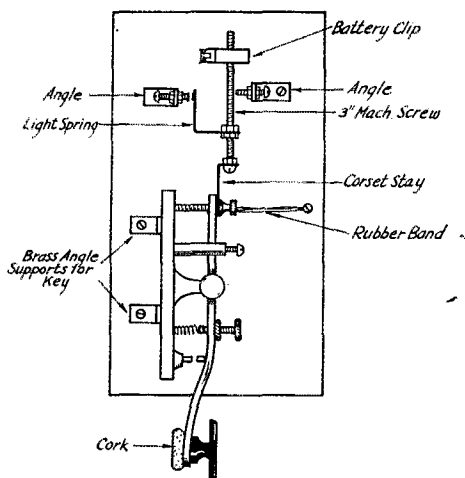

FIG. 3—A BUG KEY MADE FROM AN ORDINARY HAND KEY

set screw at the back of the key are adjusted for about one-eighth-inch swing on the dot side and one-sixteenth on the dash side, with enough tension on each spring to bring the bar back firmly to the middle position. With the bar all the way over in the dot position, the contacts should touch with a slight tension on the spring carrying the dot contact. This makes a heavy dot. But the adjustments of home-made bugs have been explained many times; there is nothing different about this bug except the use of the straight key, which really makes the home-made bug a simple matter any ham can build. No more glass arms. . . .

—Frank Sullivan, W6AVQ

Magnets for the Velocity Microphone

Where to get permanent magnets for home-made velocity microphones? Here is one answer, supplied by Paul R. Smith, W8FHB, Bradner, Ohio:

"A recent issue of *QST*¹ gave data concerning the construction and operation of a ham-built velocity microphone of the permanent magnet type. This was the very thing I had been looking for, but upon invoicing my stock of parts I found nothing that would be of any value. One day,

¹ Velocity Microphones—The Permanent Magnet Type February, 1933, *QST*.

quite by accident, I found a substitute which is easy to construct and at the same time very rugged. It is the last word in simplicity since there is no machining of parts.

"The drawing of Fig. 4 shows the construction of a microphone using a permanent magnet of a special type—a drag-magnet taken from a watt-hour meter. Magnets of this type should be easily obtained by hams who are on good terms with a power company. The spacing between the poles is originally about one-eighth inch, which is not wide enough for the ribbon. Therefore the poles must be separated far enough to admit a 1/4-inch bakelite strip to which the ribbon is fastened by the washer-nut combinations at each end. The mechanical tension of the magnet is ample to hold the strip permanently in position.

"An improvement can be made by drilling the strip full of holes to allow free passage of air past the ribbon. These should be as large and as close together as possible without endangering the mechanical strength of the strip. A tinfoil ribbon is in use at W8FHB. It can be made quite accurately if a little time and patience are used in shaping it.

"No means of checking the quality is available here except the usual ham method of hooking it

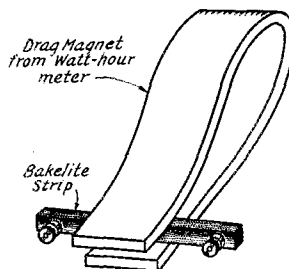

FIG. 4—SIMPLE VELOCITY MICROPHONE USING A DRAG-MAGNET FROM A WATT-HOUR METER

The ribbon, not shown, is suspended between the machine screws at the ends of the bakelite strip.

up and listening. However, on various musical tones, all appear to register equally well. The mike-to-grid transformer described in a former *QST* is used in this rig."

A similar use for another type of watt-hour meter magnet was suggested independently by E. R. Patchen, of Lakeville, Conn. A sketch of a magnet of this type is shown in Fig. 5. These measure approximately 2 1/2 inches by 2 inches, and the bar is about 5/16-inch thick. The gap is too small to accommodate a ribbon of ordinary construction and must be widened to 1/4-inch by cutting off a small portion of the vertical arm. This may be done with carborundum wheel.

In making the microphone a number of the magnets are stacked to take care of the ribbon length used. They may be clamped together in any convenient fashion. It is necessary to check

the polarities, since the magnets are furnished in pairs for each watt-hour meter and the individual magnets of each pair are oppositely polarized. Mr. Patchen states that most power companies

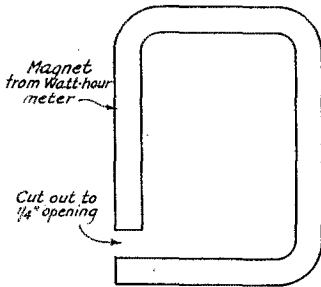

FIG. 5—A SECOND FORM OF WATT-HOUR METER MAGNET WHICH ALSO CAN BE USED IN THE CONSTRUCTION OF HOME-MADE VELOCITY MICROPHONES

have plenty of these magnets on hand, since they are frequently removed from meters brought in for checking and recalibration.

Portable Feeders

Fig. 6 indicates a convenient type of feeder for portable 56-mc. work suggested by H. P. Chandler, W3AKE, Springfield, Pa. The feeders—W3AKE uses No. 18 rubber-covered wire—are sewed into a piece of heavy composition cloth or canvas of the type used for roadster tops so that the spacing between the wires is two inches. This requires a three-inch wide piece of cloth,

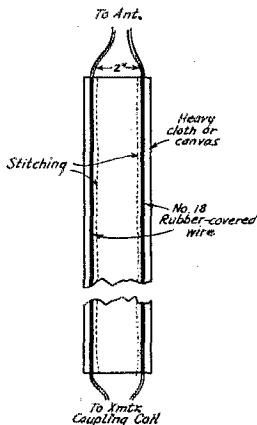

FIG. 6—PORTABLE FEEDERS FOR ULTRA-HIGH FREQUENCY WORK

The feed wires are sewed into a heavy cloth strip.

allowing a half-inch lap at each edge for stitching. The feeders may be any length desired depending upon the type of tuning employed. Those used by W3AKE are five feet long, and couple into a

Picard-type antenna. Odd multiples of four feet would be satisfactory for Zepp feeders if series tuning is to be used.

The advantages of this arrangement are obvious. The wires are kept uniformly spaced providing heavy canvas is used, require no insulating spacers, and do not twist in a breeze. If the wire is flexible the whole feeder system can be rolled up in a few seconds when it's time to move to a new location.

A "Marconi-Zepp"

Another method of operating an antenna on the next lower frequency band than its fundamental as a half-wave Hertz is suggested by George Underwood, W1GPE, of North Providence, R. I., in the letter below. The efficiency of the radiator should be as good, if not better, than with those arrangements which call upon Zepp feeders to do part of the radiating. With W1GPE's system the feeders continue to act as such—they do not radiate. Here is the story:

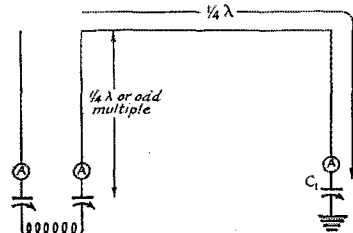

FIG. 7—GROUNDING THE FAR END OF A ZEPP ANTENNA PERMITS WORKING IT AS A QUARTER-WAVE MARCONI WITH END FEED

With this arrangement, used for operating an antenna on a lower frequency than its fundamental as a half-wave Hertz, the feeders do not radiate.

"For the past six months I have been experimenting with all sorts of antennas including one system I have used experimentally, but which I have not seen published. I'd call it a 'Marconi-Zepp.' The diagram is given in Fig. 7.

"With this system a Zepp designed for 80 can be used on 160, or one designed for 40 could be used on 80, etc. It has another desirable feature in that it can be tuned exactly, both feeders and flat-top. Possibly the best feature I found was that one could still use feeders with a Marconi antenna, and thus do away with feed-back difficulties usually accompanying radiating feeder systems when used on 'phone. Also neutralization remains FB, while it is often disturbed somewhat by a radiating feeder. Plenty of fellows with small backyards can use it to advantage, since the flat-top is only a quarter-wave affair.

"Accurate tuning of the flat-top is a little ticklish, and calls for a bit more care than with an ordinary Zepp. First, the system should be tuned at the transmitter end with condenser C_1

set about midway. Observe the current in each feeder. If they balance everything is OK. If not, the flat-top will call for some tuning, which is done with C_1 . C_1 should be fairly high in capacity to assure wide tolerance. About 350 μfd . is used here. Increasing or decreasing the capacity of C_1 will move the current loop on the feeders around, and when it is in the center of the coupling coil—where it should be—the feeder currents will balance, and cancellation will result.

"This antenna worked very well on 80 meters (the antenna being designed for 40) although I must add that I never have had the luck in DX with a Marconi that I've had with a half-wave strung up in the sky."

The idea can be carried a bit further by making the length of the antenna between the end of the feeder and the connection to C_1 equal to a half-wave for the next higher frequency band and installing a switch at C_1 so that the condenser and ground connection can be cut off when the antenna is to operate as a half-wave Zepp. The length of lead between C_1 and ground can be

"A" shows the connections to jacks 1, 2, 3 and 4; jacks 5, 6 and 7 are connected to the tank circuit and are always connected to plugs 5, 6 and 7 respectively.

The arrangement in "B" is for series tuning using a single condenser. "D" shows the connections for series tuning using a condenser in each feeder. "C" gives the wiring for parallel tuning.

The unused plugs can be omitted from the coils, but it would be advisable to drill all holes on each form so that plugs and connections can be changed should a change in feeder length make necessary a different method of tuning.

The expense of using this method instead of the usual arrangement with five jacks and plugs, is very small—only two extra jacks are required, together with one extra plug on the coils for those bands on which parallel tuning is used.

—Charles H. Robinson, W1GHS

Next Year's Model

(Continued from page 26)

As President is boarding train, telegram is handed him from Vice-President in attendance at RMA Convention, where it has been decided that in interests of stabilization of the industry no new home models be introduced during balance of year, but instead that vigorous campaign be launched to popularize automobile radio.

President goes fishing. Chief Engineer goes nuts.

Strays

We hear that at the South Bend hamfest John Reinartz, W1QP, won a prize which he offered at once to swap with the winner of the next one drawn. And the next thing pulled out of the hat was "How to Become a Radio Amateur"! Good work, John—all you need now is a License Manual!

Several requests have been received for separate copies of the frontispiece in May *QST* of Hiram P. Maxim. To supply this want we have had a supply printed on excellent coated paper with a special ink. When thoroughly dry these were shipped to New York and run through a pebbling machine. The final portrait is very effective and will be sent postpaid to any person desiring a copy. A charge of 10 cents (no stamps) is made to cover packing and mailing.

Copies of May *QST* are becoming increasingly scarce. Anyone desiring another copy of the Anniversary Number of *QST* may have same by addressing the Circulation Department and enclosing 25 cents.

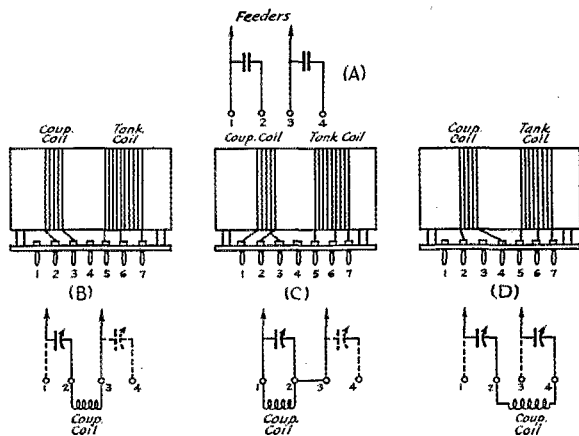

FIG. 8—A FEW EXTRA PLUGS AND JACKS ON THE FINAL AMPLIFIER COIL FORM WILL TAKE CARE OF SWITCHING THE FEEDER TUNING FROM SERIES TO PARALLEL WHEN CHANGING BANDS

anything convenient provided the total length of the system is not more than three-eighths of a wavelength, since the series condenser will shorten the electrical length.

Plugs and Jacks for Automatic Feeder Switching

Fig. 8 shows a set of diagrams for plug-in tank and antenna coils for a transmitter. The idea is to have automatic choice of series or parallel tuning as coils are changed. In building an amplifier for the Five-Band Exciter I wanted to make band changing in the amplifier as simple as that in the exciter, hence the brainstorm.



Amateur Radio STATIONS

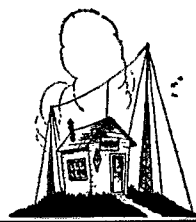

W2GOX, North Arlington, N. J.

THEY always come back"—even if a fellow's been out of the game a matter of decades instead of years. Back in 1908 John E. Preston built his first ham station. The next year found him a commercial operator, a profession which he



W2GOX

followed until 1914, when he dropped out of radio—for good, it seemed. But after twenty years of quiescence, the bug got in its fine work again, and now we find him back on the air as the owner of W2GOX, put into operation in February of this year. And from the looks of the photograph, no time has been wasted in getting together equipment of the most modern design.

The transmitter at the right in the photograph is a Collins 300-A, operated with inputs up to 600 watts. It uses a pair of 203-A's in the output stage. On the operating desk, at the left, is a National AGSX receiver, relay-rack mounted with power supply, loud-speaker and extra-coil panels. To its left is a Postal Booster, which adds two more stages of pre-selection to the receiver. A heterodyne frequency meter and control-switch are set into the opposite ends of the table below the operating surface.

In the short time that W2GOX has been on the air 45 countries have been worked, and WAC has been made four times over. The station works exclusively on 14 mc., using a 66-foot copper-tubing center-fed antenna. Steel cable run through the tubing keeps the radiator safely up in the air between two 60-foot poles. A nightly schedule

with K6IDK has been maintained for some time, W2GOX's signals usually being reported R8. Similar reports are regularly received from Europe and New Zealand.

W1DNF, Taunton, Mass.

THE number of amateurs that started out in the game with the classic pair of 45's in push-pull must be legion. W1DNF, owned by Joseph T. Plonka of Taunton, Mass., first went on the air with such an outfit, but has long since graduated to a rig considerably more complicated and effective.

The frame-mounted transmitter at the left in the photograph is a 'phone-c.w. set working on 14, 7 and 3.5 mc. It uses a 47 crystal oscillator, a buffer-doubler stage with a 46, a 10 second buffer-doubler, and a Western Electric 242-A final amplifier. Two plate supplies are used, one handling the first three tubes on the transmitter, the second the final amplifier. A power-pack supplies bias for the last stage. Inputs up to 300 watts are used on c.w.

The modulator is the unit at the left on the operating table. Two speech-amplifier stages

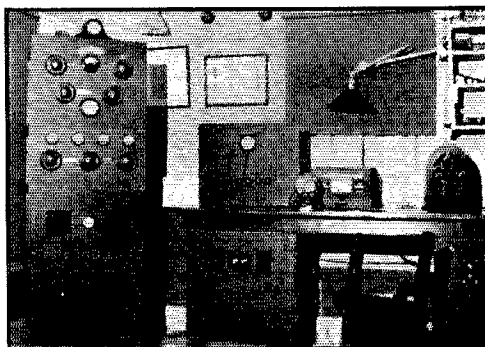

W1DNF

using 56's follow the Universal double-button microphone; the third speech stage has a pair of 45's in push-pull which in turn drive the Class-B modulator, a pair of 10's. The modulator operates at 750 volts, and gives sufficient audio power to modulate an input of 120 watts on the Class-C stage.

The receiver is an FBXA. W1DNF also has a 56-mc. outfit using the popular 37-37-38 super-regenerative receiver circuit and a pair of 71-A's for the transmitter. This equipment, however, does not appear in the photograph.

W6HOG, Glendale, Calif.

ANOTHER old-timer is Frank W. Allen, now W6HOG, but originally 9DCF, which call was issued to him in 1920. Allen has been active in either amateur or commercial radio during the intervening years, holding various calls during that time. W6HOG is maintained chiefly for experimental work and rag chewing.

The transmitter, at the left in the photograph, is a crystal job starting out with a 47 oscillator, followed by a 10 doubler, 203-A buffer, and a final amplifier using an 852. The final stage can be operated on either 7 or 14 mc., using the 203-A as a doubler for work on the latter band. The several crystals used are kept at constant temperature in a crystal oven. Keying is done in the primary of the power transformer of the final stage, a method which is effective in preventing clicks in a broadcast receiver in the same building, despite the fact that inputs up to 400 watts are used.

The receiver, which occupies the center of interest on the operating table, is a Hammarlund Comet Pro. To its right is an electron-coupled frequency-meter-monitor, arranged with a switch which transfers the phones to the monitor at the same instant the transmitter is turned on, thus

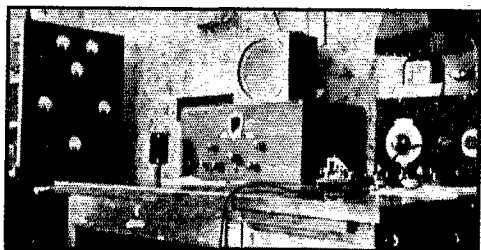

W6HOG

giving continuous monitoring of the transmitted signal. A three-tube regenerative receiver also is used in conjunction with the Pro, both being used with a doublet receiving antenna.

VE3EU, Toronto, Ontario

VE3EU, the station of Charles E. Mullaney, 626 Pape Ave., Toronto, Ont., is shown in the two accompanying photographs, one of which is a view of the operating table and the other of the transmitter.

The transmitter, which is housed in an angle-iron frame, consists of a 47 crystal oscillator, 10

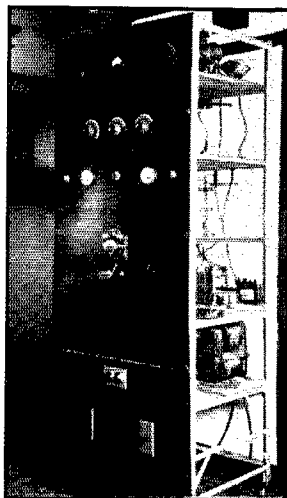
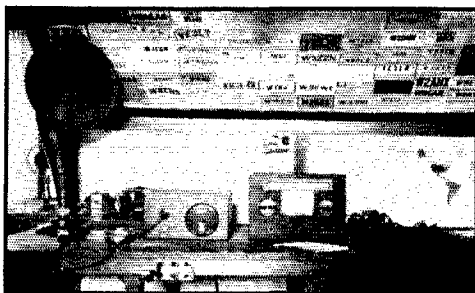

VE3EU

The receiving position is shown in the top photo and transmitter underneath.

buffer, and a 211-D final amplifier, the latter being run at 125 watts input. C.w. work is carried on chiefly in the 7000-kc. band, using a 66-foot current-fed Hertz antenna. Considerable 'phone work is done on 1750-kc., for which band a 133-foot Zepp antenna is used. The speech equipment includes a double-button microphone, a transformer-coupled amplifier using a 27 and 47, and a modulator consisting of two 211-E's in parallel, Class A.

A National FB-7 superhet is used for receiving. Next to it on the table is a combined frequency meter-monitor, using a 24-A electron-coupled oscillator and a 56 detector. A home-made power supply for the receiver is behind this unit.

Several countries in North and South America have been worked on 7-mc. c.w.

Correction

In Fig. 1, the circuit diagram of the two-tube receiver given on page 11, June *QST*, R_4 should be 2000 ohms; the 75-ohm center-tapped resistor is R_6 .

R_1 and R_2 in Fig. 1, page 41 of the June issue, should each be 25 megohms instead of .25 megohm. Fig. 1 is the diagram of the a.c. operated head amplifier.

• I. A. R. U. NEWS •

Devoted to the interests and activities of the
INTERNATIONAL AMATEUR RADIO UNION

President: H. P. MAXIM

Vice-President: C. H. STEWART

Secretary: K. B. WARNER

Headquarters Society: THE AMERICAN RADIO RELAY LEAGUE, West Hartford, Conn.

MEMBER SOCIETIES

American Radio Relay League
Associazione Radiotecnica Italiana
Canadian Section, A.R.R.L.
Československí Amatéri Vysílací
Deutscher Amateur Sende-und-Empfangs
Dienst
Experimenterende Danske Radioamatører
Irish Radio Transmitters Society
Liga Mexicana de Radio Experimentadores

Nederlandsche Vereeniging voor Internationaal Radioamateurisme
Nederlandsch-Indische Vereeniging voor Internationaal Radioamateurisme
New Zealand Association of Radio Transmitters
Norsk Radio Relé Liga
Polski Związek Krotkofalowcow
Radio Society of Great Britain
Rede dos Emissores Portugueses

Reseau Belge
Reseau des Emetteurs Français
South African Radio Relay League
Suomen Radioamatööritilito r.y.
Sveriges Sandareamatörer
Unión de Radioemisores Españoles
Union Schweiz Kurzwellen Amateur
Wireless Institute of Australia

The Amateur Regulations of the World

THE most significant occurrence in international amateur radio during the past year has been the increase in the privileges enjoyed by the amateurs of so many nations, particularly in Europe. Where a year ago only a relatively small percentage of the treaty bands were actually available to amateur occupancy in many of these countries, at the time of writing the majority of the major nations of the earth now permit the use by their amateurs of practically the entire territory reserved for them by the Madrid treaty.

To emphasize this point, and to make generally available information of value to every internationally-minded amateur, this department will this month be devoted to a summary of the existing amateur regulations in fourteen representative nations. In addition to the specific details it contains concerning individual countries, this report can be regarded as representing an accurate cross-section of governmental opinion concerning amateur radio throughout the world.

First, Belgium. Until the first of this year amateur radio in Belgium was practically without official recognition, as a result of a drastic change in the amateur licensing situation following upon the restrictive recommendations of The Hague C.C.I.R. meeting in 1929. To-day, the following bands are generally permitted: 3518-3553, 7035-7264, 14,070-14,328, 28,140-29, 850, 56, 280 and above. Telephony is permitted on all bands. Special authorization for operation on 1750 kc. can be obtained. Operator licenses only are required; there is an adequate examination; the fee for a combined operator-station license is 75 francs for 10 watts, 150 fr. for 50 watts. The hours of working are restricted as follows: Week

days, 0000-1100, 1400-1600, 2300-2400, local time. Sundays, 0000-1100, 2300-2400. Pure d.c. is required; no frequency modulation with 'phone. Automatic sending, but no automatic reception, is permitted. No relaying of messages is tolerated, whether of a private or scientific nature. There are 370 active stations.

In Czechoslovakia the bands are 3500-3600, 7000-7300, 14,000-14,400, and 28,000-30,000 kc. The 1750-kc. band is unqualifiedly denied. The fee for the operator's license is 200.-Kč. Station licenses are free. A maximum input of 50 watts is specified. No third-party traffic is permitted. There are 105 licensed transmitters, according to the C.A.V.

In Germany all of the higher frequency bands are available to treaty limits; the 3500-kc. band extends only to 3600 kc., and 1715 kc. is denied. No amateur telephony is permitted. The combined operator-station license is issued by the German Reichspost, after examination of the applicant by the D.A.S.D., the fee being RM 2.00 per month. Maximum input is 50 watts; pure d.c. supply. Tone modulation is permitted by the government, but banned by the D.A.S.D. No third-party traffic is permitted. Latest available reports indicate that there are about 300 licensed stations.

In Great Britain, general operation is permitted on 1730-1985, 7025-7275, and 14,030-14,370 kc. R.S.G.B. stations can operate from 3520 to 3730 kc. On special application, the bands 28,050-29,950 and 56,070-59,930 are available. The 3500-kc. region is available for daily use only in the months from October to May; during the remaining four months operation is restricted to the period 1500 G.T. Saturdays to 2400 G.T. Sundays. Operators must pass

an examination; the fee is 5/-. Power is unlimited, within treaty limits, upon individual authorization; the normal license is for 10 watts, fee £1 per annum plus 10/- initial registration. Increases of power irrespective of amount cost an extra £1 per year, plus 10/- for initial registration. R.S.G.B. recommends applicants for increased power; approximately 40% of its 750 licensed members are licensed to use more than 10 watts. A year's experience is ordinarily required before increase; the increase is then to 50 watts. Pure d.c. must be used. No third-party traffic is permitted.

The Irish Free State permits general operation in the 1750-, 7000-, and 14,000-kc. treaty bands; operation in the remaining bands is permissible upon special application. Telephony is permitted in all bands. The operator's license fee is 5/-, the station license fee £3 for the first year, £1 thereafter. The maximum power is 10 watts, although special permission may be obtained for higher power. No third-party traffic is permitted.

Italy is the one major power which does not now permit amateur radio. It is interesting from the political standpoint, in that this intolerant attitude seems to derive from the Fascist government, while in Germany the Nazi's have been notably liberal toward amateur radio, the attitudes in both countries being in direct contrast to that exhibited by previous régimes. There is some hope that the situation in Italy, too, will be liberalized some time in the future. Meanwhile, one or two "pirates" continue active, without apparent molestation.

The Mexican government permits all the treaty bands, as in the U. S. Emissions must be c.w.; the maximum power is 1 kw. There are no fees. Third-party traffic is at present limited to contact with expeditions; this provision will, it is expected, be liberalized shortly. There are over 150 licensed transmitters.

In New Zealand, beginners start out on the 1.75- and 3.5-mc. bands, graduating after six months to the higher frequency bands upon special permission from the authorities. Telephony is permitted on all bands except 7 and 14 mc. Outputs of 100 watts can be used. The operator's license fee is 5/-, station license fee £1/10. There are 775 licensed transmitters. Those who have analyzed these regulations thus far will have noted that here, as in America, the treaty provision for sharing the two low frequency bands does not result in restricting their use by amateurs, as is almost universally the case in Europe.

In Norway, all bands are permitted except the 1750-kc. band, with the reservation of buffer territory at each end of the bands as follows: 3.5 mc., 40 kc.; 7 mc., 50 kc.; 14 mc., 60 kc.; 28 mc., 100 kc.; 56 mc., 200 kc. Telephony is permitted on all bands. D.c. plate supply, 50 watts maximum input (interpreted as 20 watts in the antenna). The operator's and station

license is combined, the fee being 30 kr. per annum; licenses are issued those who successfully pass an examination conducted by the N.R.R.L. Third-party traffic is limited to "totally unimportant greetings." The N.R.R.L. claims 76 licensed members.

In Poland, buffer widths are provided on all bands, as follows: 1715-1800, 3535-3565, 7050-7245, 14,090-14,310, 28,160-29,830, and 56,300-59,680 kc. License examinations are conducted by the P.Z.K.; the operator's license fee is 5 zloty annually, as is the station license fee. The maximum power input is 50 watts. Poland is the one European country in which third-party traffic is permitted, a recent grant and one for which the P.Z.K. deserves great commendation. There are more than 200 licensed stations.

Portuguese regulations are very liberal, for Europe, all bands being permitted without restriction. Three hundred watts input is permitted, but no telephony. The licenses are granted in connection with the R.E.P., the fee for a station license being 25\$00 for the examination, and 10\$00 thereafter monthly. There are 153 licensed stations, according to the R.E.P.

South Africa also permits all the Madrid bands to be used by her amateurs, with no restrictions, telephony being allowed on all bands. The operator's examination consists of a code test; the fee is 5/-. No station license fee is required. The S.A.R.R.L. assists the government in passing upon applicants. The maximum power input is 50 watts. Message traffic is limited to S.A.R.R.L. business traffic transmitted by member-stations; no general third-party traffic is permitted. Of the League's membership, 157 are licensed.

The Spanish amateur bands are as follows: 1735-1985, 3520-3730, 7000-7300, 14,000-14,400, 28,000-30,000, 56,000 kc. and higher. Special authorization is required for operation in the 1.75- and 3.5-mc. bands, but this is merely a formality designed to inform the government as to the number of amateurs desiring to use these bands. Spain was one of the few countries which opposed the "shared" classification of these bands at the Madrid Conference. Some 'phone is used in the 7-mc. band, but most of this operation is on 3.5 and 14 mc. Combined operator and station licenses are issued, upon separate examinations, the fees being 20 Pesetas initially and 2 Pts. per watt per year. The power maximum is 50 watts, but there are exceptions. Pure d.c. and stable telephony. Third-party traffic is prohibited. Further liberalization of the general amateur regulations is expected by the U.R.E. There are 307 licensed members.

In Switzerland, a special license is required for 1.75 mc. The other bands are as in the treaty, with the exception of the 3.5-mc. band, which extends from 3500 to 3700. Telephony is permitted in all bands. The operator's license fee is

(Continued on page 80)

THE COMMUNICATIONS DEPARTMENT



F. E. Handy, Communications Manager
E. L. Battey, Assistant Communications Manager



THE season for long DX days on 14 mc., for vacations, and portable-mobile work is at its peak. Rebuilding plans take some sets off the air; u.h.f. fun puts new transmitters in operation at home and afield.

Effective October 1, 1934, an *International 28-mc. Contest*, to be in progress for one year, concluding at midnight September 30, 1935, is open to all hams under the sponsorship of the R.S.G.B. In addition to an R.S.G.B. International Trophy and certificates to the leading ten stations wherever they prove to be, the A.R.R.L. will make an award to the highest United States or Canadian operator-experimenter. This will be inscribed FOR 28-MC. ACHIEVEMENT, OCTOBER 1, 1934-SEPTEMBER 30, 1935.

The League's award will be a bronze charm, engraved as above, and with the call of the winner. One point will be scored for each completed 100 miles of contact. Decision between W/VE competitors will be based on weighted credits: (1) The number of weekly reports to A.R.R.L. on 28-mc. work, 25%; (2) description of equipment, and development work reported on same, 25%; (3) the number of points scored (monthly contacts with the same stations will be permitted to count), 50%. W/VE entries must be received at A.R.R.L. on or before October 15, 1935. Full rules will appear next month. The 28-mc. band has been "hot" with dozens of DX contacts reported during each month, starting with March this year. Get new 28-mc. sets built. Fix the 14-mc. tanks to work on 28 mc. Start testing equipment now. Report your results each week to A.R.R.L., and submit scores and log to both A.R.R.L. and R.S.G.B. at the end of the contest to be eligible for all awards.

'Phone Work With India

W9HQH, Chicago, with 50 watts input on 14-mc. 'phone, worked VU2CP, Calcutta, India, at 12:55 p.m. C.S.T., June 3rd. W9HQH advises that VU2CP has a p.d.c. note on 14,150 kc. and wishes to contact as many W and VE 'phones as possible. W9ELA Minneapolis, Minn., also worked this VU on June 9th at 8:05 p.m. Central Time.

COMING MEETINGS

Third Annual Hamfest of the WIMU Radio Association, August 4th, 5th and 6th, will be held at Jenny Lake in Teton National Park, Wyoming. WIMU includes Wyoming, Idaho, Montana and Utah, but all hams are invited. For complete details write or QSO W7BNU, W7AEC, W6DWH, W9DBW, W9JES, W7AMA or W9ESA.

Central Illinois Radio Club Hamfest, August 5th, announced in July *QST* to be held at Municipal Park, Bloomington, Ill., will be held at the Maplewood Country Club, that city, instead.

Northern Illinois State Hamfest, August 12th, auspices Ogle County Radio Traffic Association, to be held at Pines State Park, Oregon, Ill. Registration 25¢. Bring 5- and 10-meter portables. Coffee and ice cream furnished; bring basket lunch. And don't forget the YLs and XYLs! Good program promised.

Starved Rock Radio Club Hamfest, August 19th, Starved Rock State Park, Spring Valley, Ill. Registration, 50¢, includes eats, prizes and entertainment.

Third Annual Hamfest Island Radio Club, Bar Harbor, Maine, August 25th and 26th, Saturday and Sunday. Program will include sporting events, prize competition, code contests, and a big feed Sunday, as well as visits to local ham shacks, a points of interest, etc.

A Ham's "If"

(With apologies to Kipling)
By PHIL McCrum,* WICRP

If you can keep your sked when all about you
Are losing theirs and blaming it on you,
If you can trust your wave when all men doubt you,
But make allowance for their doubting too;
If you can send and not be tired by sending,
Or asked to QRS, don't deal in speed,
If some one on your traffic is depending
And you leave him with a message QSP'd:
If you can handle traffic and keep it on the go,
If you can work DX and not make that your aim,
If you can work with ops both fast and slow
And treat those two co-workers just the same;
If you can bear to hear the truth you've spoken
Twisted by lids who know not all the rules,
Or watch the parts you gave your coin for, broken
And stoop and build them up with worn-out tools:
If you can keep your two-ten running
And show a two-O-four who is the boss,
Or lose and still keep things a humming
And never dit a dah about your loss;
If you can force your key and tubes and meter
To serve their turn long after they are gone,
And so hold on when they begin to peter,
But keep the will which says to them, "Hold on!"
If you can pound the brass and keep your virtue,
Or talk with 'phone, nor lose the common touch;
If neither speed nor lids can hurt you,
If all hams count with you, but none too much;
If you can fill each operating minute
With sixty seconds worth of distance run,
Yours is the air and everything that's in it,
And what is more—you'll be a ham, my son!

* A.R.R.L. Route Manager, 61 Madeline St., Portland, Me.

A New System of Signal Reports

AT present, to get a complete report on our signals, we must resort to a mixture of plain language questions, QSA, R, and T reports, and international abbreviations. It is believed that a system which would give all this information quickly and concisely would be readily adopted by amateurs. The "T" system is a step in the right direction, but it attempts to combine into a single scale such widely different characteristics as those of frequency (steadiness, etc.) and modulation (tone). Some time ago "The Keywagger" printed an explanation of the "Frame" reports used by some commercial stations. This has been taken as a basis and has been condensed and modified somewhat to make it more applicable to amateur use.

There are four principal characteristics of signals that we are interested in. First, those of frequency variation, such as swinging, chirping, etc. Second, those of signal strength. Third, those of variations in amplitude (fading). Fourth, those of modulation, or tone. In the system proposed here each of these characteristics is designated by a scale running from 1 (least desirable signal) up to 9 (perfect signal). In the order given, the scales are designated by the letters "F," "R," "A," and "M." While no exact definitions can be given, the following is an example of an amplitude, or "A" scale:

(1) Fading completely out, impossible to copy. (2) Fading almost out, very difficult to copy. (3) Fading badly, difficult to copy. (4) Fading badly, but copyable. (5) Moderate fading. (6) Some fading. (7) Slight fading at times. (8) Slight traces of fading. (9) Absolutely no fading.

As a further example, our modulation, or "M" scale might run something like this:

(1) A.C. (raw). (2) A.C., but better than 1. (3) R.A.C., self-rectified, or poor R.A.C. (4) Good R.A.C. (5) Slightly musical, R.A.C. with small smoothing filter. (6) N.D.C., musical, but rough. (7) Good note, very N.D.C. (8) D.C., excellent note with very slight modulation. (9) Absolutely pure D.C.

The system would be used as follows:

A station desiring a report would send "FRAM?". The report might come back something like this: "FRAM 8578." And that tells the whole story. Why not give it a try? Yours for "FRAM 9999."

—Lt. D. C. Redgrave, KA1NA.

Making Signals Effective

Nothing is more aggravating or wasteful of time than to listen to 75 or more CQs before a fellow signs his call. Few hams realize that more than 50% of their listeners pass them up due to such procedure. Habitual long CQ-ers get poor results for the time spent! Let us all put in our call every three or four CQ's and make our stations more effective!

Another thorn in the side is the improper use of dit-dah-dit at the opening of all comebacks. The procedure is entirely out of order when followed by "pse rpt msg" or the equivalent. Use the "R" only when all the transmission is OK. In other cases use the time in stating clearly and concisely just what portions require fills.

One of the bets many hams overlook is the correct use of Q Code. Use more Q sigs—but use them properly. Look up each signal as used as long as this is necessary to familiarize yourself with the meanings, and you will become known as a good operator. "QSL NR 1" does not refer to "needing cards for the shack"—it requests acknowledgment of message number one. Look it up and remember it!

—Kenneth Isbell, W6BOQ-W6AMR.

Echoes of the Sweepstakes

W9BWF votes for "most consistent signals": W7EK (14 mc.), W4CA (7 mc.), W9BWJ (3.5 mc.). W9DGS got a great kick out of being W9UM's 65th Sec-

tion. W9ERY, with his station in a gas station had plenty of QRM from the curious public. W9DFY was well guarded, being located in the local police department. W3CL and the Philadelphia gang have labeled punk signals "Sunday Driver" signals! W1BEF and W9IYA had snappy QSLs made up special for the contest—W1BEF's showed a fellow sweeping the country with an SS broom. W6AF found W9GDH and W4CA among the most consistent signals. W2CUQ, an old-timer dating back 11 or 12 years, found SS QSOs better and longer than the average every-day contact. W9HQH was on the air an average of 3¼ hours per day, working 94 stations in 48 sections. W9EF used 3.5-mc. band for the first time since 1924 and says, "It was the best band." 74.5% of W7AAT's contacts were on 3.5 mc., while 7 mc. claimed 25.5%. W6FFP worked New Hampshire (three stations) for the first time after trying for three years. Who didn't get a laugh out of the texts of many of the SS messages? Mae West and her, "Why doncha cum up sum time" came in for its share. In spite of the many inquiries as to the whereabouts of "Annie" she has not yet been located! W6HRN lost nothing but a 511-D and plenty of sleep. Only 19 of the 174 W's worked at W4DW had two-letter calls. Which reminds us, W9PDC is on the air! W8APQ with his little '45 aimed at 50 sections, 15,000 points and made it with some to spare. The set-backs experienced by W2SN during the contest would fill a book—ask him about them! The W1BWJ operators found 3.5 mc. the best place to get points, and 7 mc. the best band to get new sections. Eight operators at Stevens Institute of Technology, Hoboken, N. J., kept W2BSC, Stevens Radio Club station, on the air 21 hours per day running up a station total of 46,805 points, a respectable showing for any number of operators! Each operator stood 3-hour shifts. Three transmitters were used, one on 3540-kc. with 250 watts input, a 7 and 14 mc. rig with 100 watts input, and a flea power 1.75 mc. rig. W9AUH says "Anyone doubling my score is a gentleman and a scholar and is welcome to it," but aside from this, he'd like to be shown! The most unusual message at W3DNC was one where he was advised that a brother SSer's cow had just had a calf—accordingly W3DNC sent his congratulations to the cow. W4AAQ says 24 different stations were worked in Illinois, more than in any other section. Short snappy CQ SS calls are effective—324 such calls at W4AAQ netted 212 QSOs, a percentage of 65. All the non-participants had a different guess as to the meaning of "SS"—sirloin steaks, sweet sugar, shaving soap, sharp shooter, single signal and all the rest. Perhaps the youngest SS contestant was W8JTP, 12 years old. W9EYH was not handicapped by an indoor antenna in the attic (witness his 22,950 total!). W7EK and W8DSQ, SS participants, are members of the well known Chair Warmers Club. W9UM worked every Section heard. W1COI's "average miles per watt" for the contest was 222.

Naval Reserve Notes

The approximately thirty stations comprising the Naval Reserve national network are all authorized to use 4045 and 3475 kcs. This "net" operates regularly except in the summer season. The most recent drill on June 7th on 4045 kcs. was an outstanding example of smooth, snappy, correct, precision operating with proper NCR procedure. The control stations in this net are identified as follows: NDA, Boston, Mass.; NDR, Portland, Me.; NDF, Rochester, N. Y.; NDB, N. Y. C.; NDM, Philadelphia, Pa.; NDC, Pittsburgh, Pa.; NDE, Baltimore, Md.; NDK, Norfolk, Va.; NDJ, Atlanta, Ga.; NEF, Charlotte, N. C.; NDL, Orlando, Fla.; NDU, Jacksonville, Fla.; NDD, Pensacola, Fla.; NDZ, Dallas, Tex.; NDS, Chicago, Ill.; NDP, Kansas City, Mo.; NEG, Cincinnati, O.; NDV, Los Angeles, Cal.; NDT, San Diego, Cal.; NDH, San Francisco, Cal.; NDO, Salt Lake City, Utah; NDQ, Seattle, Wash.; NDI, Portland, Ore.; NIC, Honolulu, T. H.; NDG, Balboa, C. Z.; NEQ, Cristobal C. Z.; NEC, San Juan, P. R.; NEJ, Mayaguez, P. R.; NED, Washington, D. C.; NDN, Washington, D. C.

Third Naval District: Effective July 10, 1934, a point to point traffic net has been authorized for all stations in this district to encourage and facilitate inter-sectional message handling using NCR procedure between unit stations. There are five Sections represented in the District. *The net will function each Tuesday*, all NCR-amateurs using their regular Section frequencies in the 3500-ke. end of the band. Unit stations work with the Section Guard 7.00 to 7.30 p.m. EST. Then while unit stations are silent the guard stations in the several sections and the District Control Station, NDF or NDB, all exchange messages for the next 50 minutes, each Section being allotted 10 minutes for work with each other Section. After 8:20 p.m. EST the Section Guard clears the traffic exchanged to unit stations, thus enabling all NCR hams in the District to send messages to each other. This supplements but does not take the place of the Friday drills.

Requests for information on the Naval Communication Reserve should be addressed to Lt.-Comdr. Wm. J. Lee, Office of Chief of Naval Operations, Navy Department, Washington, D. C.

Briefs

W5CLP has found that an Agfa "Snapfolio," distributed by dealers in Agfa films, makes a convenient carrying case for the new amateur licenses. He says these "Snapfolios" are furnished free by most dealers.

The following contribution by Mr. R. H. Cunningham, VK3ML, wins the C.D. article contest prize for this month. Your articles on any phase of amateur communication activity are likewise solicited and may win you a bound Handbook, six logs, or equivalent credit applied toward other A.R.R.L. supplies. Let us have your article, and mark it "for the C.D. Contest," please.

—F. E. H.

What Is Good Operating?

R. H. Cunningham, VK3ML*

ONE continuously reads in radio magazines throughout the world of operating—wise and otherwise. Good operating is an art. As with any art, there is always a foundation to start with; once this is found, then, we have a definite basis to work from. Such articles as I have been studying lately seem to suggest either cures or remedies for bad operating or hint at better practices. The rock-bottom, so to speak, has been missed.

I venture to offer what I consider to be the *main* essential of good operating, and that is a *good fist*. I maintain that good operating, whatever the procedure may be, is governed by this one factor. Volumes of hints and advice are useless to any man who has neglected his sending.

A good fist is developed by paying careful attention to the formation of the characters composing each letter. It requires a mechanical rhythm-like sense—one that will instinctively tell whether the timing is perfect or not. This comes with practice, and by self-examination! Examine your sending. See whether there is room for one dot between the characters forming a letter. Note if three dots could be inserted between each letter; also whether you leave room for five dots between each word at any speed. As in drill exercises, one's sending habits are formed by practice. After a period it is no longer necessary to time the movements so carefully. One unconsciously develops rhythm in sending.

A good sender is invariably a good operator. He has taken care to develop a good fist, and he will likewise take the same trouble to carefully study the other factors that govern good operating procedure. How many operators qualify in the following essentials? (1) Possess a thorough knowledge of standard operating procedure and avoid departure therefrom. (2) Have a complete understanding of operating signals—"Q" Code and recognized amateur abbreviations. (3) Adhere strictly to customary practices such as (a) combing the band after VA, (b) calling CQ in the correct manner followed by K, (c) making all calls of reasonable length interrupted by listening periods.

A good fist is coincident with good operating practices. One does not go without the other.

Personally, I think that teaching and practising Morse on a buzzer or audio oscillator is a poor method compared to a sounder. A sounder possesses the advantage of indicating the start and finish of a character and, consequently, shows up the formation more distinctly. This instrument can be used to monitor one's sending on the air, too.

Many of us would feel very self-conscious about our sending if "our best friends" were to tell us what it was like. However, there is no reason why one should feel disgraced. We are all apt to develop peculiar little habits in the formation of letters and unless "put wise" will go on practicing them forever. I suggest that pleas for better operating be supplanted by cries for better sending.

1. To pattern one's sending by a really proficient operator, or to emulate tape transmissions as a standard of perfection, will also help.

* 1 Dalney St., Malvern S. E. 4, Victoria, Australia.

BRASS POUNDERS' LEAGUE

(May 16th—June 15th)

Call	Orig.	Del.	Ret.	Total
W2EKM	70	72	1652	1824
W3WT	251	47	1498	1796
W6ETL	206	304	1144	1654
W2BCX	160	196	1178	1534
KAINA	196	165	1132	1493
W6ALU	117	294	596	1007
W9ESA	53	138	762	953
W3OK	235	94	405	734
W9GJQ	61	44	626	731
W6FRN	40	19	653	712
OM2AA	237	161	298	696
W6BMC	11	10	682	693
W6HZZ	78	122	430	630
W6GXM	176	302	150	628
W8JTT	80	57	480	617
W5CEZ	80	69	450	599
W9HKK	18	25	552	595
W2EYQ	94	32	416	592
W8DSS	72	51	468	591
W2ENZ	64	103	404	571
KAI CB	196	143	198	537
W1MK	55	59	392	536
W8EIK	6	11	510	527
W3BWT	120	64	333	517
W2BZZ	25	36	452	513
W7DRY	45	67	400	512
W9LEZ	32	42	438	512
W5BMI	26	31	453	510
W8FCS	39	31	389	509
W9DOU	51	117	338	506
W7DBR	8	11	482	501

MORE-THAN-ONE-OPERATOR STATIONS

W3OXL	197	431	3711	4339
K6EWQ	685	371	2598	3654
W6ZZ	787	1080	704	2571
KAIHR	593	394	754	1741
W5OW	115	86	850	1051

These stations "make" the B.P.L. with totals of 500 or over. Many "rate" extra credit for one hundred or more deliveries. The following one-operator stations make the B.P.L. for delivering 100 or more messages; the number of deliveries is as follows: Deliveries count!

W2ELK, 204	KAI FS, 137	W1AMG, 109
W2ELK*, 178	K7PQ, 122	W6ERK, 106
W6IG, 172	KAI BE, 121	W6EXL-K5AF, 102
W3BND, 171	W1FFL, 111	W8FTW, 102

A total of 500 or more, or just 100 or more deliveries will put you in line for a place in the B.P.L.

* April-May.

Washita Valley Flood

About 2:30 a.m., April 4, 1934, the Washita River went on a rampage, sweeping away everything in its path. Seventeen persons lost their lives. Property damage ran into the millions. Communication was cut off from Hammon, Leedy, Butler and Quartermaster.

Word reached the writers, W5ACI and W5BBE, via broadcast station KASA, Elk City, Oklahoma (25 miles south of the flooded district), that the entire town of Hammon was washed away. We immediately constructed a portable battery-powered transmitter, and started for the stricken area.

Arriving at Hammon, we found that nine miles below the town people were in trees, on drifts and on house tops awaiting help. We went at once to the scene. We attempted communication from a hurried set-up, but did not meet with much success due to the poor antenna facilities. Nightfall found us on the river banks helping with the rescue work. Several boats were capsized, putting the crew in trees. Among those unfortunate enough to be capsized was W5ATO, Granite, Okla., whom we found roosting in a tree.

By 5:00 a.m., April 5th, most of the rescue work was completed. We returned to Hammon and got the rig working on the 1.7-mc. band. We were located in the American Legion Hall. We advised relief workers that we could forward communications by radio for their needs and any news they might wish to send. Direct communication with KASA was established at 7:15 a.m. We handled emergency traffic for relief headquarters, calls for relief searchers, information relative to food and clothing needed, etc. Altogether we handled 150 messages the first day. Things having quieted down by night, we shut down to make up some of the 42 hours of lost sleep.

At 4:00 a.m., April 6th, we were back on the job. We made an attempt to contact amateurs, since KASA would not be on until 6:30. W5CFN, W5GB, W5PB, and W5LZ reported that they were standing by for traffic. W5BKN at Leedy, in the flooded area, got on the air about 8:30 a.m. and handled considerable emergency traffic. By the afternoon of the 6th, power and telephone lines had been repaired, so we dismantled and started for home.

—W5ACI and W5BBH

WORLD'S FAIR RADIO AMATEUR EXHIBIT

Visitors to the Radio Amateur Exhibit booth at the World's Fair go home with a rather novel memoir of their visit—a "Souvenir Radiogram." At an old-time Spark station the visitor may file a message; this message is sent by radio (oscillator without antenna) to the "modern ham shack" at the other end of the room. Here it is received, typed out on a special "Souvenir Radiogram" blank and presented to the visitor as he reaches the "modern shack." The reverse side of the blank contains a brief story of amateur radio.

The W9USA transmitter at the Court of the Hall of Science is getting out very well, as is the transmitter at the Exhibit. Every operator who comes to the Exhibit to operate receives a card certifying that he operated W9USA. *But please remember:* before any operator is permitted to work the station, he must present his operator's license. No one is permitted to operate W9USA without his operator's license. Bring your license when you visit W9USA!

Briefs

"Some operators have the habit of trying to use a bug at speeds much faster than they are capable of with the resultant hash we are all too familiar with. The habit is a bad one. It may impress a beginner or two, but is a pain in the neck to every decent operator. It is spoiling many a good fist."—W9DXY.

The San Isabel Radio Club, Pueblo, Colo., announces: "For traffic to or through Pueblo, Colorado call 'CQ

Pueblo' between 8:30 and 9:00 p.m. M.S.T. Monday on 3.5 mc., Wednesday on 7 mc., Friday on 3.5 mc."

Regarding Mr. K. G. Morrison's article on Radiophone Traffic Handling (see page 51, June 1934 *QST*):

The commercial radiophone net referred to is owned by Libby, McNeill and Libby, Bristol Bay, Alaska. Six salmon cannery stations in a radius of 50 miles work the control station at Libbyville, and also connect with a score of 5-watt installations on gas boats and tally scows. The stations: Libbyville, KIAM; Nushagak, KNO; Ekuk, KMG; Eggegik, KMF; Koggiung, KVV; Lockanok, KML. All transmitters are crystal-controlled on 3184 kc., and KIAM distributes traffic (arriving via Washington-Alaska Army net long wave c.w.) to the other stations by radiophone, since the other net stations have no other means of communication.

The Birmingham (Ala.) Amateur Radio Club will attempt to gather information on the progress of the National Balloon Race starting at Birmingham, July 28th. A continuous watch will be maintained by Birmingham stations on 14, 7 and 3.5 mc. for reception of reports. All amateurs are requested to be on the lookout and report to any Birmingham station.

W1AMG reports that W2AV, Brooklyn, N. Y., schedules the Schooner *Morrisey* daily. Any communications for the *Morrisey* may be thus routed.

W1BAC and WIACD are located for the summer at the Lonesome Lake Appalachian Mountain Club Hut in the White Mountains, New Hampshire, as hutmaster and assistant. 3.5-mc. c.w. will be used daily and tests will be conducted with 56-mc. 'phone from the surrounding mountains. They are anxious to receive reports and to communicate with 56-mc. hams on Sundays.

The Federation of Radio Clubs, Southern California, will conduct 28-mc. tests each Saturday and Sunday during August. Reports will be appreciated.

Famous Saying, by W1QV at New England Division Convention, 1934: "After all, it's only a hobby!" (This is recommended for use after being bitten by mosquitoes on field day excursions, after arguments with BCLs, after blowing tubes, after counting 105 CQ's in a row, after a "CUL 73" QSO, etc.)

From W9BLK-HPU: "I was QSO via telephone with W9ABJ the other day, and he told me that a ham in Tennessee gave him a report on his signals of '500 cycle p.d.c.' Quite a report!"

On Adjusting Bug Keys

W9GY, J. H. Platz, comments as follows on this subject: "Have discussed keying adjustment with several ex-commercial operators, and the universal sentiment was that bugs should *not* be adjusted to dot at 50% of the closed circuit current. That 'dot' is perfect for wire lines, but not for radio QRM and QRN. Many commercials with machine sending also use machine copying, which is a different matter, and they do not work through the QRM that the ham does! I have been using a bug for several years *adjusted to go closed after 8 or 9 dots*, and have had many compliments on my keying. Can go up to '30 per' through QRM with a good opr., but let me lighten the dots to 'machine type' and repeats are required. You can send as fast and more readably with a 'heavy' bug than with a 50% adjustment." General information on the proper adjustment of bugs appeared in *QST* for February, page 18.

CQ "TFC"

A familiar call to all 3500-3900 kc. operators is CQ TFC. It is an excellent call to use when one wants traffic to deliver or relay. Many new hams have misinterpreted this call, believing it an indication a station has traffic to move, when its use normally indicates quite the contrary. When you hear a CQ TFC it is an expression of the operator's desire to help you, and take your traffic. CQ TFC is a good general call to use whenever you wish to handle traffic in general operation. It moves traffic on and off trunk lines, and makes many profitable contacts possible between scheduled periods.

The Use of "ORS" After a Call

One also hears more and more after a "ORS" after calls these days. The "ORS" added after a "sine" is the mark of a reliable operator. It helps other amateurs to know an experienced man is *on the air*, and ready to help in relaying traffic or making deliveries if they will but give him a call. "ORS" are known widely for their good signals, fine operating, courtesy, and general efficiency and readiness for any communicating job. "ORS" sent after a sign-off is hammy and filled with fraternal spirit, in addition to its practical use in establishing "identity." It aids general traffic movement, too. If you have traffic, try to give it to a station that signs "ORS." A postal will bring any League member information on becoming an Official Relay Station appointee.

NEW MEMBERS—A-1 OPERATOR CLUB

C.W.: W1AJ ATO BMW BNC BVR DUK EBM FH SB W3BAS BG BJX VH ZC W3CLV CXL (YX) DFK DXG HC W4ALK JR MI W5AJF ALZ ANU AQ AVF BKH BQZ MN W6AJP BLP BPM CRF DKN EGS ELU EXH LM PQ (CV) W7ASN BFM DUE KO W8BWL BWY CAT CVS DHU DVC DWB EPY EUY GBF GLX GRZ IOR JAK JES (Paul) JTT OB SS UW YA (NOR) W9AIO BBS CSI EKY GJQ HJC HSN HTU HUM IFZ IOL KJY KKT MZD PDE TA VE1EP 3JI 5HR K4KD Foreign: D4UAN EI8B G5QY J2GX NY1AB (Van & Mac) OK1AW VK5HG ZL1FT 4A1 4A0

'PHONE: W3BUY NK W8APN KIR W9CPD VE3JI

This is a supplement to the complete roster of A-1 Operators which appeared in May *QST*, page 88. Complete details on the A.R.R.L. A-1 Operator Club will be found on page 64, July *QST*, under the heading "What is an A-1 Operator?" Every active amateur should strive to "rate" membership in this group of recognized "A-1" operators.

Briefs

W2GWE, Woodmere, L. I., reports what he believes to be the first W2-KA QSO—KA1CM and W2GWE were in contact at 7:25 a.m. Eastern Time, on March 12th, on 7 mc. On April 3rd, at 4:30 p.m. E.T., W2GWE worked FE3AOG, reported to be in French Soudan, French Equatorial Africa.

Radio amateurs of Fort William and Port Arthur, Ontario, and surrounding territory held the first get-together ever staged in that part of Ontario. The meeting place was the Y.M.C.A., Fort William, the date was April 17th. Following a big feed at which about 25 hungry hams did their stuff (and that's a lot of hams in that neck of the woods), P. J. O'Shea, VE3FW, took the chair to handle the organizing of a Radio Amateurs' Association. He was unanimously chosen president. Several interesting talks, a "grab bag," and almost limitless rag chewing made the affair enjoyable for all. Every licensed amateur and would-be amateur who could not be present at this first meeting of the new Association but who would be interested in further details, is invited to write Bruce Grant, Secretary-Treasurer, care of P. J. O'Shea, 227 N. Norah Street, Ft. William, Ontario.

On January 27th a Mrs. Charles Fredricks of Los Angeles filed a message at W6DTX asking if amateurs

could assist in locating her brother, whom she had not heard from for twenty years. The only address available was "U. S. Signal Corps Service, somewhere in U. S. or possessions." The message was passed to W6CLH for release on the 3.9- and 14-mc. 'phone bands. W6DTX and W6ECC also sent it forward on 3.5-mc. c.w. with the request that it be relayed to the various Signal Corps Posts. On February 4th an Air Mail letter was received by Mrs. Fredricks from her brother, who had been located at Governors Island, New York—and it was an "amateur radio message" that located him! FB.

With due apologies to the "great fraternity of newspaper reporters" we quote the following from an item found in a local paper by W1CTI. The item deals with Federal agents locating an unlicensed radio transmitting station. The "headlines" read, "Unlicensed Radio Cleverly Concealed," and the reporter goes on to relate: "A short-wave set with a 1000 watt transmitter, the apparatus was grounded on the bathtub and used the electric light line as an aerial. Although the walls of the house are thin, no tenants ever had suspected the presence of a radio. Its instruments were well muffled and no receiving sets in the house had noticed interference. Its range was estimated at 10,000 miles. So cunningly was the radio apparatus hidden that a maid employed to clean the apartment had never noticed it." . . . MIM

W6CIX and W6DOZ were recently working each other on their respective one thousandth QSOs. To make the occasion more memorable they chewed the rag for over an hour in Pig Latin! Try that on your bug—or better yet, "on your mike!"

HAM BROADCAST FROM WMT

The Cedar Valley (Iowa) Radio Club presents an amateur program over WMT, Waterloo, Iowa, each Tuesday evening from 9:45 to 10:00 p.m. C.S.T. Hams within the range of WMT should listen in on these broadcasts, which are reputed to be very interesting.

Route Manager Hal Falk, W8PP, says, "Good traffic originations is the problem of individual stations. If only worthwhile messages leave the station, traffic lanes of the state will not be cluttered and operators will not be burdened to the extent of monotony or disgust." And history shows traffic will move more effectively when discrimination in originations, gained by advising the public, and personal care in making up messages if followed.

ELECTION NOTICES

To all A.R.R.L. Members residing in the Sections listed below: (The list gives the Sections, closing date for receipt of nominating petitions for Section Manager, the name of the present incumbent and the date of expiration of his term of office.) This notice supersedes previous notices.

In cases where no valid nominating petitions have been received from A.R.R.L. members residing in the different Sections in response to our previous notices, the closing dates for receipt of nominating petitions are set ahead to the dates given herewith. In the absence of nominating petitions from Members of a Section, the incumbent continues to hold his official position and carry on the work of the Section subject, of course, to the filing of proper nominating petitions and the holding of an election by ballot or as may be necessary. Petitions must be in Hartford on or before noon of the dates specified.

Due to resignations in the Santa Clara Valley and Los Angeles Sections nomination petitions are hereby solicited for the office of Section Communications Manager in these Sections and the closing date for receipt of nominations at A.R.R.L. Headquarters is herewith specified as noon, June 14, 1934.

Section	Closing Date	Present SCM	Present Term of Office Ends
Kansas	July 16, 1934	O. J. Spetter	July 28, 1934
Southern Texas	July 16, 1934	David H. Calk	Aug. 8, 1934
Nevada	July 16, 1934	K. L. Ramsey	Aug. 15, 1934
Saskatchewan*	Aug. 15, 1934	Wilfred Skafie	June 15, 1934
Santa Clara Valley	Aug. 15, 1934	Bruce Stone
Mississippi	Aug. 15, 1934	Wm. G. Bodker	Jan. 15, 1933
Virginia	Aug. 15, 1934	R. N. Eubank	Dec. 15, 1933
Eastern Florida	Aug. 15, 1934	R. L. Atkinson	Dec. 15, 1933
Alaska	Aug. 15, 1934	Richard J. Fox	Feb. 16, 1934
Tennessee	Oct. 1, 1934	F. F. Purdy	Oct. 14, 1934

Southern New Jersey	Oct. 1, 1934	Gedney Rigor	Oct. 14, 1934
San Joaquin Valley	Nov. 1, 1934	G. H. Lavender	Nov. 14, 1934
Colorado	Nov. 15, 1934	T. R. Becker	Nov. 30, 1934
Arkansas	Dec. 5, 1934	Henry E. Vette	Dec. 15, 1934
Louisiana	Dec. 5, 1934	W. J. Wilkinson	Dec. 15, 1934

* In Canadian Sections nominating petitions for Section Managers must be addressed to Canadian General Manager, Alex Reid, 169 Logan Ave., St. Lambert, Quebec. To be valid such petitions must be filed with him on or before the closing dates named.

1. You are hereby notified that an election for an A.R.R.L. Section Communications Manager for the next two-year term of office is about to be held in each of these Sections in accordance with the provisions of By-Laws 5, 6, 7, and 8.

2. The elections will take place in the different Sections immediately after the closing date for receipt of nominating petitions as given opposite the different Sections. The Ballots mailed from Headquarters will list the names of all eligible candidates nominated for the position by A.R.R.L. members residing in the Sections concerned. Ballots will be mailed to members as of the closing dates specified above, for receipt of nominating petitions.

3. Nominating petitions from the Sections named are hereby solicited. Five or more A.R.R.L. members residing in any Section have the privilege of nominating any member of the League as candidate for Section Manager. The following form for nomination is suggested:

Communications Manager, A.R.R.L. (Place and date)
38 La Salle Road, West Hartford, Conn.

We, the undersigned members of the A.R.R.L. residing in the _____ Section of the _____ Division hereby nominate _____ as candidate for Section Communications Manager for this Section for the next two-year term of office.

(Five or more signatures of A.R.R.L. members are required.)

The candidates and five or more signers must be League members in good standing or the petition will be thrown out as invalid. The complete name, address, and station call of the candidate should be included. All such petitions must be filed at the headquarters office of the League in West Hartford, Conn., by noon of the closing date given for receipt of nominating petitions. There is no limit to the number of petitions that may be filed, but no member shall sign more than one such petition.

4. Members are urged to take initiative immediately, filing petitions for the officials for each Section listed above. This is your opportunity to put the man of your choice in office to carry on the work of the organization in your Section.

—F. E. Hanady, Communications Manager

ELECTION RESULTS

Valid petitions nominating a single candidate as Section Manager were filed in a number of Sections, as provided in our Constitution and By-laws, electing the following officials, the term of office starting on the date given.

Los Angeles	Howell C. Brown, W6BPU	June 14, 1934
Iowa	Phil D. Boardman, W9LEZ	June 14, 1934
Nebraska	S. C. Wallace, W9FAM	July 1, 1934
Western Pennsylvania	H. Grossarth, W8CUG	July 1, 1934
Wisconsin	Harold H. Kurth, W9FSS	July 1, 1934

In the Western Massachusetts Section of the New England Division, Mr. Percy Noble, W1BVR, and Mr. Earl G. Hewinson, W1ASV, were nominated. Mr. Noble received 63 votes and Mr. Hewinson received 54 votes. Mr. Noble's term of office began July 6, 1934.

In the Northern New Jersey Section of the Hudson Division, Mr. John Ridge, Jr., W2EKM, and Mr. Robert W. Maloney, W2BRY, were nominated. Mr. Ridge received 148 votes and Mr. Maloney received 139 votes. Mr. Ridge's term of office began July 6, 1934.

In the Illinois Section of the Central Division, Mr. Fred J. Hinds, W9WR, and Mr. Albert A. Herrmann, W9ANQ, were nominated. Mr. Hinds received 361 votes and Mr. Herrmann received 69 votes. Mr. Hinds' term of office began July 8, 1934.

In the Indiana Section of the Central Division, Mr. Arthur L. Braun, W9TE, and Mr. B. J. Biederwolf, W9CHA, were nominated. Mr. Braun received 129 votes and Mr. Biederwolf received 75 votes. Mr. Braun's term of office began July 19, 1934.

ATLANTIC DIVISION

EASTERN PENNSYLVANIA—SCM, Jack Wagen-seller, W3GS—30K alone makes BPL 8LRI is QRL stone crusher. 3DYX is making trip to 9USA. 3EOP graduated from Easton High. SASW prefers trout fishing to radio. 3EIM is c.c. on 7 and 14 mc. 3DWZ has two ops; Ex-YL now has a ticket. 3COZ and EGA report for first time. 3EAV has two new members in his net. 3AKB installed new '66s. 8LTZ, opr. at 8LUI, is going home. 3ECD works A.A.R.S. schedules daily. 3CL reports for 3TX. 3MC works QRL Lansdowne Club Hamfest. 3EPJ is building Tri-tet. 3GS is DX-ing on 14 mc. Over two hundred attended FB Hamfest of Lansdowne Radio Club.

Traffic: W3DYX 3 EOP 66 OK 734 EIM 10 CB 56 DMF 16 DWZ 79 COZ 10 EZ 210 EAV 31 AKB 262 ADE 3 FCD 64 CL 339 TX 6 AQW 1 MC 178 GS 24. W8LRI 20 ASW 8 VD 48 LUI 35 FLA 207.

MARYLAND-DELAWARE-DISTRICT OF COLUMBIA—SCM, E. L. Hudson, W3BAK—W3CXL, 3CQS, RMs. W3BWT, Chief RM. ASO spends week ends at his cottage on the Chesapeake. BAK (Roland) is taking SW receiver to Scout camp Rodney on the Chesapeake; he's camp bugler. CDG worked a K6. OZ-EHW has '60 in final. EKH handled message to Gov. Hawaii. BRS and DYO are rebuilding. DKM is laid up with game leg. DZK made 33 contacts in portable contest. CIQ works 3.9-mc. 'phone all day. DQ attended Pittsburgh Convention.

Traffic: W3CXL 4339 BWT 517 BND 328 ASO 77 CIZ 69 BAK 52 CDG-OZ/EHW 6 EKJ 31 DRE 4.

SOUTHERN NEW JERSEY—SCM, G. M. Rigor, W3QL—ZI carries bunch of schedules. D.V.R.A. has new club quarters in Lawrenceville. NF is now ORS in our Section, EDP is O.O. for Trenton. Anyone in lower So. Jersey interested in A.A.R.S. get in touch with APV. New officers Atlantic Radio Club: Pres. 2AWR, V.-P. Ed. Schofield Sec. 3APV., Treas. UT, Steward BWW, Chief CYI. BEI has rig on 1.7-mc. 'phone. S.J.R.A. is planning a "different" 56-mc. hunt for Aug. 19th. For information write BEI. S.J.R.A. heard Mr. Charles Stewart and Mr. Tuska, Vice-President and First Treasurer of A.R.R.L. respectively. SM is working hard with N.C.R. Active So. Jerseyites: ARV, DST, DNU, AYA, BYR.

Traffic: W3BEI 48 DNU 3 APV 114 EDP 17 NF 41 AEJ 7 ARV 58 ZI 103 QL 2 BYR 5 AVJ 6 DST 4.

WESTERN NEW YORK—SCM, Don Farrell, W8DSP—KMS has a '53 perking on 2.1 meters. JTT is high traffic man. KMC is new O.R.S. JQE has several schedules. FYF is taking vacation. Jamestown Club members plan another treasure hunt. BQJ wants O.B.S. AEK reports by radio. GWY will spend two weeks with Fleet Reserve. ERZ works VKs. EBR visited Malone gang. GZP was married short time ago. KKR has pair of 800s. DHU uses portable around Lake George. CO has new FBXA. EUY had 121 foreign contacts during month. LGR reports fine time by Utica gang on Field Day, June 9th and 10th. S.T.T.A. had nice QSO party. AKC won, working 103 stations in 22 states and 2 foreign countries in one week. IMR received a card and picture from a VK5. AYD was visited by 9OFE. GZM uses Tri-tets. LUJ added a buffer and amplifier. MCT reports for first time. LGN is building new rig. BGN has fun on 56 mc. Tri-County Radio Club had fine outing and Field Day on Canandaigua Lake. AQE now has an a.c. line at Sodus. Tom and John at AFM are doing considerable experimental work on cathode ray outfits. Mrs. R. E. Baxter, LHS, was judged the best looking OW at convention of Central New York Radio Club. New calls: MBI, MCI, MCT, LGN. 4CWC is operating at Penn Yan. F.L.T.S. had a fine time on their outing at DME's camp on Owasco Lake. The Fort Stanwix Club is active. DSS has trouble with Tri-tet.

Traffic: W8JTT 617 DSS 591 KMC 340 JQE 139 FYF 67 ON 42 BQJ-AEK 40 GPT 36 GPS 30 DBX 22 GWY-ERZ 29 EBR 17 DHU-JTH 16 FMX 15 CO 13 EUY 8 IDJ-FYC 6 LGR 5 GWT 4 IMR 3 AXE 2 AYD-GZM-LUJ 1.

WESTERN PENNSYLVANIA—SCM, C. H. Grossarth, W8CUG—KWA attended convention. GUF is rebuilding with RK20. JZZ received O.R.S. C.Q.A. has been teaching beginners the code. GJM is responsible for the fine entertainment at Convention. PX is poking out with 1.75-mc. 'phone. GSV says BAO changed QRA again! Out of a dozen trees FKU had to pick one that would blow down to put his Zepp on! KSG says CDH is on 1.75-mc. 'phone. KTP has new antenna. KQQ has '04A final. HWE was reported one of three most consistent Ws in Australia. FZG is going to Ft. Meade for training for C.C.C. job as radio operator. AVY worked hard as Secretary of Convention Committee. HGG resigned as RM. GUF is appointed R.M. in HGG's place.

Traffic: W8KWA 123 GUF 204 KD 82 JZZ 43 AXD 31 CQA 17 CKO 13 PX 5 GSV 11 FKU 7 HMJ 5 KSG 2 KQQ 1 KRG 4 GBC 5 CUG 12.

CENTRAL DIVISION

ILLINOIS—SCM, F. J. Hinds, W9WR—RM 9AND and 9ERU. ABA, EMD, DTN, POO, CSB and GG are on 56-mc. 'phone. MLH visited Kansas City hams. OLA is treasurer of Downers Grove A.R.A. CUH is trying to get on 7 mc. HKC was hit by lightning. DBO uses crystal lock system. DDO sends first report. MAJ schedules CBA. LOJ bought new headphones. AD is trying 1.7-mc. 'phone. NIU and IEP took a portable to Free Soil, Mich., for a test. BPU and CFV are installing '52s. FO would like to hear from any ham who contacted "VU2CP" during June. DGT found a job. New rig at PNE is working well. AFN has antenna with copperweld wire. ACU, HUX and ODB went out on portable field day with the YLs. LW's input is 800 watts on 7 mc. and 450 on 14 mc. IZP worked a "G". IWR worked his first VK. EQX heard ZLICD on 3.9-mc. 'phone. NN is V-8-ing to Mexico, California. Crystal troubles at PIO. RDU is building c.c. rig. BYZ says 28 mc. has no dead spots like 56 mc. OA, GZK and OKZ built 56-mc. rigs after seeing a demonstration at radio club by AVB and RZL. DJG had AIU on air for field day. ERU and AND (new R.M.s.) attended Rock Island Hamfest. KEH visited World's Fair. Antenna trouble at RCQ. KIT sticks to 7126 kc. NDB has success with Collins system. RXV is new in E. St. Louis. OVV says, "I'll be at the Fair." PVG works 3.5 mc. and 14 mc. DLO gets out on 7 mc. Receiver trouble at OVS and OZJ. OXA is c.c. on 3792 kc. BRX is now O.R.S. PQM left for U.S. Naval Academy. HQH wants to hear from those near him on 56 and 28 mc. COW says a 33-foot antenna under the parlor rug pokes out as well as the outdoor affair. HI. USA has been heard in many foreign countries. ORX worked South America on 3.5 mc. KJH has B.C.L. trouble. RLP and EAL are rushing the same YL!

Traffic: W9HKC 595 DOU 506 HPG 393 ILH 384 KJY 328 MIN 189 LW 155 AD 141 MDL 85 CKC 74 CGV 59 USA 36 DJG 35 KEH 34 MLH 33 DBO-NN 29 HQH-IEP 22 AFN 21 DGT 18 MAJ-PBQ 15 CUH-DDO-PQM 14 NIU 13 FO 11 ION 10 AVB-LIV-LOJ 8 PYZ-GKH-IZP 7 EMN-FCW-AIU 6 RCQ 5 AND 4 KIT-POO-RDU 3 NDB-OVY 2 BPU-BYZ-WR 1.

INDIANA—SCM, A. L. Braun, W9TE—9FQ, Chief R.M. AXH has given up c.w. MQV is home for summer. DJU has three all-wave receivers. DET is new O.R.S. HTP likes the 830. HVO blew rectifier tubes. CKG works 14, 7, 3.5 and 17 mc. RIG is new at West Lafayette. HBK has a job at Marion. FQ is chief R.M. Indiana. GGP has a '45 Hartley. JST moved to Santa Rosa, N.M. HUV is giving 28 mc. a try. BU4, 38th Div. Aviation, will op. on 4210 kc. with 1 kw. rig from Aug. 4 to 19th. FVI has new QRA at Speedway City. GFS is lining up schedules. HIU moved to Miami. RTF has c.c. rig. MQQ works plenty DX. TE has new tri-tet. OKX has visions of a 'phone.

Traffic: W9AXH 8 MQV 1 DJU-DET 15 HTP 22 HUF 11 CKG 7 PQL-RIG 2 HPQ 10 FQ 4 GGP 2 TE 2.

KENTUCKY—SCM, Carl L. Pfummm, W9OX—ETT wins first prize of pair '66s. FGK takes second prize of A.R.R.L. membership, and BWJ gets bottle of Crab Orchard! HBQ is new O.R.S. AUH has new baby girl. BAX is installing new equipment. IXN and EDV attend meeting of A.R.T.S. After keeping schedules continuously for six years, OX is temporarily off air. FQQ is specializing in paper products (?) RBN finds DX good on Ohio river camp. JYO gets relief as score-keeper during hot months. FZV is considering 'phone. New mast helps HCO's sigs. NEP is on 7 mc. EYW is on diet preparing for Ky. ham picnic. ERH is leaving for Fort Knox with Portable transmitter. OMW-DGN-NMQ visit World's Fair. IPG is coming back on air. Ole Man Ribber has ELL afloat. OFE reached Cambridge, Mass., okay and is looking for Ky. gang from IBRI. MEET THE ENTIRE KY. GANG AT THE KY. HAM PICNIC IN LOUISVILLE ON SEPT. 2ND. Plenty of good eats, barrels of Hi-Bru, lots of fine prizes. Send in your reservation with two bucks to HBQ, Sec'y before Aug. 15th. Price is \$2.50 after Aug. 15th.

Traffic: W9BWJ 76 EDQ 55 HBQ 53 HAX 52 AUH 51 BAZ 39 IXN 33 OX 30 BJA-FQQ 26 RBN 16 JYO 15 EQO-CDA 13 FZV-PXX 6 HCO 4 NEP-FGK 2.

MICHIGAN—SCM, Kenneth F. Conroy, W8DYH—Much portable work is being done headed by JO. Would appreciate a note from everyone knowing the whereabouts of radio hams enlisted in C.C.C. in Mich. Plans for a state wide C.C.C. net are underway. Free D.A.R.A. Bulletin to all stations reporting active. MICHIGAN NINES: AAM working with FFP, CSI and HSQ on Ishpeming forest-fire helped to save a lot of timber. PDE is rebuilding for Munising job. CWR prepares for forest-fire work. SCEU awaits a 9 call. EQV reports EGF on daily. LKJ reports RRP new in town. KDE reports for JCN. RHM joins A.A.R.S. OXL summers at Forest Lake. LUU reports FBC starting for L.P. but last heard of from LIP, St. Paul! NEZ, LHW and BBP chewed rag at Soo speak when BBP's boat docked there. CWD handled message to Postmaster General when U.S. Mail service was cut for Isle Royale. CE hooks lots of VKs. OVX uses '47s P.P. '46s. ADY is in PCU's "Romeo Network." MICHIGAN EIGHTS: DVC leads state. FTW BPLs on deliveries. QT vs. CPY teams of beer drinkers had great contest. FAV had the smallest capacity. (22 schupferarads.) GUC'g A.A.R.S. lineup puts HL 1st alternate and QT 2nd alternate SNCS. KOX is trying to get trunkline into Dixie states to work with DVC's east-west line. EGX and ARR are newest O.R.S. FQF and CVF are latest O.P.S. IOR reports GPH working in Chicago. LAL is starting Navy net. IQS schedules IMK and 7QI. BMG using "Gizzlebloom's Guaranteed Hair-restorer" finds shaving unnecessary! DED, on 28 mc., hopes to win BIU's prize crystal. JKO reports MBP new. GQB reports EGF oping on yacht. GHP moved to 14 mc. The DYH's have gone portable-nuts since listening to JO's talk at D.A.R.A. All's well at Stony Point, HNB. GRN and BTK hooked J2GX for W.A.C.! IKO built receiver for S.W.L. HA finds better sig with 100 watts input. ICM is c.c. on 3559 kc. LSU sends first report. MV is scheduling Camp, HFB, CTD got married! Congrats. IXM's new phone song: "Of The Heising, Baby." GWA schedules TG at Camp Muskegon. Congrats to KPL—new Jr. opr! Best story: HFU was invited to IKZ's to listen to new s.s. receiver. IKZ is 1.7 mc. man. HFU assumed receiver was on 1.7 mc. and was amazed to hear 6's and 7's rolling in on speaker at high noon! IKZ was trying out 14 mc. coils!!

Traffic: W8DVC 427 QT 374 FTW 208 GUC 175 DWB 137 KOC 124 EGX 94EGI 88 IOR 54 LAL 54 CPY 51 IPX 39 IQS 35 KYS 32 JCS 28 BMG-DED 25 JKO 17 GSP 18 GQB 16 GHP 15 AIJ 14 ARR-DNM 12 DYH 11 HNB-JYP 10 GRN-IKO 9 BGY-HA-ICM 8 IFQ 7 IFD-LSU-MV 5 DSQ 4 DCQ-FX 2 BTK-IKZ- JNK 1 KMT 12. W9ADY 60 PCU 50 OVX 31 CE 25 CWD 20 NEZ 16 LUU 15 OXL 14 RHM 11 KDE 6 CWR 3 IOV-JCN-LKJ 2 EQV 1 OZM 16.

OHIO—SCM, Harry A. Tummonds, W8BAH—Chief Ohio R.M. SVP. All-Ohio day was big success. HCS won crystal given by SCM. Following placed in order shown: HCS first, 31 contacts, ANU-19, AQ-12, HMH-10, Bah 4. District No. 2: RM W8EEZ. EEZ says INX and ITD are rebuilding. UX is policeman at steel mill. Dist. No. 5: BMK is rebuilding for 14 mc. FGV, R.M., is proud owner of W.A.C. cert. AMF is laid up with sore ankle. KLP's new QRA: 112 Ravine St., E., Liverpool. KWJ worked HC1PZ for 22nd country. AZU graduated from Case. AQ is now O.R.S. Dist. No. 8: JIN sends first report. BKE's new QRA: 124 Mingo St., Circleville. BRQ, R.M., has 500 watts input. Dist. No. 7: R.M. VP: EQB hears locals on 14 mc. GNG has Class A ticket. Dist. No. 3: Act. R.M. APC: JGZ applies for ORS. LZK schedules HNB, LCY. LCY will take over HCS schedules while he is rebuilding. Dist. No. 6: FQC has power leak difficulties. HTI is back after 10 months' QRL. JFZ schedules IPX and IET. HEY blew 211, '52 now. HWC's new QRA: 1435 Kehr Place, Columbus. MCU got new call after making 9FGV BT8 famous in Ohio. GSO, R.M., is going on 7 mc. for summer. GDC is Chief Ohio Phone Activities Mgr.; he

worked G5BY on 'phone. Dist. No. 4: UW, R.M., is busy with A.A.R.S. IET handles West Ohio traffic for two trunk lines, Canada to Fla. and N.Y.C. to Calif., Hawaii, KA1HR and China. FB, OM. WE's OW put foot in power supply during portable day contest while QSO Camp, PO. Dist. No. 1: BAH spent day with PO on banks of Sandusky River during Field Day. CIO schedules Army. FGC is ready for schedules. BON, R.M., says L.R.C. had FB time on Field Day. DAT has crystal on 3855 kc. BAC, a veteran O.R.S., never misses a report. KKT operates on farm. KZL's new QRA: Cleveland Heights. FVL's new QRA: South Euclid. LVA, East Tech. High School, held Anniversary exhibition. Following took part through amateur radio exhibit: LVA, KTB, LBF, KZX, LXS, LJK, LJJ, LYO, LYM, HXK. J. L. Reinartz was guest at Cleveland Free Hamfest sponsored by BAH June 12th. 325 turned out to meet John L.

Traffic: W8UX 1 ANU 13 BMK 1 FGV 2 AMF 8 KWI 1 HCS 509 AQ 31 JIN 10 BKE 6 BRQ 11 EQB 25 GNG 3 HMH 27 VP 79 LZK 35 AEW 3 DIH 1 LCY 91 EQC 6 DZO 2 GZ 8 JFZ 33 MCV 40 GSO 22 UW 229 IET 116 WE 23 BAH 20 CIO 154 BON 44 EPP 75 DAT 6 BAC 28 KKT 12 FVL 16.

WISCONSIN—Acting SCM, Carl F. Thoms, W9LFK—FSS is out of town for three months. Report to ATO via radio or mail. ATO leads state. IQW says traffic good. ETM is doing 56-mc. work. KPO is going to radio school in New Orleans. OXP's mast came down in storm. GVL is looking for 14 mc. DX. LFK is trying to make tri-tet work. HGF is putting 300 watts into 211. OTL visited IQW. PRL visited ATO with NSM. RSA is building new receiver. BXZ reports for Burlington gang. HTZ and BXZ joined N.C.R. HFL has new transmitter. GIT has new Jr. op. JDP cracked top off '52. Sheboygan Radio Amateurs Club is holding picnic July 22 at Columbia Park on Lake Winnebago. IYX will trade a 1.7 mc. X cut crystal for a 3.5 mc. X cut. DNU is rebuilding to RK20. JAN is finishing rack and panel job. OXP is after O.R.S. RCC is new Racine ham.

Traffic: W9ATO 233 IQW 109 ETM 75 NSM 54 KPO 34 OXP 27 JCW-GVL 13 LFK 12 HGF 4 PQU 8 PRL 2 RKP 8 OTL 4 HSK 104 JNU 16 DNU 5 OXP 28.

DAKOTA DIVISION

NORTH DAKOTA—SCM, Fred J. Wells, W9JVP—OSN and LES are new O.R.S. PAI is new RM for West half of States. KBE is RM for East half. PGO and JQG are at N. G. Camp. JAR uses low power. IKF of Minneapolis visited OSN. PDC has a 'phone on the air. LHS puts up new sky wire. OEL reports two new calls in his city, RYZ, an old navy OP, and RQX. HJC is QRL stork, vep it is another YL, fellows. LBI is putting in O4A. BTJ orders new RK 20. PTJ uses 33s. KZL has portable rig. EHK is back on air with 4BN of Crosby, Minn., at the key as second OP. SCM is putting in class "B" phone. DOY has new receiver. EIG returns with a Hartley. EOZ rebuilt CBM. DGS entered field day with flea power portable.

Traffic: W9HJC 47 JVP 37 PDC 22 PGO 20 OEL 15 LHS 17 OSN 10 KBE 12 FSF 9 PQW 8 BTJ 7 KZL 9 MZE 7 JAR 16 EFN 5 PRU 10 DGS 21.

SOUTH DAKOTA—SCM, Mike G. Strahan, W9PFT—W9TY is building a portable. PFI has new shack. AVP married that YL!! OED called on PHP and RSE. BLZ has new one kiv rig. LDU is working in Rapid City. PHP is building new rig. GPB is working in Sioux City, Iowa. DIY made two 56 mc. transceivers. DNS has new job. State A.R.R.L. convention at Huron was well attended. Congratulations to the Huron Amateur Radio Club.

Traffic: W9TY 8 PFI 5.

NORTHERN MINN.—SCM, Robert C. Harshberger, W9JIE—W9OMI visited W9USA. OOO is on 7 mc. DKL, former SCM S. Dak., now in St. Paul, was in accident resulting in 6 stitches.

Traffic: W9OMI 6 OOO 7 FTJ 7 HNS 6 RAG 11 OOU 20 JIE 51.

SOUTHERN MINN.—SCM, F. C. Kramer, W9DEI—

W9FCS is working in an oil station. GUX uses c.c. RAU keeps schedules from scout camp. GNU keeps his transmitter locked. DEI has new hi-voltage condensers. PDL moved to summer home. BNN reports prospective ham in Ovoca. OAK won a 7UE fish line belt. DH is building class B 'phone. RAB is experimenting with the effects of R.F. on the separation of minerals. FNK spends his time at his lake side cottage. KDI was called out to squelch the Mpls. strike. PJH took a portable into north woods. FYA built a transmitter for 7 mc. EGG is working on new 'phone. FWN has two 'O3A's on 14 mc. BXC operates a portable 'phone in a cow pasture.

Traffic: W9FCS 36 GUX 29 RAU 26 BN GNU 24 DEI 24 HCC 17 PDL 17 BNN 5 OAK 5 DH 4 RAB 2 RKG 1.

DELTA DIVISION

ARKANSAS—SCM, Henry E. Velte, W5ABI—BMI made B.P.L. DVR is bothered with feed back. DWD has new 50-watter. DJE will use pair 'O3As. DTI and DYT spent 3 weeks at Camp Bonanza. DVI and CZG, co-operators, say their six bit 10's are about shot. ABL is on 7050 kc. BDB built s.s. super. 9EDK is new O.R.S. 5AXP sold out to CEO, who is on 1.7-mc. 'phone. 4AJJ applied for 5 call. 5DRZ has new crystal. JK reports batteries down. CVO had visit from 7BLT. DYF is on 3.5 mc. DYX has new masts. EFJ is new L.R. station. CPV visited Hot Springs hams. ANZ is installing 250-watter. DWL took in World's Fair. DYI schedules DTL. ASG has 6 SWL cards from England reporting 14-mc. 'phone. VZ has '46s final. ANR has gas well on his place and uses it to run power supply.

Traffic: W5BMI 510 DVR 43 DWD 42 DJE 41 DTI 38 DVI/CZG 12 ABL 9 DEV 7 BDB 5 DRY 4. W9EDK 3.

LOUISIANA—SCM, W. J. Wilkinson, Jr., W5DWV—DKR is new R.M., South La. CXQ gives prizes at N.O.R.C. BPL applied for A.A.R.S. membership. HR is old 'phone man. CWX is experimenting with 56 mc. AEH is now A.R.R.L. member. AOZ is an N.O. "cop." PW is another police official in N.O. JW is counsel for N.O.R.C. DMF keeps club rig hot. DYR is N.O.R.C. call. DES is rebuilding for 14-mc. 'phone. ACV is at sea most of time. EDZ is on 7070 kc. NM is cruising again. MO is helping build gin. IG is Paper Co. worker at Hodge. BQO bought transmitter from ADJ. DJS is homeward bound from London. AXU and VT-DWW visited AKI and ZS. EBB moved to Shreveport. EAI is on 1.7-mc. 'phone. AKW and BFB are home for summer. New hams: EAY, EBZ, EDY. DMP's masts blew down in storm. CYI works DX. DAW moved to Monroe. The New Orleans Radio Club is conducting a training course for beginners.

Traffic: W5BI 3 DKR 24 CXQ 5 BPL-HR 2 CTR 3 DLD 2 BID 30.

MISSISSIPPI—Acting SCM, W. P. Allen, W5VJ—DEJ is operating portable at Boy Scout Camp Binachi and is handling traffic between the Camo and Meridian. CWQ schedules 5MN, 4PL, 5 CLD and 4BJA.

Traffic: W5CWQ 20 DEJ 22.

HUDSON DIVISION

EASTERN NEW YORK—SCM, R. E. Haight, W2LU-BLU worked first foreigner. LU and BSH attended Hudson Division banquet. BGF moved to Sch'ty. BJX is member of A-1 OP Club. GTC helps BRS drive new Henry. FQG is on 7 mc. W1EFM-2 is back at Pittsfield. DSH reports QST broadcast via WEAF. DYC was visited by 8AW from Detroit. KW uses O3A final. UL is painting the shack. CC is hitting DX. DC works Europe on 'phone. GTW reports 56-mc. activity. ATM was on N.C.R. active duty. HCZ had 100 QSO's in month. ESO is out of college. BLL got a Silver 5B. ACY had 32 DX contacts. FXC is rebuilding. BCO attended Hudson Div. Convention. CVT is building new rig. DDW plans visit to World's Fair. GWY works DX on 14 and 7 mc. CJS is painting and house cleaning. CBN is in Brooklyn for summer.

CVL and COY joined N.C.R. CPQ and SCM had FB QSO. HCV is pounding out in Sch'ty.

Traffic: 2BZZ 513 BLU 410 LU 249 EGF 332 BJX 295 GTC 80 FQG 71 BJA 62 WIEFM-2 52 DSH 22 DYC 18 KW 16 UL 14 CC 14 GPB 13 DC 7 GNI 6 AJE 4 GTW 4 ATM 3 ACA 3 HCZ 1 ESO 1.

N. Y. C. & LONG ISLAND—SCM, Ed. L. Baunach, W2AZV—EYQ wound 2000-volt transformer. ELK is acting N.C.S. for Southern N. Y. DJP has C.C. rig. EYS was heard in Austria on 3.5 mc. KI sent first report in 10 years. CYX schedules R. I. 3 days a week, FF is building new antenna system. CSO has 52's PP final. CCD is on 14-mc. 'phone. FIP changed shack around. DOG participated in portable field day. FCQ reports new ham, HDT. FBE received card from a YL in Germany, who heard his sigs on 7 mc. BTF was laid up with injury to left eye. AEN reported EXQ got married; it should have read "EXM got married in March." AZV is trying new Hertz. BKP took the final leap. BUU has new 66's. CBB was heard in Poland during the S.S. DWW is going 56 mc. for summer. BAS is at new QRA, 128-73rd St., B'klyn. AUF operates on 1893-ke. 'phone. US is using RK20 and '52's. AXN is with Emerson Radio Co. HBK is a new station in N. Y. C. AOC, the Williamsburg Radio Club, had a power transformer stolen from their club room. FNF is working on 'phone job. FBE reports new club organizing in Greenpoint: CHT, pres.; FBE, v.-pres.; EQE, treas. CRL, ERH, FDU, EDZ are trying 56 mc. EQU worked Holland with 110 volts. ARG is back after a five-year layoff. EFB holds a Class-A ticket. FLW worked destroyer *Boggs* when the fleet was in Hudson River. AEN worked CT2BK, who was using 'phone on 7 mc. BEG is at new QRA in N. Y. C. EVA reports that Astoria Club was guest of Sunrise Club recently. AHC, DJO, WQ, DXO of Northern Nassau Wireless Assn. did a fine job of Tri-Club hamfest and outing. BVT is chief electrician of Woolworth Bldg. AOB uses 52's final on 3.9-mc. 'phone.

Traffic: EYQ 416 ELK 466 DJP 165 CHK 129 AYJ 99 EYS 93 PDQ 52 KI 39 CYX 33 GLJ 27 FF 24 GDF 14 CSO 14 CCD 8 CEH 6 FIP 5 DOG 5 EQA 4 FCQ 3 FIK 5 GUA 4 EDZ 2 BRB 2 FBE 2 BTF 1 EVA 1 AEN 42 AZV 38 BKP 15 EGA 4 AGC 1 AYT 2 AA 6 LB 20 BYL 6 BVT 2 ADW 6 GZ 6 AOB 8 ASG 6.

NORTHERN NEW JERSEY—Acting SCM, Robert Maloney, W2BPY—EKM gained much gratitude by sharing his beer with BCX and BPY at the hamfest. BCX is new RM. CJX spends of his time on 7 mc. CLM handled traffic with VP5MK and D4BAR. FOP will be at camp in 8th district until Sept. 1st. LK is an A.A.R.S. ECO and DBH received Class-A ticket. FLT was heard in Germany two days in a row on 3.5 mc. GGE has rapid-fire change system to all three bands. GVZ has rack and panel 450-watt job. BXM is working on 3.9- and 1.7-mc. 'phone mainly. ESX claims his troubles will keep him busy for next ten years. BVJ is another WAC. FMN starts out with his first. BPY is still trying to put "That Hartley" together. The T.C.R.A. brought all hamfest records to this Section in putting over the Perth Amboy affair on June 16th. With an actual attendance of over 1200, and a swell program, they have left memories of the finest fest ever held. Ed Whitnah, ex-2DIU, is now 9RYD in St. Louis, got radiotelephone first-class ticket.

Traffic: EKM 1824 BCX 1534 ENZ 571 CTT 28 CJX 26 CIZ 12 DPB 7 CIM 7 FOP 7 LK 47 ECO 27 FLT 6 DCP 3 GGE 10 FMN 1 BPY 3.

MIDWEST DIVISION

IOWA—SCM, Phil Boardman, W9LEZ—9ABE, Chief RM. 9HPA, RM. Thanks for the new job, boys. Will do everything in my power to make our Section a leader. Please mail your future reports to me at 325 Kirkwood Blvd., Davenport. Tri-City Amateur Radio Club announces a most successful hamfest with over 300 amateurs registered. LEZ makes BPL. CWG divides time between traffic and rag-chewing. ADD is building 14-mc. 'phone. NTA reports for NUC. NUC worked 3 K6's. NZW desires ORS. KMJ is on 3.5 mc. MXO is

on summer vacation. IOJ's antenna blew down. NTW works 3.5 mc. with 15-foot antenna.

Traffic: W9LEZ 512 CWG 56 ACL 16 LCX 113 NTA 13 NUC 7 NZW 52 RDX 3 NTW 3.

KANSAS—SCM, O. J. Spetter, W9FLG—9KKG and 9IOL RM's. 9ESL, 'phone RM. MUY moves to Topeka. KYV is new OPS. OFR is QRL Hamburger joint in Sabetha. PKD is Temp. 4th DNCS. IOL is Temp. SNCS. NJS is temp. ASNCS for summer. BEZ and NLZ plan USNR cruise. MJS is trying c.c. Portable 6KCW in Wichita applied for 9 call. HTF is on again. LKD uses 59's with Class-B modulation. LFB is building 2-volt battery-operated Super. AWP, after operating CX7 for three years, will be at the other end of schedules this year. DMF is putting in '03A. DSD got hitched June 3rd. Congrats, OM. DSD and AYE are at KFJ plant. IGY has new 'phone. GML is on 14-mc. 'phone. HWW has new receiver in Armory. NLZ is active in NCK. APF took flea-power (2-watt) 3.9-mc. 'phone on vacation in Ozarks, and kept schedules with home port. PUX is in Amarillo, Tex., awaiting 5 call. HUB and OW entertained SARC with a cherry pie feed. BCY and FMX plan 56-mc. field day. FMX, CNW, GWY, PMA were on field day June 9th-10th, but nary a QSO. EMT is with Seismograph Oil Survey Co. in Texas. BO has TPTG using '03A. IXE has Radiotelephone 2nd. GCU has many crystals. JUX has new bug. MBK moved to Parks, Ariz. POM has '45's P.P. ASY works 1.7-mc. 'phone. IEW has contract to build Leavenworth Police Radio Station. OXQ is ex-Commercial OP. IXV is on 3.9-mc. 'phone. KFQ has 7-mc. crystal. PZW, RBH and RYB are new Chanute calls. DKI works spasmodically on 1.7-mc. 'phone and 3.5-mc. c.w. AEY has MOPA with 152 final. JAG is on 1.7-mc. 'phone, also BAW. EVR is active again. FRU is back at Salina from K.U. ATN has new '52. IEE and JDY combine their equipment. NOE and ATN are experimenting with Mobile KNG transceivers to be used at Camp this summer. Rebuilding: ABJ, IGY, 17-mc. 'phone with 211 final; AWB rack and panel job; RNJ 17-mc. 'phone; OER 'phone with 261 final. Club Notes: SARC is taking vacation until Sept. 1st. Large delegation from Wichita went to Winfield, June 7th, for joint meeting with Walnut Valley Radio Club. Beloit hams are organizing Radio Club. Nite Owl Amateur Radio Club had picnic at FEL's, May 20th. Club Secretaries, please keep the SCM informed on your club activities.

Traffic: W9LEZ 126 IQI 50 IRE 39 AWP 26 PKD 23 NLZ 15 HWW 14 CMV 14 MUY 11 PB 07 OZN 03 COA 01.

MISSOURI—SCM, C. R. Cannady, W9EYG—JPT—NNZ turned to 7 and 14 mc. CRM is trying to get rig on 14 mc. HUG antenna is down. DIC attended Kaw Valley meeting at Topeka, Kansas. KVN is contemplating 800 final. GBJ is experimenting with 28 mc. PBZ has silver s.s. super. IAC is working on 1-kw. 'phone. CJL is on 1.7-mc. 'phone. JXG has Class A. KBV and IJW work good DX on 7 mc. BLU is changing to c.c. CHE is experimenting with 56-mc. 'phone. MND worked 4 continents with 10 watts. CGA gets out FB on 14-mc. 'phone. LCG is training prospective hams in St. Joseph. NLS and OCZ works duplex 'phone. MLR is located in Boonville, not Moberly as per June QST. DEN is building new receiver. DLC visited four Sedalia hams. NNF uses O1A's on 14 mc. CCZ moved. FAB wants high-powered tube. NBV changed one RF choke, and is now getting out FB. NBE is trying 14 mc. NEV moved to 1310A Wright Ave., St. Louis. Rebuilding: KEF, LLN, GUQ, GSO, PW, NKS is new member of ARF of St. Louis. KIK is on 3.5 mc. at intervals. HVP has FB c.c. rig. GTK is coming on with c.c. HVN and NEV want ASIA for WAC. SAA and SAE are new hams in St. Louis. PYD is working on new receiver. EFC finally masters 3.9-mc. 'phone. DLB got married. EYG is moving to farm. SMARA meeting was held at Joplin, June 17th. Next meeting to be at Monett third Sunday in August. KANSAS CITY CONVENTION FOR MISSOURI at Hotel President, August 4th-5th.

Big time for all—Registration \$2.00.

Traffic: W9JWI 1796 ALJ 148 ENF 79 NNZ 86 GRM 30 CJR 22 HUG 17 DIC 20 KVN 7 AHH 7 DCB 5 AAN 4 LJW 4 GBJ 1 FEV 58 DPJ 7 BMA 28 GTK 4 EFC 9 BGE 3.

NEBRASKA—SCM, Samuel C. Wallace, W9FAM—DMY has been experimenting. OPP keeps lot of schedules. DGL Champ DXer, is going strong. EWO is organizing N.C.R. unit. DI is going on cruise. FAM is on Sunday morning until 11:30 a.m. RUJ is new reporter. FWW is going after traffic heavy.

Traffic: W9DMY 28 JED 18 OPP 18 DGL 2 MGW 48 DLK 53 RUJ 49 FWW 217 FAM 2.

NEW ENGLAND DIVISION

CONNECTICUT—SCM, Frederick Ellis, Jr., WICTI —1MK gets big thrill QSOing his dad. AMG BPLs on deliveries. DOW hangs on to CBA traffic banner. CVL, CJD, CKF, BDI, "Hal" and UE were active on Field Day. HJW is looking for traffic schedules. BHM is experimenting with antenna. BIH is home for summer. WIBY is new station in West Hartford. The Hamfest at East Hartford, June 24th, under auspices of Hartford County A.R.A. and Manchester Radio Club, was big success; about 350 present! BDI and UE were guests at Conn. Brasspounder's Dinner at Darien on June 14th.

Traffic: W1MK 536 AMG 353 DOW 243 UE 202 CVL 79 FIO 55 BDI 39 CTI 33 GGX 28 HJW 25 EAF 17 BHM 17 GME 14 GKM 12 CJD 11 EAO 7 ES 5 HLE 5 EBT 5 HTH 2 BNP 1 IBT 1 SJ 1 DGG 99.

MAINE—SCM, John W. Singleton, W1CDX—GKC is building receiver. EFA plans trip up Mt. Katahdin for 56-mc. tests. BTQ has new 1.7-mc. phone. CDX portable was on top Walker Hill near Wilton during Field Day. ERB visited SCM. BLI has 800 final. ERO has 59 c.c. rig. CBU has new c.c. rig. EEY schedules S.C.M. EZR is new member A.A.R.S. HXO is on 3.5 and 56 mc. ALO carried on 56-mc. test from Moose Hill. FJP is increasing power. GOJ is under doctor's care. CRP climbed Mt. Pleasant, June 10th, for 56-mc. Field Day. HUX helped operate W1CDX BTI. IDN and IEH are new Wilton hams. FA is experimenting on 56 mc. GLN is working on a farm. New club formed at Wilton, called "The 73 Radio Club," has 15 members.

Traffic: GKC 118 EFA 49 BTQ 45 CDX 42 ERB 41 CHF 16 BLI 13 ERO 3 CBU 6 EEY 6 DHH 7 EZR 15.

EASTERN MASSACHUSETTS—SCM, Joseph A. Mullen, W1ASI—KH is reporting for SCM ASI, who is on his honeymoon. The blessings of the Section be upon them! PRO, our expert YL op, leads the Section! CEL wants mainland hams to QSO on 56 mc. KH was QSO 9BQM and 8LXS on 28 mc. VS, the old reliable, is QRT for summer. CRA says Harvard finals QTA schedules. BZO worked across the pond for first time. ABG was QSO 47 stations in 4 hours portable Field Day. EPO is helping hams handle code. COL reports FB A.A.R.S. traffic for following: GGP, ATD, GBW, ZK, CCL, AZF, DFE, AAR, WX, GZL. Two filter condensers refused to condense for EVJ. FYT gets out with 71A. AGA is again pushing the key. DOF is pleased with his new O.P.S. DFS will be on 28 mc. week-ends. HKK built new Tri-tet and monitor. HZU is active with 56-mc. portable. CWW is back on the air. WV last month was QSO 17 countries, making total 65! IB and XYL, IHOS, started lifetime QSO. Good luck to them. ZO kept 170 schedules on 56 mc. with VT in charge of Boston Post booth at Home Beautiful show, assisted by ASI, HSF, KH, VA, VS, WV, and HOM, who flew over the building twice daily for QSO on 56 mc., to delight of crowd. FH and AF made W.A.C.

Traffic: FRO 214 CEL 96 KH 96 VS 94 CRA 85 BZO 78 ABG 41 FPO 35 COL 26 CZL 95 GGP 91 ATD 55 GBW 53 ZK 48 EVJ 28 BZQ 24 FYT 22 AGA 20 RE 13 DOW 13 DFS 11 HKK 10 HZU 4 GCL 2 FWT 1 CWW 1 CCL 33 AZF 29 DFE 24 AAR 11 WX 11.

WESTERN MASSACHUSETTS—SCM, Earl G. Hewinson, W1ASY-WIRB—BVR reports 24-hour delivery of Orient traffic through A.A.R.S. GZL is new OPS. FNY is at lake for summer. EOB graduated from high school. ERS has 100-watt job. ERZ is building

3/4 kw. outfit. DIE joined c.c. gang. DDK is building a.c. freq. meter. DVW is graduating from college. COI is changing to 59. FRQ finally worked a station on 56 mc. ZB got W.A.C. Hats off to Carl! HHR moved to E. Mass. ASY helped beat his c.w. friends at baseball at Hartford Hamfest.

Traffic: W1BWR 445 GZL 153 FNY 114 EOB 75 ERS 64 DIE 30 EAX 29 HNP 27 AWW 25 DDK 23 DVW 11 GHO 7 COI 6 FRQ 5 ARH 5 IZB 4 DUZ 2 YK 1.

NEW HAMPSHIRE—SCM, Basil F. Cutting, W1APK —FFL leads Section. ERQ joined the Navy, so we won't have his fine reports for a few years! HJI pounds out fine 56-mc. sigs. FFZ has trouble with FB7K. GHT is busy on 56-mc. transceiver. HQE is building 3.5-mc. rig. HTO has Tri-tet. AGO has an FB receiver built by Dr. Pickard. AUY is QRL hamfests. GEY was heard by G5FI on 1.7 mc. FGC operates from Jeremy Hill in Pelham on 56 mc. BDN and HPM operate on Mt. Uncanoonuc on 56 mc. DMI moved to Old Orchard Beach, Me. GKE and HOV operate at DMD on Sunday p.m. 56-mc. tests. FX has best 56 mc. the SCM has heard so far. APK and XYL climbed Mt. Kearsarge, June 24th, and worked 16 stations on 56 mc. EAW works 56 mc. from boat in lake. A unit of U.S.N.R. has been organized in Concord with DMD at the head.

Traffic: W1FFL 297 GHT 29 ELJ 8 HOU 16 FFZ 185 HJI 32 APK 24.

VERMONT—SCM, Harry Page, W1ATF—GAE is telephone lineman. DQK entertained BJP, GAN, 81Y, SFYC, and VE2FD. BD is still grinding crystals. GNF is going to roll up traffic now school is over. AXN is QRL growing family. BJP "spurlors Versenkt" in the Frigidaire milk cooler rush in northern VT. DPO arrived in Wis. OK, but found he lost his OPS ticket in KY (where he stopped over to visit a YL). Har! Har!

Traffic: W1BD 82 DQK 21 ATF 8 GNF 4 GAE 2.

NORTHWESTERN DIVISION

ALASKA—SCM, Richard J. Fox, K7PQ—DJA uses Tri-tet. EBR returned from vacation in Wrangell. BHR is using a Gross outfit. EGC left for vacation trip to States. VH has plenty grief as Radio Engineer for Signal Corps. AOC is heard from Todd. CTU visited PQ. BEU was transferred to Guard Island Lighthouse. AZS schedules VH. CHP finds ZL and VK easy to work. ABW was transferred to Juneau. AOA and CKK are on for summer. ARQ is new ham at Excursion Inlet. BNW was laid up account of sickness. BZX bought a new boat—a converted Coast Guard Cutter. Doctor cut out CP's appendix, resoldered connections, and everything is OK! DWM is building a Tri-tet. EZ has trouble with BCLs. DJZ schedules 6BJM. PQ makes BPL.

Traffic: K7PQ 206 DJA 37 EBR 31 EGC 42 VH 63 CKK 32 DJZ 6.

IDAHO—SCM, Don D. Oberbillig, W7AVP—DMT, KI operate radio section at Idaho. AYP, CHT, AVP, DZO assist as net stations for N.G. traffic. New hams: EMN, ELZ, EMT. BNJ is taking three months' vacation. DSL had a backache from grinding crystals. DZO takes press from N.G. camp for hometown newspaper. BRY, ACP, BKF helped AVP put up new antenna pole. DKY, DBP attended hamfest at Spokane. BAA lost father; condolences of the gang, Lee, CSP, CZO are QRL BCL auto radios. CFX, AHS, BCU are on 14 mc. CAX, CAP are on 3.5 mc. CHV has new c.c. rig. NH joined A.A.R.S. CHT worked F8EO. CSW is dispatcher at Ranger station. BRU wants ORS. Don't forget Jenny Lake Hamfest, Aug. 4th, 5th, and 6th.

Traffic: W7NH 12 AVP 343 BRU 3.

MONTANA—SCM, O. W. Viers, W7AAT—BDJ is rebuilding. DHW has new rig. CNE, ABT, CRE, CEG, AQN, CIX, BZA, and AOD attended Spokane Hamfest. EAQ left for Los Angeles. BVI was heard in Germany. AFS is going high power.

Traffic: W7BDJ 25 AOD 14.

OREGON—SCM, Raymond W. Cummins, W7ABZ—AYV is operating C.C.C. station WUBG. DNP is an O.P.S. DWP is QRL jury duty. DPV works ZL, and VK.

DXY claims world's worst radio location: 60,000-volt line 25 feet from receiver. DJD completed new superhet. CXI is consistent 1.7-mc. 'phone. ANX is regional N.C.S. for Boy Scout net. SY is considering low-power 1.7-mc. 'phone. BLN is busy with Coast Guard. WL has new crystal Comet-Pro. AMF and AJV are running for SCM. UJ is new member of Valley Radio Club. AGZ and AHZ are active members of Morning Breakfast Club on 1.7-mc. 'phone. CFM went back east to convention. AQO is newcomer from Longview, Wash. KL got the 830's perking. BIO finds 2A5 gets better results than 59 in Tri-tet. BGF is O.P.S. number 5. BWD is visiting in Calif. BUF works ZL-1CO on 3.9-mc. 'phone. MF reports new ham in Grants Pass, EMO. CBD schedules K7DJZ, and K7ATF. CMG operated station at Mc-Minnville High School annual visitors' day. Visitors to the SCM's shack: 9DLS, 7DGY, BHT, and EKC.

Traffic: BMA 11 AYW 4 AIG 1 ANX 3 SY 29 BLN 79 WL 6 AMF 12 AHZ 25 DP 22 BWD 18 WR 60 BUF 5 MF 85 CBD 9 CMG 24 COU 50 BDR 2 ALM 2 EBQ 14 DBR 501 ABZ 2.

WASHINGTON—SCM, Stanley J. Belliveau, W7AYO—DRY leads section with BPL total. QI has good transpacific and K7 schedules. This is Wy's 30th consec. report. LD clicked with a ZL. APS is on 3815 kc. BBK sawed crystal into 4 pieces. AWF is trying 7 mc. ALH has some snappy new QSL's. BHH has new skywire. ELJ is new Buckley ham. CZY was in Hawaii for a month. DGY visited Portland hams with EKC. DGN hopes to see HQ gang on trip to Conn. DRK is going to try 28-mc. 'phone. DJJ reports BJX got a heard card from London. CMO got heard card from Austria. DET broke state, hi-jump record by several inches. RL is new O.R.S. AVM clicked OA4AI. CAM is first O.P.S. in Section. Congrats. AYO blew up rig. BUQ rides around with the SCM. END is new Port Angeles ham. DZX has been in Porto Rico. AW is second O.P.S. in Section. By the time this is in print the Washigang hope to have a Section "bull." Will be sent only to those reporting traffic so get busy. The SCM hopes to see you all at the big Northwest Convention in Seattle, Aug. 17th-18th.

Traffic: DRY 512 QI 303 WY 231 LD 126 APS 126 BBK 32 AWF 19 ALH 24 BHH 66 ELJ 13 CZY 101 CQK 6 DGY 5 DGN 10 DRD 67 DRK 14 DJJ 25 CMO 12 DET 7 RL 13 IG 28 AVM 1 CAM 10 AYO 1 BUQ 12 BUX 3.

PACIFIC DIVISION

HAWAII—SCM, A. O. Adams, K6EWQ—GZI is now O.R.S. FJF is active on 14 mc. VG is back on 3.5 mc. BFI has new c.c. rig. YAL has new QRA book almost complete. HQO new call is KTF. HOO did nice relief work for yacht *Dolphin*, of which JPD is operator. Adams, new SCM, is on two months fishing trip. EDH had two "outside" visitors.

Traffic: K6EWQ 3654 KCK 331 GUA 271 GZI 164 HQO 121 FAB 108 EDH 68 CCO 63 EGE 57 FJF 18 CRU 8 HOO 28.

LOS ANGELES—SCM, Howell C. Brown, W6BPU—HZT schedules ZLIFT and VPIAM. EBK uses P.P. '03As. BMC is in Pomona for summer. ERT uses directional antenna on 14 mc. IOX schedules K6GUA. KBY got three hams to join A.R.R.L. JQS is new A.A.R.S. IIK is O.R.S. EK has beauty on ticket. ZBJ is off to Y.M.C.A. boys' camp. JWV spent week's wages on new equip. DNA has new receiver. GLZ is taking exam for commercial. DEP is working 56 and 28 mc. CV is a 'phone man and wants traffic. HDV uses 84Is final. DOK trying ten finally worked a J. JYH has worked 22 states on 1.7-mc. 'phone. KJG uses M.O.P.A. '45s. IDU worked second ZL on 3.5 mc. FET worked all continents. GIG says new Raytheon takes 140w. without blush. ON uses Collins antenna coupler. ANN has new rig on at last. KJE has new pole. BPM is going back to 'phone. ITK is building low-power c.c. rig. JBP is one of triplets. Thanks, fellows, for my election as SCM. I will do my best to keep the Section up where it belongs, if you will help. Reporters, but no traffic: CXW, BMN, IAR, COF,

BFL, KSR, CVV, KFK, EGC, DZI, ALR. Big barbecue at Ventura; present were: CVK, BDZ, KAB, BZF, BCX, KOH, DCJ, BHO, DJZ, GRL, FET, RP, CDY with YLs and OWs.

Traffic: W6HZZ 630 GXM 628 GNM 313 ETJ 299 EBK 280 BMC 246 BPU 170 IDZ 137 FIC 120 FYW 106 ERT 99 AZU 84 CGE 83 DJC-IDX 79 FGT 78 HID 72 JWY 68 KBY 64 HUG 58 AKW 55 JQS 46 ELJW 40 AM 39 CYS-IHK-FGG 37 EK-JWL-EGJ 36 BZF 32 DZR 31 ZBJ 30 FYT 30 JWV 29 EQW 23 JXZ 26 DWP-DNA-GLZ 25 DEP-JSK 23 DJS 22 KEY 21 HQS-FUS 17 FXI-GEX 13 JPN-CV-IY 12 GSR-HDV-GMA 11 KNP-IFW-HHG 10 AIX-DOK-CEM-DTE 9 HDR-KJP-HLZ-CPM 8 JYH-BGF-AGF-DYQ 7 KRT-MA-KHQ-KJG-UP-KRI-TN 6 IDU-DGH-IVU-DUX 5 IYE-IFG-BQF-KCG-VO-HCF-AAE 4 FET-IXH-KEI-AIF-GIG-FXF-BVZ-ON-FUK-ANN 3 IVL-JSZ-KJE-BPM-ITK-KBB-LC 2 KMG-RZ-FDE-JNE-HFU-AAK-BPP-JBP 1 BOB 12 ETL 1654.

SANTA CLARA VALLEY—Acting SCM, Barton A. Wood, W6DBB—AZC made W.A.C. with '10. BMW is getting 14-mc. 'phone going. CUZ worked 7 Europeans on 14 mc. YX transmitter works FB on break-in. IUZ schedules Father Hubbard expedition. DBB has 14-mc. c.c. rig. JUQ uses 3592 kc. ISW is on 1.7-mc. 'phone. JRU has an FB7A. AUC moved to Pacific Grove. FYD has '45s unity coupled. DRU is back after year in C.C.C. BCF is returning to Coronado. JSB is telephone op. in C.C.C. camp. HJF finished c.c. all band rig. HZW is scraping parts together for new 'phone rig. The "Oscillating Owls," consisting of over a dozen Santa Clara Valley hams, hold regular meetings on 1.7-mc. 'phone every Friday night. The Santa Cruz Amateur Radio Club has been reorganized.

Traffic: W6FBW 138 AZC 62 BMW 39 CUZ 26 YX 20 IUZ-DBB 14 JUQ 4 JWV-ISW 2 JRU 1.

EAST BAY—SCM, P. W. Dann, W6ZX—RJ says A.A.R.S. Hamfest at Yosemite went over big. AKB schedules K7 every evening. CIZ burned out his power transformer. EJA says Madrid Regs haven't affected traffic as far as he can see. 7BWD was a visitor at FS. KNO from Clear Lake reports. HHM is back again. IUF recently rode the goat, and 'twas a good thing his shoes were laced tight. EDR is fussing around with 'phone. VS gets out FB with pair of '46s. CTX is navigating officer of good ship U.S.N.R. GOP got ZX to change over to primary keying! FQZ is rebuilding.

Traffic: W6RJ 229 ZX 115 RF 33 AKB 34 CIZ 26 DES 21 FS 19 AF 12 KNO 9.

SAN FRANCISCO—SCM, Byron Goodman, W6CAL—ZG tops all with grand total. RH worked F8PZ for W.A.C. DDO took Class-A exam. WF rebuilt with link coupling. HSA has separate rigs on three bands. JAL and DZQ are printing HAMFLASHES during summer. HIR went to Yosemite with A.A.R.S. gang. KOV works good DX with '45. AZK is trying to squeeze another watt out of '52. KMD has been in Washington. KBM has power supply trouble. HZP needs an alarm clock. BIP works few Europeans. JQZ is awaiting 83s. JVV is rebuilding rack and panel. GZD has new c.c. rig. BCA uses grid-modulation on 3.9-mc. 'phone. COP likes link coupling. FVJ gives 28 mc. a whirl.

Traffic: W6ZG 2571 RH 316 NK 140 DDO 78 WF 38 HSA 27 JAL 26 JDG 17 HIR-KOV-AZK 16 KNH 15 GLR 14 JQV 12 KMD 11 KBM 10 BJM-HZP 9 BIP 5 JQZ 4 UI-JVV 2 GZD-BCA-COP 1 JN 23 FVJ 11.

SACRAMENTO VALLEY—SCM, George L. Woodington, W6DVE—GHP reports for Roseville. KKL (Salt Lake City) is now in Roseville. KME is Roseville call. JNB and IOB are on 3.5 mc. KQJ is on with Tri-tet. KFY is DXing. KCA is c.c. IZE is building 1.7-mc. 'phone. GHN visited GVM. IMV is building c.c. rig. EOU is playing and singing. FH and GR are on 28-mc. 'phone. GDJ blew his '52. IQH and GVM on 1.7-mc. 'phone talked for 7½ hours without a break.

Traffic: W6CGJ 31 GZY 17 DVE 8.

ARIZONA—SCM, Ernesto Mendoza, W6BJF-QC—The Cottonwood Radio Club sponsored two-day outing

—Field Day at Mingus Mt. ALU and IIG made BPL. QC had portable, on N.G. Colorado River patrol. KOL is moving to Miami. FZQ, IIG, JOW, IIF, IMR, DHR and FOH have new PR-10's. BRI works IOX daily. KFC uses 205-D's P.P. IQY lacks only Africa for W.A.C. GFK schedules DPS and KKE on portable. KBJ uses c.e. P.P. '46s. HEU went to Ohio on visit to his father. SDJW. 20A is employed at Phoenix airport. DCQ is building BC station. FFC and GZU are on 14-mc. 'phone. GYM is radio serviceman. HJX moved to Superior. KIJ and ANO work for transient camp radio at Prescott. EL at headquarters. AEK at Phoenix. HKX at Iron Springs. Ex-5ZZB-6ZZBC is now 6KIR. JIW fell off a house onto a cactus! IDR is putting 830 on air. ILL is moving to 1.75-mc. 'phone. CHR moved to Phoenix. KOA is on 1.7-mc. 'phone. KWI is new Bisbee ham. AWA and BGW were Phoenix visitors from S.F. FBE returns to Detroit, Mich., for summer. KKK and KKT are together on 3.5 mc. JRK and KQT are also working together. AND and DRE work Europe and Africa on 14 mc. Phoenix Radio Club has a special night for bridge enthusiasts each week. DKP/GDI is employed in BC station in Kentucky. JYQ is rebuilding to c.e. P.P. 211. BLP is back with nifty new outfit. KGL has 2 212-Ds for modulating final '52. GJC likes c.e. FKX sold SW5 to EBP. Phoenix Radio Club has fine door prizes since reorganization. Dues are now one dollar a year, and ten cents at each meeting for punch, prizes, etc. Meetings every other Wednesday at C. of C. Bldg., 8 p.m.

Traffic: W6ALU 1007 IIG 266 JHF 48 QC 41 KOL 31 FZQ 25 BRI-HAX 10 KFC-IQY 4 GFK 5 KBJ 1.

PHILIPPINES—SCM, Newton E. Thompson, KA1XA Annual hamfest at 1JR, Sunday, June 24th. Another Guam station is with us: OM2AA.

Traffic: KALHR 1741 NA 1493 CS 537 FS 337 EE 340 CM 167 RC 140 AN 181 XA 33. KA4GR 43. KA9WX 16. OM2AA 696.

SAN DIEGO—SCM, Harry A. Ambler, W6EOP—BMC will be on with portable. FQU is c.e. EFK worked a VK on portable with 300 volts. GTM is buying a Super. GNT works 3.5 and 7 mc. BAM worked France. BLZ left for Orient. GNP tries 14-mc. 'phone. FCT blew filter condenser. GOG and EBX went to Los Angeles to club meeting.

Traffic: W6BMC 683 FQU 169 DQN 146 EFK 110 BHF 79 FWJ 38 AXN 18 GTM 14 CNK 8 GNT 2 FCT 1.

SAN JOAQUIN VALLEY—SCM, G. H. Lavender, W6DZN—HLJ and HIP joined A.A.R.S. Work on chicken ranch keeps EXH busy. DXL is president. Stockton R.C. GQZ was QRL teaching school. GXL is saving nickles and dimes for a '52. DVI finally obtained a p.d.c. note. DZN is back on air. Now is the time to nominate your man for office of SCM. Nominations open until November 1.

Traffic: W6PYM 53 DZN 42 EXH 33 AOZ 18.

ROANOKE DIVISION

NORTH CAROLINA—SCM, G. H. Wright, Jr. W4AVT—MR's DX list is headed with J2GX! ZH worked J2HL. CGL worked F8, VP2, and G6. CCH hears plenty of DX. RV reports organization of a club in Durham. OG went to Atlantic Division Convention and the World's Fair. AAK and IF are rebuilding. BST, COK, and BRK have new transmitters. CJM has new 46 amplifier, new Collins antenna, and a new SW 3 receiver. Winston-Salem Amateur Radio Club, operating NC, portable, on top of a near-by mountain, participated in the Field Day. New stations: CYE, CYN, COC, CXI, CXR, CXG, CXC, CXS, CXL.

Traffic: W4NC 46 CJP 28 BRT 18 VB 10 CUA 10 BPL 8 BKS 6 ALK 5 BVD 5 RV 5 TJ 5 BRK 5 CCH 4 OG 4 IF 2 CVQ 2 CCF 2 AAK 1 CJM 1 CGL 1 CGY 1 COK 1 CTO 1 CUB 1 BX 1.

VIRGINIA—SCM, R. N. Eubank, W3AAJ—ANT schedules K4AA daily. ALF has 56-mc. rig. CKM is at C.C.C. Camp. FNO worked 1MK. ENJ has six operators. CA is working on convention. EEN is traveling Lt. for

U.S.N.R. EHL is now AARS. CNY is 3972-ke. c.e. 'phone. DBI is Petersburg Club Station. DZW is now ORS. AAJ spends most of his time on "Bull" and Va. work. BEK wants OPS. BRY has FB AARS Net. DCU is QRL at C.C.C. Camp, WVGH. ASK was heard in Moscow on 3.9-mc. 'phone. BIG is on 3995-ke. 'phone. FJ is Exp. with 56-mc. 'phone. OM has new location. EBD is building new receiver. DWE is back at Harrisonburg. CSI is going on 7 mc. for summer. BNX visited CM7CR, HH1A, HH1A, HH7C. BZE uses c.e. now. CFV was hit by lightning. JG uses '45s P.P. EAP wants 56-mc. reports. ERW been on month. 3700. BPI QRL work on Little. McDonald, ex-W3ARU, on 56 mc. getting ticket agn. EDG Exp. portable while traveling. GY is rebuilding 'phone. AUG is QRL tennis. UVA is back from West Coast trip. IQ is Pres. Peninsula Club. CFL is back from Ohio State U. CMJ is at C.C.C. Camp, Petersburg. BZ is rebuilding for 1.7-mc. 'phone. AKN is trustee for club station. AIJ is on 1.7-mc. 'phone and 3.5-mc. c.w. BAD is trying Tri-tet. EGD uses c.w. on 7 and 3.5 mc. EJK is home from U. of Md. DGT, ELJ and ELA are rebuilding. EMX will have 59 Tri-tet soon. CXM is going to P. I. in August. Luck, BN! AVU has two rigs on 3.5 mc. at Scout camp. BNH is chief op. of Richmond police rig. WO's QRA is E.A.T., Balto. Anyone in Va. having any equipment for freqs. above 14,400, pse put on report card. DSH now with BC stn. WMBG, QN and OM go to all hamfests in Va. NORFOLK—VA. BEACH HAMFEST IN AUGUST! FLEET WILL BE IN! Special mention goes to Official Phones GY-BIG-CNY for taking first three places in last O.P.S. Contest. Have you any equipment that will operate from Batts in Emergency? Put on card or write card to A.R.R.L. EX-ARU is on 56 mc. EDG uses portable while traveling. ERW is active.

Traffic: W3ANT 96 BWA 76 ALF 31 CKM 22 ECQ 27 ENO 20 ENJ 18 CA 17 EEN 15 EEL 9 CNY 8 DBI 7 DZW 6 AAJ 5 AAF 5 BEK 3 BRY 7 DCU 45 ASK 4 APU 2 BIG 5 FJ 53 OM 27 EBD 24 DWE 12 CSI 8 BNX 4 WM 4 BZE 3 ELB 3 CFV 2 JG 2 CZX 2 COO 1 EAP 1 EBK 16 EOX 4.

WEST VIRGINIA—SCM, C. S. Hoffmann, Jr. W8HD—DPO is first in state to make a WAC! FB, OM. KSJ has new '03A P.P. c.e. job. HWT joins WV Net. HCL uses '52s P.P. HGC moves to Youngstown. BOW and FQB BTV are home on vacations. CSF locates in Wheeling. W8ELJ works as NCS on "WV" Net. 8EIK/WLHG works as Army NCS on 3497.5 kc. on WLM's schedules. EWM is building set for JQP. New stations: Bluefield MCL, Yukon MCR, Weston MCJ. LUX works all U.S. on 3.5 mc. BDD, AKQ, CVX, KGT, and HBB rebuilding. DMU and OW, and KJL visited ASI. CBS sold out; CHM has new all-band portable. HIU, BIK, CHM entered Second Annual ARRL Field Day Contest. KKG (RM) attended Clarksburg Hamfest. GDF won 56-mc. transmitter at Hamfest. AVC of Zanesville, Ohio, was in Clarksburg. AMX operates Clarksburg Police Station. New officers, Mountaineer Amateur Radio Assn. (Fairmont): JWJ, Pres.; KGT, V.-Pres.; Bob Pell, Secy.; JM, Traffic Mgr. Clarksburg hams worked ex-8IB (from 6HMW), who is on his way to British Columbia to live. KWU bought big set from TI. ASI is using 'phone; IXT on 3886 c.e. CMJ has new RME receiver. LSK worked 55 stations with 10 watts on 7 mc. LSJ worked 4 districts on 3.5 mc. AEF was appointed 'phone station Route Manager.

Traffic: W8DPO 14 HTW 17 HCL 17 BOW 17 HD 12 EIK 527 LUX 27 BDD 84 DAM 3 KKG 163 KWU 3 DFC 2 ASI 13 LSJ 2.

ROCKY MOUNTAIN DIVISION

UTAH-WYOMING—SCM, Arty W. Clark, W6GQC-IDM—6FRN solicits aid of stork for new Jr. op. BSE keeps air hot between Camp Williams and S.L.C. KDI wants to DX S.L.C. GPJ wrecked his car. FPJ and GQU were on negative side of Utah State Championship Debating Team. AFN built portable transmitter. ITW is building c.e. rig. JYD has new Tri-tet. KOP has key click trouble. FYR reports from Nevada. KGM has pair '46s final. EYS announces arrival of new YL op.

DGR is QRL building at NDO. BTX is in Yellowstone Park for summer.

WYOMING: W7AEC reports his OW licensed with call ELU. Congrats. CLG is equipped for portable operation. CYZ built c.c. rig. DIE and W2EVV among those who visited S.L.C. hams. FB hamfest of Wyoming hams at Thermopolis. Utah A.R.C. Hamfest at Como Springs successful in spite of rain. Fifty-five present. Their pleasure was to have the presence of Director Andrews, 9AAB, and Mrs. Andrews. Out of state hams were 3CXF, 7DIE, 7COO and 7BZZ. Don't forget W1MU at Jenny Lake on Aug. 4th, 5th, and 6th.

Traffic: W6FRN 712 EXL 208 BSE 166 KDI 47 GQR 18 HVU 10 GPJ 9 FPJ 7 AFN 5 ITW 2 GQC 365. W7COH 61 AMU 43 CSE 22 AEC 1 COO 1.

COLORADO—SCM, T. R. Becker, W9BTO—ESA is on vacation; GNK reports a nice total. IFD has an 800 tube. NIT worked a VP with 14 watts input. JFD gets good reports with impedance matching. W5DVU is a brother of W9NIT. W9G3Q is still pounding them out. EHC has been active in field experiments. FXQ is on at Cragmor. JNV continues to improve in health FB OM. YL left for the University Camp. PGS worked a ZL es TI, VP, NY wid 210 Hartley. JRV left for Chicago. AZT won a 210 at the Hamfest. FYK is back from Calif. PWU has 5 Transmitters. CSR is working in Washington, D. C. GLI is CC now. The R.F.A.R.A. had a picnic June 3rd. IPH had his large bottle go soft. BYK is having trouble with his oscillator. DDF is putting in new 50-watt rig. BTO will have separate transmitters on all bands. BYY is going Fone. CJJ plans some 5-meter work. LYE is working for Remler. EMU is overhauling his speech and receiver. FYY is back to his 50 watter. HRI has fully recovered from his accident. CBU is planning to be on soon. BJN is reported better after a short illness. FA is on now and then. GNV is on a Navy cruise. Joe Roher is working at KOA. AAB is having trouble with his back again. 5-meter activity seems to have acquired a large amount of interest here. Well, fellows, that's about all for this month as the summer QRN seems to have taken command of the Radio activities. Here's hoping that the activity increases next month: CDE is active at his QRA.

Traffic: W9ESA 953 GNK 138 GJQ 731 EHC 88 PGS 8 JRV 1 GLI 75.

SOUTHEASTERN DIVISION

ALABAMA—SCM, L. D. Elwell, W4KP—DS, chief ARM, leads traffic gang. APU, RM for north Ala., worked some 14-mc. DX. BJA holds up his end of state. AJY works plenty of DX. ATD is active with new rig. ADL is pounding on 3.5 mc. AWQ has new 7-mc. rig. AXU has increased power in the 'phone and gets out FB. BMM, the 'Phone RM, is doing FB work. CUE, B'ham Club station, works fine. KP is headed for 14 mc. BGO returned from school. BMF is QRL U.S.N.R.

Traffic: W4DS 65 APU 42 BJA 29 KP 6.

EASTERN FLORIDA—SCM, Ray Atkinson, W4NN—The Central Florida Radio Club sure knows how to put on a convention! Over 100 hams attended at Orlando. The work of Captain Cole and tireless effort of Convention Committee is to be commended. BNI, now on 3.9-mc. 'phone, has new PR-10. BIN is on 7 and 3.5 mc. CWV is new ham at Haines City. BDQ and BZN are on 3.5 mc. BWZ is building new receiver. BUM will work portable in ninth district this summer. 9HIU is now in Miami. APY will be located at Asheville, N. C., this summer. AZB has fifteen stitches in head from speedboat accident. WS has code class of five youngsters.

Traffic: W4WS 40 NN 26 ASR 3 BNI 1.

WESTERN FLORIDA—SCM, Edward J. Collins, W4MS—RMS: 4AUW, ACB. The hamfest at Tallahassee went off in great style. The West Fla. Shortwave Club was reorganized under name of "Suwanee Transmitters Association." CUR is putting a wallop all over country. CTZ holds things down with CLP in Perry. BGA joined U.S.N.R. BFD plans new receiver. QK was heard in Hungary. QU received U.S.N.R. commission.

COG handles Gulf Coast Storm Net schedules over MS. CWF is newcomer in DeFuniak. BJS is our fourth W.A.C. AUA is getting rig in shape. ACB wants an FB7A. KB is getting set for his hamfest. AQY is with the State Highway Dept. CTA is on in Pensacola. CMJ was on vacation. COG has new a.c. Super-Wasp. MS is visiting 9USA. ASV has M.O.P.A. AUW is getting up some traffic lanes; let him know your operating hours. CRU swears by Comet Pro. Reports received from: BKD, BOW, CMB, AQA, ABK. 5ZZR-4BSV was visitor to Pensacola gang. CDE bags DX. CBD wants to sell out.

Traffic: W4MS 27, KB 53, COG 11, BFD 6, VR 14, BGA 10, QK 4, QU 1, CTA 3, CTZ 2, ACB 12 AUW 10, CDE 18.

SOUTH CAROLINA—Assistant SCM, Bannie Stewart, W4CE—CQQ is on 3.9-mc. 'phone. CPZ is on 14-mc. c.c. BNN is building suppressor grid transmitter of May QST. BCN is back on from Clio, S. C. MN teaches Radio at U. of S. C. BZX finds 1.7-mc. 'phone holding up well. BJC is back from Clemson College. CUS and CZA are new in Charleston, S. C. OW plans medium-power 'phone. HN, an old-timer, is located in Charleston. AFQ was married recently. CE was on cruise up north with Naval Reserve. All South Carolina amateurs please send a report to 4CE, by the 20th of each month.

Traffic: 4CE 6.

WEST GULF DIVISION

NORTHERN TEXAS—SCM, G. E. Talbutt, W5AUL—ZD is honor traffic man. ARS is still doing the family washing. BKH has a "swell shack." AOD and 6DGT are getting ready for a big traffic season, at Lubbock. BTJ is "Granpop"! DAA reports CZZ, CAE, CYJ, active. EFC and EEF are new hams in Clarendon. EFO reports for first time. DSA is with C.C.C. at Dublin. COK takes rig to Chicago for the summer. BCW reports 4BKS has moved to Olney. IA is saving up for Chi-Fair. NW and DUR attended the "big brawl" at Tulsa. DXA is a "vocal cinema" op. DMA is Mayor, J. P., R. R. Agent, leading Ham and Gangster in his City. AUJ joined the T.N.G. BAY says his Tri-tet portable is the berries. The Abilene and San Angelo Clubs held their annual spring hamfest at Buffalo Gap.

Traffic: W5ZD 174 BII 159 CPB 92 AW 82 ARS 69 GLJ 32 BKH 31 CPT 30 AOD 26 BTJ 10 DAA 11 CXS 9 ARV 8 EFC 1 EEF 7.

OKLAHOMA—SCM, Carter L. Simpson, W5CEZ—CEZ installed plug-in inductances. BZQ is new RM. CON is going to spend the summer in Calif. AMT makes application for A.A.R.S. AYF was QRL preparing for Convention in Tulsa. CRS is new O.B.S. COA is new O.R.S. DDW is a disabled World War Veteran. AA has new crystal for 3.9-mc. 'phone. The Section suffered a great loss in the death of Edward H. Degroot III, 5AMC of Oklahoma City. The Semi-annual Joint State Convention was held in Tulsa, June 16th and 17th. The next meeting in this series, which are jointly sponsored by the Tulsa Amateur Radio Club and the Ponca City Key Clickers Club, will be held in Ponca during the latter part of January. AIR is new O.O. The amateurs of Okmulgee have organized a club, The Mike and Key Club.

Traffic: W5CEZ 599 BQZ 90 CON 78 AMT 36 BAR 27 DTC 23 AYF 24 ASQ 22 CRS 11 COA 6 CJZ 6 BWN 7 DDW 6 AA 5 BDX 7.

SOUTHERN TEXAS—SCM, D. H. Calk, W5BHO—MN keeps eight regular schedules. BJ is rebuilding Final to 211. ADZ made W.A.C. 8GDF holds four schedules daily on 3.5-mc. 'phone. DPX is rebuilding to c.c. BVG enlisted in U. S. Army Air Corps, Kelly Field. MS visited Chi. Fair. HP has new receiver. AQK is attending radio school, Austin. W5APM and W5CNO visited with MS. CCD is building c.c. rig. CPA is building 56-mc. transmitter. DTB has FB new c.c. rig. DSI works VKs. The Houston Amateur Radio Club held its annual Bar-B-Q, May 27th, at the San Jacinto Battle

Grounds. DPX is new 'Phone Activities Manager. BFA is new O.R.S. The Gulf Coast Storm Net has enrolled several new members. Your SCM visited the San Antonio Radio Club June 15th.

Traffic: W5OW 1051 MN 251 BXX 98 BJ 31 BEF 16 ADZ 21 8GDF 25 5DPX 2.

NEW MEXICO—SCM, Dan W. DeLay, W5DUI—CJP is new reporter from Santa Fe. Portable DYV in Boy Scout camp schedules CJP. DLG is prospective OBS.

Traffic: W5DUI 69 ZM 34 CJP 17 DLG 7 EAO 7 AAX 3 DSN 3 AUQ 1.

CANADA

MARITIME DIVISION

NOVA SCOTIA—SCM, A. M. Corwell, VE1DQ—EP made first contact with K6. HG has worked 14 countries. FT is c.c. on 14, 7, and 3.5 mc. GL is QRX daily 6 to 7 p.m. for traffic. DC spent vacation in Halifax. ET has job with Can. Marconi Co. at coast station. AG works 3.9-mc. 'phone mornings and evenings. BO entertained bunch of hams on vacation. CL had visit from W1AQB and friends. GN's 1.75-mc. 'phone works FB. DQ expects to have 56-mc. transceiver shortly. DE landed new job in Montreal. GR gets out well with 1.75-mc. 'phone. EI is back on 3.9 mc. FB wants more of the gang to cooperate and send in envelopes for their QSLs.

Traffic: VE1FT 4 GL 18.

ONTARIO DIVISION

ONTARIO—SCM, S. B. Trainer, Jr., VE3GT—JT is new RM for Toronto. RK has gone to camp. LI also, taking a portable with them. SG will have his hands full with City Hall Centennial traffic. 9AL will have his portable, 3AL, going at Stoney Lake. MX is in Kingston for summer. JI visited W8AAL and 8KIR. MB is new ORS. VD is redecorating. GH is setting up 14-mc. 'phone. NJ has a.c. power now. DU and LW, PA, QC, WW, VR, and KC operated KC in portable contest, working 70 stations in terrific QRN. GT and JT were out, too, but were washed out with thunderstorm. PN will soon be on 'phone. YY reports activities on 28 mc. It is with reluctance that I report HP has resigned as RM and ORS. QB is saving for new set of B Batteries. AZ, GR, GT, SG, JT, M3, UY, JO, IB and CN are working on Convention plans for Oct. 5th and 6th.

Traffic: VE3JT 213 VD 9 GT 49 MB 17 RK 133 JI 22 MX 27 DW 1 NO 30 YS 5 WK 35 SG 57 QB 24. VE9AL 34.

QUEBEC DIVISION

QUEBEC—J. A. Robertson, VE2GA—We had a short but enjoyable visit from Mr. A. Hebert of Headquarters. He gave a splendid talk on Headquarters organization before an informal gathering at Payettes. Under auspices of Montreal A.R.C. we had a glorious picnic at La-chute on Sunday, June 3rd. More than 100 hams, YLs, XYLs and offsprings attended. Daddy Dawes, BB, won the 80-meter race, and BE and BG won the three-legged race. Our past-SCM took an individual photo of everyone present. HG is taking transmitter to country. AR and DU looked after amateur radio installation at Canadian Electric Convention at Lucerne, Que. GO and HK kept schedules with Lucerne and cleared lots of traffic. CX is busy at steamship office. Welcome, IT at Beaupre. GE works Africa with '10s. BK strives for VKs and ZLs. DQ sailed for England. CL operates station for Forestry Protection Society in Northern Quebec. DU has feeders inside chimney. EC is active on 3.5 mc. RG worked two G's in his old home town. CA scheduled G5YH relaying birthday greetings to HRH Prince of Wales. IU is a new reporter. AI considers single signal. DH is building new 'phone. FZ is on 1.7-mc. 'phone. HP works DX with low power. AC works 28 mc. Saturdays and Sundays. BB

works Switzerland. EE has visit from G600. EK is pending O.P.S. BE and CA visited SCM. Nice letters from FL, DU, EC, CO, CU, DG, GN, Thoms, OMs.

Traffic: VE2II 28 AP 11 GO 24 EE 14 CO 5 AC 48 DG 26 BB 36 CA 3 BG 27 GA 2 HK 157 CG 26 EC 13 CU 1 DR 4 BU 23 BT 6

VANALTA DIVISION

ALBERTA—SCM, J. Smalley, Jr., VE4GD—BZ attended Lethbridge Hamfest. KG keeps Calgary on traffic map. GD attended Spokane hamfest with AX, AW, NH and GK. LX has daily schedule with K6FAB. LK worked first Aussie ever called. PH built emergency transmitter. LG, RU and SD are new Edmonton hams. LQ is now c.c. EW is building new rig. EA's DX looks like list of calls heard. FR likes 14 mc. HM hooked ON, G, and VK in 30 minutes. EX plans trip to Portland, Aug. 1st. Lethbridge Hamfest was huge success, with GA and EU long-distance visitors. GM slipped to 14 mc. FG working at Lake Louise for summer. HC and ExCA visited JP. HQ, CY and FI like 14-mc. 'phone. EO captured first prize in Lethbridge Club Contest, BZ second and JR third. HW works plenty DX.

Traffic: VE4BZ 73 KG 34 AF 39 GD 8 LX 25 LK 6 QX 2 HM 7.

BRITISH COLUMBIA—SCM, R. K. Town, VE5AC—EC is putting in 250 watter. DO visited the SCM. HP is QRL commercial operating. EP wants schedules. GI moved to Bridge River. IO, EJ and JI attended Spokane Hamfest. FM is a constant rebuilder. JK plans more power on 1.7-mc. 'phone. GH, a newcomer, plans c.c. EI's 3.9-mc. 'phone was heard in Palestine. GZ is first-aid man and mechanic at Bralorne mine. HU takes to c.c. with tens. IQ and FU are newcomers. IH is on vacation. JO has c.c. BE makes good on 3.5 mc. AT is operating for Bedaux expedition. GT handled emergency traffic for a forced-down plane. KN has nice 1.7-mc. 'phone.

Traffic: VE5DO 6 HP 54 IM 84 EP 20 JA 28 AC 79 GI 74 IO 29 EJ 18 FM 10 JK 20 GS-EE 2 DF 41 DZ 2 KC 4 GT 24 KN 6.

PRAIRIE DIVISION

MANITOBA—SCM, Reg Strong, VE4GC—DK is operating commercial up north. Winners in M.W.E.A. local QSO contest: DZ, AG, MV and KU. BG has kilowatt input. DJ tried 14 mc. AE dismantled Collins coupling unit. GQ is building 250-watt stage. NW would like a Patterson receiver. KX has modulation troubles. KU nearly lost antenna. FP checks overmodulation. GC has '52 in final. CP is looking for good receiver. DU made W.A.C. LB schedules GR. CD is on 56 mc. FU is on 'phone. IT has c.c. rig. CI left for the west. QA uses 7-mc. crystal in Tri-tet. OB and TJ are on 28 mc. DF is going c.c. NT went to Gimli. RO is looking for a pair of '66s. EK moved to 14 mc. NP built new receiver. SB is experimenting with crystals. IP is on 14 mc. 'phone. HZ popped a pair of tens.

Traffic: VE4LB 27 KU 25 GC 19 AG 9 NI 7 RO 2.

SASKATCHEWAN—SCM, Wilfred Skaife, VE4EL—Moose Jaw staged an A1 Hamfest with 71 attending. MH is building XMOPA with his prize '81s in power pack. LZ and MH are trying portable 56 and 28-mc. work. ON burnt out M.G. GN gets great DX with a '45. BF spent nice holiday at Watrous and made lots of QSOs. JH worked ten VKs and one G. EH is working on 'phone. PM keeps daily schedule with Winnipeg and Edmonton. ND works Saskatoon and Lethbridge daily. EL visited Swift Current and had nice QSOs over CV and ND, also nice chat with CB on return trip.

Traffic: VE4GR 77 EH 58 MH 38 EL 15 PM-QK 13.

LATE AND ADDITIONAL REPORTS

VE1FR was licensed June 10, 1926; is now working 3.5 mc. 9MXXL, MZP, PEW and Ex-9JNF attended 9PAK's wedding. 9MXXL was best man. 8KZO is going strong with DX on 14 mc. 8HGF has new rig. 8EQC is going FB. SOG and GGU are rebuilding.

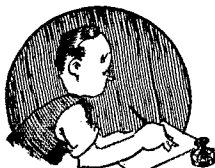

CORRESPONDENCE

The Publishers of *QST* assume no responsibility for statements made herein by correspondents

Greetings from the French Amateurs

Réseau des Émetteurs Français,
17 rue Mayet, Paris

Dear Colleagues:

On the occasion of the twentieth anniversary of the founding of your association, we are happy to send you all our best wishes for your future success.

As the oldest section of the International Amateur Radio Union, next to the A.R.R.L., we hope that the splendid relations existing between our two groups will be continued as they have in the past.

Believe, dear colleagues, in our most friendly wishes, and all our 73.

For the council:

A. Auger, F8EF, President, R. E. F.

More Birthday Wishes

Berlin, Germany, June 9th, D4BUF via W1HIU
A.R.R.L.

WESTHARTFORD

THE HEARTIEST AND CORDIAL CONGRATULATIONS TO THE TWENTY YEARS JUBILEE OF YOUR MIGHTY ORGANIZATION.

DEUTSCHER AMATEUR SENDE-UND-EMPFANGS DIENST

Should Maximum Power Be Reduced?

Staten Island Amateur Radio Association,
Staten Island, New York

Editor, *QST*:

This communication from the Staten Island Amateur Radio Association is a proposal which we offer for serious consideration by the League and which we believe will materially help in minimizing the ever-increasing congestion in the amateur bands, both 'phone and c.w. It is proposed that "the Federal Radio Commission limit the power input of all amateur stations, 'phone or c.w., to a maximum value of 100 watts."

The present power input limitation is 1 kw. This limitation has existed since amateur stations were first licensed (15 years ago), and appears to be a heritage of the old spark days. In the old spark days there were not the number of

stations there are to-day, furthermore 1 kw. was required to obtain any fair distance. With present-day receivers a transmitter with 5 watts input to the last stage can accomplish with equal consistency the same results as the 1 kw. spark.

Congestion in our bands is becoming serious, and more so because of the ever increasing number of potential hams contemplating putting transmitters on the air. We have spread the bands with crystal-filter receiving equipment to avoid the effect of crowding that has developed from the increasing number of hams that have come to the bands already. Having overcome to a large extent the effect of crowding, we are now facing the problem developing from the increasing number of hams who are resorting to high power to force their signals through. The result of this is that many of the hams are striving to obtain adequate high-power equipment with limited funds so that they may have an even chance with high-power ham. If this practice continues it would mean gradual development of all stations to high power (aggravating an already bad condition). There still will be many hams who would not care to resort to high power or who could not afford to purchase such equipment; they will eventually have to give up the game.

It is our contention that very successful communications can be maintained over the same distances, and greater distances, with even better consistency, if *all* stations limited their power input to 100 watts. In this way every station owner would concentrate his attention on perfecting his transmitting and receiving equipment, and every one would have an even chance.

The Staten Island Amateur Radio Association is 100% behind this movement. We are now counseling other hams throughout the States (over the air) on this matter, and it is hoped that through this means, together with the assistance of the A.R.R.L., we may have the Federal Radio Commission alter the maximum power limitation to 100 watts.

We shall be glad to offer whatever cooperation we may to the League in fostering this matter.

William C. Csak, President, S. I. A. R. A.

Morse

Sioux City, Iowa

Editor, *QST*:

In submitting the letter, which appeared under the caption "Copying Behind" in the March



This month we are writing from Los Angeles after having been away from the shop for nearly a month. On the way out we visited several ham-fests, many amateur stations and most of the supply houses. To me it certainly has been a real pleasure to meet some of the fellows that we have so often worked or heard over the air: W8CPC, W8CNZ, W8AWK, W8DFH, W9AA, W9IVD, W9CP, W9IJ, W9KB, W9MTC, W9LIP, W9PRR, W9DRD, W4AG, W5AFX, W5RJ, W6CNE, W6GWX, W6CGQ, W6JJU, W6PT, W6ELR, and many many others as well as to renew such old acquaintances as: W8BAH, W8BIT, W9UZ, W9RA, W9DCX, W9LD, W9CK, W9EFH, W9EL, W6EZ, W6LA, W6FBI, W6GWY, etc., etc.

We have with us the 100-watt "all-band" transmitter with the RK-20's that was mentioned on this page the month before last. Although it still weighs the same two-hundred pounds, it has been made "portable" by the addition of a pair of handles. All this week we have had it set up on the twenty-meter phone band at the shack of W6GWX in South Pasadena and are now looking forward to dropping down to the ten-meter band to-morrow for the regular Sunday morning schedule.

With the mountain-top locations and ungodly high masts that these W6's of Southern California seem to have in such abundance, we have high hopes of QSOing with W1SZ, W1KH, W4KR, W4TW, W4AJX, W2TP, W1CTW, — or some of the other East Coast ten-meter outfits in spite of our modest one hundred watts.

Incidentally, the West Coast hams not only have "locations" and rotatable directional antennae (W6CNE), but they consider it a gross misuse of good equipment if a pair of 852's is run at anything less than 999 FRC watts! — or for that matter, a single 852 if a pair is not available!

One of the most frequently asked questions — aside, of course, from data on the transmitter — is about our plans for a new receiver. It seems that many of the fellows have heard of the new model we have been trying to work on quietly during the past six months and have the opinion that it is being designed to replace the FB7A and the FBXA. This is not so. The new receiver is intended to fill the existing gap between the FB7 and the AGS in both price and performance. It is intended as a strictly amateur receiver incorporating as far as possible all of those features which we believe to be desirable for amateur band operation. It will have a two-stage pre-selector; use a radically new type SFL gang condenser with precision pre-loaded worm drive tuning; a new dial; a separate built-in vacuum tube voltmeter for direct reading of carrier intensities; a Lamb-type Single Signal crystal filter with full front-of-panel control and calibrated plug-in coils ganged for easy handling. As the advertising men say, "It will bristle with new features." Obviously this means it has been necessary to design this new receiver without the restrictions as to cost which were given so much consideration in the case of the FB series. We will tell you more about it later, but present indications are that the list price will be slightly over two hundred dollars and that production sets will be available in September.

We feel that the FB7A or XA in its present form is a darn good set and one that will not be outclassed by anything selling at anywhere near the same price for a long time to come. Of course minor changes and improvements will be made from time to time in order to keep it in step with the progress of the art, just as was done with the SW3. We do not now, however, know of any new developments or existing faults that would justify a new model for the coming season.

JAMES MILLEN



BY ALL MEANS COMPARE

these transceivers with any others —
you be the judge



REALLY PORTABLE TRANSCEIVERS with battery space in same case

This feature will be appreciated by anyone doing serious 5 meter work in the field.

**SOLD AT PRICES YOU WOULD LIKE TO PAY
BUT NOT BUILT DOWN TO THOSE PRICES**

NATICO transceivers can be supplied in three models, all of which have the same outward appearance.

Type TR-1: Battery Model \$10.95 (less tubes and batteries)

This NATICO 5 meter transceiver is strictly portable, allowing two way communication even when being carried. This is accomplished by the fact that the two dry cells and 90 to 135 volt B battery are self contained in the one case. TUBES REQUIRED: One 30 and One 33

Type TR-2: Mobile Model \$11.95 (less tubes, battery or eliminator)

Specially designed for automobile use or wherever a 6 volt battery is available. The case has sufficient space to hold the 135 to 180 volts of B battery or a 6 volt B Eliminator which eliminates the necessity of all B batteries. TUBES REQUIRED: One 76 and One 41

Type TR-3: A.C. Model \$16.95 (including power supply, less tubes)

Here you have a portable A.C. transceiver which includes power supply in the same case (size only 6 1/2" x 7 3/4" x 12 3/4"). It can be operated anywhere that 110 volt A.C. is available. TUBES REQUIRED: One 76, One 41 and One 80.

ACCESSORIES:

Matched Kits of National Union Tubes for —

TR-1	\$ 1.95
TR-2	1.75
TR-3	2.15
6 VOLT B Eliminator for TR-2	11.50
Hygrade very high gain hand mike with battery switch, special	5.50

Natico's Exclusive Distributors:

GROSS RADIO INC.
51 VESEY ST. NEW YORK CITY

issue of *QST*, along with my copy of the Navy Day message, it was not my intention that it be published. My reasons for this I shall try and clarify below.

Coming to the radio game from the newspaper and telegraph business I brought along, among my various other eccentricities, the hobby of practical psychology and as students of this fascinating study are prone to do, applied it to the personnel of ham radio. I noticed almost at once a remarkable difference; not alone in operating procedure, mannerisms and definite expressions of individuality, but in associations both over the air and in personal contacts, the wide variation between the Morse radio operator and the orthodox radio ham.

Just what this difference is I have never quite placed my finger upon it. One thing I am certain of is this: When an average amateur contacts a station over the air, and in the course of the QSO discovers the recipient of his signals is a Morse operator, he "tightens" up. His defense mechanism asserts itself. He unconsciously puts up his guard, believing perhaps that "this Morse operator" will "open" up on him! Does that sound absurd? If it does it is only the more convincing to me.

In the scarcer radical cases, and fortunately so for the Morse brethren, there is the amateur type that resents the Morse "intrusion" or "invasion," feeling no doubt that the Morse man has had an "inside track" to obtaining a license and is therefore something akin to a politician who, with the intellect of a moron, receives a stipend from the civic government the size of a bank president.

I do not wish to infer that such feelings are by any means representative of ham tactics, far from it, but it has occurred often enough to cause comment by those affected. No Morse operator I ever heard of ever "bit" anyone, and as a rule when he contacts a beginner is even quicker to QRS than the amateur who forgets the hard path the code learner must traverse.

I say the amateur forgets the hard "row of stumps," for it is doubtful if he sets off on his career as a radio ham with quite the determination that once marked the "manufacture of Morse lids." After serving an apprenticeship at either lugging heavy freight around the local depot, or plowing through muddy streets on a bicycle, he spent his spare time "boning up" on Morse. A period of from six months to a year were usually spent like this. Then followed a series of disappointing events in which the "lid" tried many places before finding his first "sine." So it is with more than the usual understanding that the Morse operator treats the beginner for he himself has "been through the mill."

It is rumored of Bobby Jones that when he is playing a friendly round of golf with players that play a much poorer game, that he never fails to complement the dub when he does happen to hit a clean crisp stroke. Which should show us that no matter how "hot" we may get at this code slinging racket, we're still in the game for the enjoy-



Hoyt Antenna Meter

Hot wire antenna meters, 2 1/4" mounting hole, flange 3" diameter, supplied in 1 1/2, 3 and 5 ampere ranges. Why work without antenna meters when you can buy them at this special price?.....\$2.95

Hoyt Milliammeters and Voltmeters

Perfectly damped meters at a price. These are not to be confused with the usual inexpensive meters. 2" mounting hole, flange 2 1/4" diameter, supplied in the following sizes: 10 ma, 25 ma, 50 ma, 100 ma, 150 ma, 250 ma, 300 ma, 4 V. AC, 10 V. AC, 15 V. AC, 10 V. DC. Price each \$1.30, 3 for \$3.60.

EXTRA SPECIAL!!

866 tubes that carry our full guarantee — ISOLANTITE top — Heavy duty rectifiers.....\$1.45

GUARANTEED TUBES

Gross 210 Thoriated filament.....\$1.59
59's......98
888 or 871 Isolantite top......95
83's, 47's, 46's......70
81's......80
1/4, 1/2 and 1 watt Neon Bulbs......35

RAYTHEON RK-20

The New RF Pentode Power Amplifier Tube in stock.....\$15.00
(see page 14 June QST)

SPECIAL TUBES!!

CARBON PLATE 203-A.....\$8.75

HIGH QUALITY CASED COND.

2 mfd 2000 V. working.....\$3.95
2 mfd 1000 V. working..... 2.10

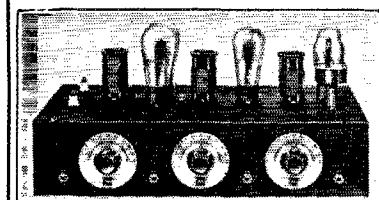

GROSS C C TRANSMITTER — OUTPUT 25-30 WATTS

The "CW-25" transmitter kit due to its low cost makes it possible for anyone to own a modern crystal controlled station. A schematic hook-up and parts layout sheet as well as tuning instructions are furnished, thus enabling the most inexperienced operator to wire and put the set on the air, for real results. The "CW-25" is supplied with a shrivel finished sturdy metal chassis under which all parts are mounted, making the wiring and components dustproof. A plug-in crystal holder is furnished with the kit. Only one milliammeter is required for tuning the transmitter and each stage is provided with a jack for this purpose. The "CW-25" uses one '47 as crystal oscillator, one '46 as buffer or doubler

and two '46's in the amplifier stage, set of three coils supplied with kit for 20, 40, 80 or 160 band. **\$13.95**
Additional coils 75c each. Complete kit, less tubes and crystal.....

GROSS SPECIAL TRANSFORMER

600 volts each side of C.T. 200 MA
2 1/2 V. 10 amps., 5 V. 3 amps.,
7 1/2 V. 3 amps.....\$3.39

Cased Combination Filament Transformer

2 1/2 V. C.T. 10 amps for 866's
10 V. C.T. 7 amps for '50's or '52's
10000 volts insulation.....\$3.24

FILAMENT TRANSFORMER FOR BRIDGE RECTIFIER

using 83 tubes 5 v-5 v-5 at 3 amps
C.T. — 3000 v insulation.....\$2.25

CLASS B TRANSF. — 19 TUBES per pair.....\$3.00

THORD. 15 H 250 MA choke.....\$2.95
GROSS 30 H 200 MA cased choke... 1.94
Cased 30 H 125 MA choke......95

MIDGET DOUBLE SPACED NEUTRALIZING CONDENSERS

35 mmf. — a real buy.....\$5.99
Pilot J-23 100 mmf. condensers......55

Ward Leonard Vitreous Resistors

8 1/2" long with variable sliders — will dissipate 200 watts.
1000 ohms.....\$.99
2500 ohms..... 1.05
5000 ohms..... 1.05
10000 ohms..... 1.11
15000 ohms..... 1.20
25000 ohms..... 1.29
35000 ohms..... 1.35
50000 ohms..... 1.44
60000 ohms..... 1.49
80000 ohms..... 1.59
100000 ohms..... 1.65

Mounted Center Tapped Filament Transformers

2 1/2 v 8 a — 2 1/2 v 3 a — 5 v 3 a.....\$1.29
2 1/2 v 4 a — 7 1/2 v 2 1/2 a — 7 1/2 v 2 1/2 a.....\$1.29
2 1/2 v 4 a — 5 v 3 a — 7 1/2 v 2 1/2 a..... 1.29
5 v 3 a — 7 1/2 v 2 1/2 a — 7 1/2 v 2 1/2 a..... 1.29
2 1/2 v 6 a — CT (midget)......74
5 v 3 a — CT (midget)......74
6.3 v 1.5 a — CT (midget)......69
7 1/2 v 3 a — CT (midget)......89

NEW!!

Gross Crystal Holder

WHITE CERAMIC commercial type crystal holder — priced at less than ordinary holders. Adjustable pressure, dust proof, no tools required to open. Takes crystal to 1 1/4" square. Plugs standard 3/4" spacing. **\$1.00**
Most excellent job yet.....

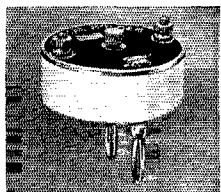

Universal Antenna Coupling System Inductances

Wound on threaded double X natural bakelite tubing, can easily be tapped, with clip supplied, ea.....\$1.75
(Use one coil for single-wire feed and two coils for two-wire systems)

Universal Antenna Tuning Unit

Complete kit of parts for outputs up to 50 watts.....\$13.95

Low C 40-80-160 Meter Amplifier Coils

(See transmitter by GRAMMER page 46 May QST) Plug-in, wound on threaded natural bakelite tubing, will tune with 50 or 75 mmf. condenser any size, each.....\$2.00

Hard Drawn Tinned Copper Antenna Wire

No. 12 (any length) per 100 ft.....\$55
No. 14 (any length) per 100 ft......35

GROSS CASED POWER TRANSFORMERS

650 v ea. side C.T. 350 ma fila. 2-7 1/2 v C.T. and 1-5 v will give 500 v with choke input using 83 or 5Z3 tubes. You can run your entire R.F. and class B off this trans.....\$5.50
750 v ea. side C.T. 300 ma fila. 2-7 1/2 v C.T. and 1-5 v.....\$5.75
750-1000 v ea. side of C.T. 300 watts, \$6.65
850-1350-1500 v ea. side of C.T. 400 watts.....\$8.70
(the ideal job to give 750-1000-1250 v D.C. with choke input)
850-1350-1500 v ea. side of C.T. 550 ma.....\$12.50
1500-2000 v ea. side of C.T. 800 watts \$11.70

Filament Transformers shielded in metal cases, center tapped secondaries

2.5 Volt 10 amperes for 866's.....\$2.25
10 to 12 Volts at 8 amperes..... 2.25
Special 10-12 Volt 7.5 ampere filament transformer, extra special.....\$1.10

The "EAGLE" Three-Tube Short Wave Receiver

"Band Spread" over any portion of the tuning range — only finest material used thruout. Employs one '32 R.F., one '32 detector and one '33 Pentode Audio — 15 to 200 meters — four coils, supplied. The "EAGLE" is economical — two dry cells will operate the filaments. See March or April 1933 QST for full description of this most excellent value in short wave receivers.

"Eagle" completely wired and tested. **\$11.95** Three tubes tested in your receiver.. **\$3.00**

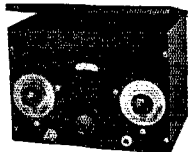

20% deposit with all C.O.D. orders. Remit by M.O. Include postage

GROSS RADIO, INC.

51 VESEY STREET

NEW YORK CITY

LEEDS LEADS

Why Not Lead with Leeds Apparatus

We have been pioneers in the ultra high frequency field, chiefly because of our engineer "56 mc Griffin's" unflagging interest in the use of the ultra-high frequencies. Over a year ago his first article on mopa transmitters appeared in *QST*, followed by another in August 1933. Our 5-A receiver is another contribution that sets a new standard for super-regenerator performance.

Now it looks as though every ham will become 56 mc minded. The July *QST* article discloses an entirely new field for amateur endeavor and enjoyment that can be justly called revolutionary.

We are prepared to fill your requirements for quality apparatus and parts at the lowest prices. Our engineering department is at your service.

NEW

A 5¼ x 19 standard panel 3 position mixer, MP-3 and a combination keyer amplifier and audio oscillator on a 5¼ x 19 panel KP-1 are now available. Ea. \$15

Amateur apparatus is "ham built" but it should have commercial "eye appeal." SO — We are pleased to introduce a complete line of LEEDS cased audio transformers that are ideal for base mounting; all leads are coded and go through one ⅜" hole in the chassis. You can save both time and money with these transformers and improve the appearance of your equipment at the same time.

Double button mike to grid; single plate to grid; single plate to push pull grids, plate to 500-200 ohm line; 500-200 w. line to 500-200 line. Any type \$1.75.

LEEDS Sensitive Relays, ideal for that keying unit operating on 1.5 MA. . . . \$3.00

We now have descriptive bulletins available on all LEEDS Amateur units. 1-B Freq-monitor, 1-C Wavemeter, 1-D Freq-meter checker, 1-E and 1-F Power supplies, 5-A Receiver, DB 5-0 56 mc Oscillator, DB-5-A 56 mc amplifier, DBS Speech Amplifier, DB 46M-210M Modulator Units, MP-3 and KP-1 units, Demi Base, Full Base, Standard Rack Panels and Racks.

Just send us 5c stamps or coin for these data sheets.

45 Vesey St., New York City

ment and education we can obtain and afford to others, and not a bunch of operators, either Morse or c.w. that are trying to "put someone under the table." I hope that I have in some remote cases cleared up any illusion that Morse operators are inclined to "blast" their way through a QSO, I've met my first one yet who tried it, but I've had a few c.w. amateurs send me stuff that sounded very much like a Kleinschmidt multiplex going its best.

—Leonard Collett, W9DEA

Crystal Control—The Key to Heaven

Hinsdale, Illinois

Editor, *QST*:

"Occasionally there springs up in the amateur ranks a pest—or better, a parasite—" or so we've been told.

It appears that this foul creature takes an unholy joy in tormenting those few of our righteous brethren who are wont to sit back in crystal-controlled complacency, knowing that their signals are the perfect picture of virginal purity and innocence.

Who is this fiend, warped and twisted as he must be, who insinuates himself into a QSO only to hurl poison darts of criticism at his victim? Why must he smear the conscious virtue of these alabaster saints? What can be his hidden purpose? Does he suffer from hallucinations that he finds evil where it does not exist? Or can it be that the evil *does* exist? Is it possible that conceit and a crystal are insufficient to guarantee perfection?

We have heard many a ". . . t4 signal . . ." that was ". . . out of the band and wobbling back and forth, besides a few other discrepancies . . ." and, upon closer inspection a T9 parent signal was discovered well within the band, signing the same call, working the same station, and otherwise indicating origin from the same source. In one of these instances, the FRC also heard and promptly QSL'd the chagrined amateur. Has the commission gone in for ". . . Rotten Humor . . .?"

We firmly believe it is our duty to report all poor quality signals to the operators; therefore, if any list of macabre humorists is to be made, we respectfully request to be included.

—W9EAY

—W9IPP/PVH

How About Television?

140 Rumsey Road, Yonkers, N. Y.

Editor, *QST*:

The phrase, "Television is just around the corner" has a familiar ring. It is said one way or another every year—the latest grammatical contortion being, "Television is here, but—".

I think it is time we amateurs gave television a thought. The thrill of being the first to reach out into new realms should scamper through the

SUMMER TIME IS VACATION TIME

Whether you travel "Cook's Tours" — "By Auto" or just walk the "ties," drop in at LEEDS when in New York. We are always happy to meet our amateur friends from other sections of the country. By the way, LEEDS is New York Headquarters for radio amateurs.

It Won't Comb Your Hair—It Won't Brush Your Teeth—BUT the Amateur's Analyzer, as described and illustrated in the June issue, performs a number of functions that are essential to proper operation of your station. In the long run it will save you money by insuring proper operation of your equipment. Complete unit wired and tested **\$17.50**. Complete kit of parts **\$11.95**.

NATIONAL

After four years rapid radio growth, the SW-3 still remains the standard of comparison for tuned r. f. receivers.

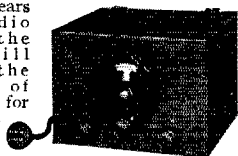

A.C. 2½v.
D.C. 6 v.
D.C. 2 v.

\$17.70

All short wave and band spread coil ranges **\$3.00**

"The Good Book" says:

(11th edition, p. 70) that every amateur station should employ an absorption wavemeter. May we suggest our type 1-C unit which covers all the amateur bands. It is a simplified version of the wavemeter feature of the Amateur's Analyzer described in the June issue. Dope sheet on request. Complete **\$4.25** kit.....

Cut your own socket and meter holes with a "PAWOOD" circle cutter. No. 2 for holes 1 to 4" diameter **\$1.25**. No. 5 heavy duty 1 to 5" diameter.....**\$1.95**
Extra blades **30c**.

Since we introduced "STRETCHLESS" antenna wire, we have found it necessary to buy it by the mile, to meet the demand of particular amateurs. *All hard drawn.*

#12 tinned copper wire, 100 ft. **55c**
#10 tinned copper wire, 100 ft. **85c**
#12 phosphor bronze wire, 100 ft. **75c**
#10 phosphor bronze wire, 100 ft. **\$1.25**
Other lengths in proportion

Our prices on Hammarlund and Cardwell products are list prices less a maximum discount of 40% and 2% for cash. Leeds policy does not include unfair competitive practices and we have no desire to engage in competition unfair to other Hammarlund and Cardwell distributors.

The Customer is NOT always Right. Quite often we find orders coming in for parts that are not only expensive but really not suitable for the job. They may be inadequate in size or excessively overrated. In such cases we point out the error and suggest more suitable parts. Competent engineering is part of LEEDS Service for those who desire it.

We are pleased to announce

3 new relay racks for standard 19" panels.
1st—table model 35" high, type RAD at..... **\$8.95**
2nd—a floor mounting unit 5' 6" high, type RBD, at..... **16.75**
You can save plenty of money by getting these units without the standard panel mounting holes, drilling those necessary for your own needs.
Table model type RAU 35" at... **\$5.45**
Floor model type KBU 66" at... **11.35**

HAVE YOU ANY DEMI-BASE UNITS IN YOUR SHACK—NO?

they give your equipment snap and neatness that cannot be equalled. Remember they can be used bread board style, in open frame, or standard 19" rack construction without changes.
8" x 8½" x 2" .55c 10" x 8½" x 2" .65c
Full size bases
4" x 17" x 2" .75c 8" x 17" x 2" **\$1.00**
10" x 17" x 2" **\$1.20**

TRIPPLETT METERS

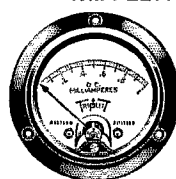

and service equipment

We carry the complete line of this high grade, low cost precision apparatus. For example 3½" bakelite case Milliameters 0-5 mils to 0-1000 in all standard ranges.....**\$3.75**

Thermo Ammeters 3½" bakelite case, 0-1 — 0-2½ — 0-5. Special....**\$6.55**

Descriptive bulletin on the complete line is yours for the asking.

The AMERICAN HAND MICROPHONE. Ideal for that 5 meter **\$3.95** transceiver. List \$10. Special....

GUARDIAN KEYING RELAY

operates on 6 to 15 volts A.C. **\$3.30** or D.C. Special.....
Guardian Break-in D.P.D.T. Relay operates on 110v. A.C.....**\$4.50**

EVERYBODY'S TALKING ABOUT our new 5-A Super Regenerative receiver, described in June *QST*. **\$13.75** brings you the most sensitive super regenerator on the market — Raring to go! **\$9.75** brings you the complete kit, including drilled cabinet and sub chassis.

LEEDS 1-B Frequency Meter Monitor

Fully described in April issue *QST*. This instrument sets a new standard in frequency monitor design. This 2-purpose instrument furnished complete with 2 tubes and large calibration chart for **\$19.75** Complete kit of parts (less tubes) **\$11.45**



NEW! We are pleased to announce that we have been appointed New York Distributors for "MYCALEX" developed by General Electric. Mycalex is not only the finest insulation, but unlike ceramic insulation, it can be sawed, drilled and tapped to suit your particular requirements.

Sheet Form	Round Rods	
Thick Per Sq. In.	Dia. Linear In.	
1/8"	1/8"	.05
3/16"	3/16"	.08
1/4"	1/4"	.12
5/16"	5/16"	.16
3/8"	3/8"	.22
1/2"	1/2"	.46
5/8"	5/8"	.75
3/4"	3/4"	.87
1"	1"	

Mycalex strips for Cardwell condensers will improve their efficiency. Undrilled strips large enough for all midway condensers **35c**. Transmitting size T-199 — T-183 etc., **55c**

In stock — The improved WING TRANSCEIVER, using the rugged 6 volt tubes. This unit is outstanding due to its durable construction, excellent receiver sensitivity and large power output, to **\$16.50** say nothing of its low price, stripped

With tubes **\$18.25**. Bronze steering column mounting **\$1.75**. We recommend the Mallory type 1 eliminator for **\$11.50** "B" supply, for automobile use.



45 Vesey Street, New York City
New York Headquarters for Transmitting Apparatus and Short Wave Equipment

OVERSEAS Export Service GOING UP!

Leeds has been working "WAC" for a long time. We are proud to announce that our 36 country record has jumped to 44 since last month.

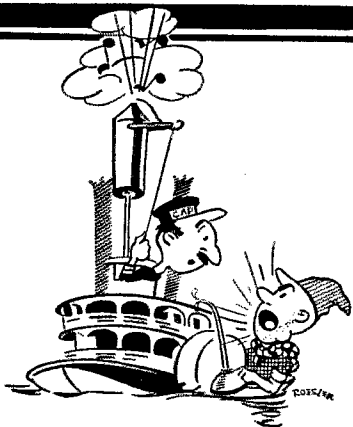

“Don't use all the steam for the whistle!”

We could easily build so gosh-dam much D.C. resistance into our suppressors that you couldn't hear a Tesla coil exploding in your gas tank. . . . but you wouldn't get any power either.

It's a case of knowing just the exact ratio of R.F. to D.C. resistance.

. . . and boy—CENTRALABS have the answer. They're sweet for noise suppression . . . and sweet for motor power.

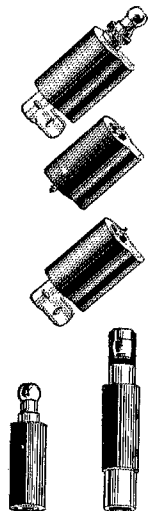

Every Radio Service Man should be a member of the Institute of Radio Service Men

Centralab MOTOR RADIO NOISE SUPPRESSORS

Central Radio Laboratories
Milwaukee, Wisconsin

veins of every radio experimenter. And it does. The excitement that followed each successive “jump” in frequency until 56 mc. was reached only started a search for new worlds to conquer. Let that search begin in the realms of television—with *QST* supplying the dope.

—Fred J. Runde, Jr.

Missouri State Convention (Midwest Division)

KANSAS CITY, MO., for the first time is sponsoring a state convention to be held at the President Hotel, August 4th–5th, under the auspices of the Heart of America Radio Club. The registration will open Saturday morning, the 4th, but, should visitors or delegates arrive early the night before, an outdoor activity meeting will be held at Swope Park. A big banquet, Saturday afternoon, at which the State Activity Cup will be presented by the S.C.M. All meetings and the banquet can be had for the registration fee of \$2.00. It's a bargain for the price; and a worthwhile prize will be up for the ham holding the lucky number if his ticket was purchased a week prior to the convention. Just write J. R. Tracy, 229 Ward Parkway, Kansas City, Mo., and register now.

Noise-Reducing Antenna Systems

(Continued from page 24)

acting as a single wire (two in parallel) capacity coupled, through the windings of the transformer, to the receiver input. The elimination of this coupling effectively eliminates the light line (which is capacitively coupled to the twisted pair by sheer proximity) as a source of noise carried off the street directly into the input of the receiver. These winding-to-winding capacities are not so important in the broadcast band, as experience has shown.

FOR HAM-BAND PEAKS

The choice of resonances in the design shown is for best performance in the prominent short-wave broadcast bands. Amateurs who have put such systems into use have been mixed in their reactions; some for, most reasonably satisfied, some indifferent. It is reasonable to argue that the amateur needs a compromise set-up in which the dimensions are about 56 feet for each top half and 31 feet for each pendant one, to give him a resultant curve of the type shown in Fig. 13 but with prominent peaks at 4 and 7 mc., and not too much drop at 14 mc.

Approximately doubling the top length of the antenna, as well as the short arms, makes an unwieldy and space-consuming rig which could not be installed in many locations. However, the antenna may be of regular dimensions with the addition of loading coils to achieve the proper electrical equivalent for the amateur bands. These loading coils are designed to increase a

FOR FREQUENCY STABILITY . . . Collins uses *Bliley Crystals*



M. B. Kahn of the Collins Radio Company inspecting a Collins Transmitter furnished Byrd Antarctic Expedition. Arrow points to Bliley Mounted Crystal which is standard equipment on the set.

To maintain their recognized standard of performance, Collins Radio Company selects equipment for its transmitters only after exacting tests.

It is a tribute to the high quality and operating performance of Bliley Mounted Crystals that they are used by this well known manufacturer of transmitting equipment.

Type BC3 mounted crystals manufactured in the 1.7, 3.5 and 7.0 Mc bands having a precision of .03% are supplied within 25 Kcs or any frequency from distributor's stock for **\$4.95**—to exact specified Kc at slight additional cost. Bliley Crystals are sold by all progressive distributors of amateur equipment. If our distributor doesn't have your choice in stock, he can get it for you quickly; order from him. Bliley Electric Company, 208 Union Station Building, Erie, Pa.



See Our Display at the 1934 World's Fair Radio Amateur Exhibit

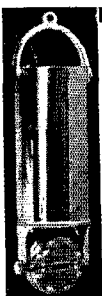

UNIVERSAL MODEL "E"

Condenser Type Microphone

Amazing quality at a sensationally low price. 90° Swivel Head with Automatic Barometric Adjustment — 2-Stage Amplifier — Non-Microphonic Tubes — Solid Bar Grating Diaphragm Protection — Polished Aluminum and Chrome Plated — At dealers' net cost of \$35.28, this is by all odds the greatest value in microphone history.

UNIVERSAL MICROPHONE CO., Ltd.
424 Warren Lane Inglewood, Calif., U. S. A.



354 GAMMATRON TRANSMITTING TUBE

Many distinctive new advantages, plus PIONEER DEPENDABILITY. Conservatively rated plate dissipation 100 watts. Write for prices and free circular.

HEINTZ AND KAUFMAN LTD.
Radio Engineers — SINCE 1919
311 California St., SAN FRANCISCO, CAL.

THE HAIGIS TRANSMITTER-RECEIVER

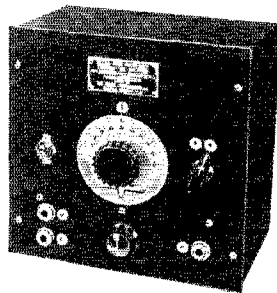

A Real
Instrument
Built by
Experts
for the
56-60 MC
Band

THE SAME
UNIT with
all its original
built-in
features.

PLUS —
Volume Control,

Filament Voltmeter Jack, Special Rheostat for 2 or 6 volt operation, and a 6 paged Instruction Book with plenty of additional Ultra-High Frequency data.

Imitations using our original circuit arrangements, minus all the features and built with little regard for electrical or mechanical design, are being offered

BUT

If you want a non-critical, very efficient unit which operates smoothly over the entire frequency range which was designed by an authority, and which is built and tested by experts, insist on The HAIGIS Type AM Transmitter-Receiver.

PRICE \$19.20 NET

The HAIGIS LABORATORIES, Inc.

Maple Shade, N. J.

Pioneers in the Ultra-High Frequency Field

For 160 and 80 Meters

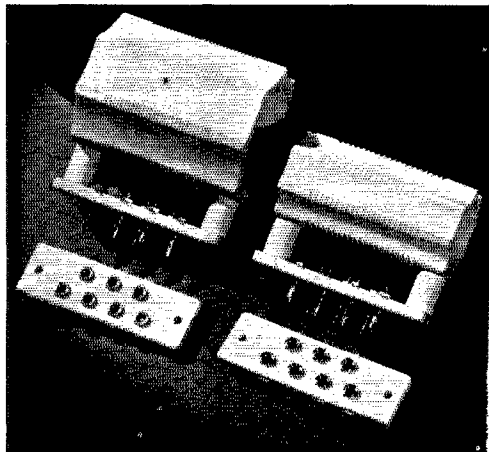

New Coil Type 677-Y, at left

As a companion to our popular Type 677-U Coil Form, a new and larger form particularly suited to 160 and 80-meter low-power transmitter use is available. Low-loss — ribbed and notched for any wire to number 12 — plug-in type or coil alone available — interchangeable with the smaller Type 677-U.

SPECIFICATIONS TYPE 677-Y COIL FORM

Over-all length.....4 $\frac{5}{8}$ inches
Winding Length.....3 inches (30 threads)
Over-all diameter.....3 $\frac{7}{8}$ inches
Inductance, wound full with No. 12 wire 69 μ h.
Fits Type 677-P Plug Base

For 160 meter Low-C and 80 meter Low or High-C circuits with provision for extra coupling turns.

PRICES

Type 677-Y Coil Form (alone).....75 cents
Type 677-PI Coil Form Spacers (2 required)
15 cents each
Type 678-P Plug Base with 7 plugs...70 cents
Coil Form Complete with Base and Spacers,
\$1.75
Type 678-J Jack Base with 7 jacks...65 cents

Order direct from this Ad. Postpaid if cash accompanies order.

Write for Bulletin 934-Q8

GENERAL RADIO COMPANY

30 State Street
CAMBRIDGE, MASS.

16 $\frac{1}{2}$ -foot length to a 29-foot equivalent. On the same basis they could increase a 29-foot length to a 41 $\frac{1}{2}$ -foot equivalent, or two of them would make the 29-foot length equivalent to 54 feet. As shown in Fig. 14, by actually increasing each 29-foot portion to 33 feet and inserting two such loading coils in series, adjacent to the center cross-over insulator, an effective 58-foot length per top half can be realized without trying to hang 116 feet of wire for both halves. Each short leg should have an inserted loading coil to raise it to 29-foot equivalence, the loading coils in every case being connected in next to the cross-over insulator. Six inexpensive and compact loading coils would be required to do this, saving about 20 additional feet of height requirement and some 50-odd feet of length. Using three loading coils per top half might permit cutting the overall span down from 66 to 41 feet, or to 20 $\frac{1}{2}$ feet per half. This also might permit some additional saving of height, although that is not especially desirable since increased height in itself helps to reduce noise pick-up.

One more point: RCA's story is that the 110-foot unit of line, which they assert must not be cut, was arrived at a few feet at a time for best overall short-wave broadcast results. One might experiment likewise for optimum length on the amateur bands. But change of the very effective transformer should not be necessary if the standard twisted line of 180-ohm impedance is used.

Operating Notes

(Continued from page 31)

Where a station controls only one other transmitter (the usual case), the intermediate operator may say: THIS IS STATION B RETRANSMITTING STATION A AND COMMUNICATING WITH STATION C. A and C will, of course, also address identifying announcements at the end of each transmission. Telegraphic relaying practice would shorten intermediate announcement to "C de B." A chain of stations A to B to C to D would sign individually as follows immediately after the announcement of the originating station (A), "B de A," "C de B," "D de C," and "A de D," the letters representing station call signals. AR, VA, K, of course, will be added, or the appropriate voice equivalents, "I am through now" (ending this transmission), "Signing off," "Goodbye," and "Go ahead," will be used by voice stations for the operating signals. This standard procedure requires only a 30-second stand-by while each individual station on the chain (on different frequencies) breaks in and identifies itself. Whether involving two or a dozen stations, the system will take the same short time for complete identification.

No reference to retransmission is necessary where the originating station has announced a "standby for identification" and the control (intermediate station) operator has properly cut off the transmission of any call signal other than his own in connection with identification periods.

GENERAL TRAFFIC PERIOD: As per the League's booklet, *Operating an Amateur Radio Station*, a daily period 6:30 to 8:00 p.m. (your local time) has been designated to help fellows not keeping schedules (or with limited operating time) who may have messages they want to get into the hands of Official Relay Station operators and other reliable men who have schedule facilities or routes. It's useful. CQ TFC is the general call made by stations that desire traffic. Stations that sign ORS should be able to help you QSP to brother hams.

NEW and DIFFERENT!

SMALL IN SIZE — BIG IN PERFORMANCE — LOW IN COST

JOHNSON TYPE "D" TRANSMITTING CONDENSERS

Single and Dual-Section (split-stator) Models

JOHNSON Type "D" Transmitting Condensers achieve capacity values and high voltage ratings in the most compact assemblies ever constructed. Though small in size, they are superior in performance to many units of larger size. Note a few of the exclusive features:

- Sturdy, rigid, polished plates, .051" thick. Heaviest plates of any condenser of comparable rating. Corners accurately rounded and polished for high flash-over voltage.
- MYCALEX Low-Loss high-frequency insulation standard.
- Integral, laminated low-resistance phosphor-bronze contacts — best ever used on small condensers.
- Bi-Metallic cone bearing front and rear. Adjustable.
- Large diameter (5/8") spacers and thick plates result in exceptional rigidity of rotor assembly.

A full range of capacity values, in both Single and Dual-Section (split-stator) types. Voltage ratings, per section: 3500 RMS. (.080" spacing) and 7000 RMS. (.175" spacing).

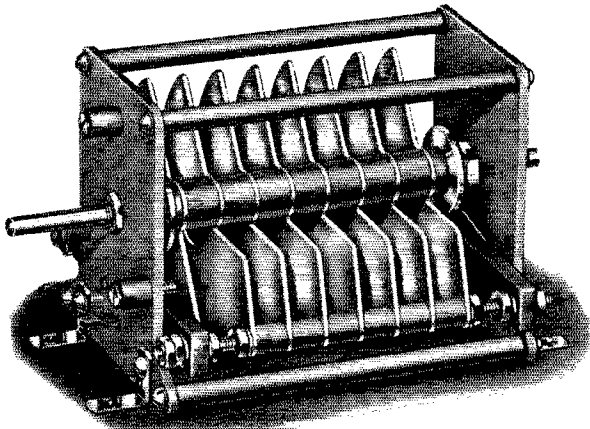

A FEW POPULAR DUAL-SECTION MODELS

No.	3500 Volt Rating Per Section Cap. Per Section	List Price
100DD35	100	\$12.50
200DD35	200	18.50

Ask Any AUTHORIZED JOHNSON DISTRIBUTOR for BULLETIN 200 Which Gives Full Details

E. F. JOHNSON COMPANY . . . WASECA, MINN., U. S. A. *Manufacturers of Radio Transmitting Equipment*



SANGAMO ACCURATE CONDENSERS

Available in 5000 volt construction for use in short wave transmitters

Write for catalog sheet

SANGAMO ELECTRIC CO.
SPRINGFIELD, ILLINOIS



*"E. H. Rietzke
SPEAKING!"*



Mr. E. H. Rietzke, President of CREI, former chief instructor at Naval Research Laboratory, and today an outstanding figure in the radio profession.

Suppose I Said . . .

"I'VE GOT A BIG JOB FOR YOU!"

. . . would you be qualified to accept it? Would your general education or radio experience give you the background required for the big jobs in Radio and the big salaries that go with them? Most men would have to say "NO", and it's for these men that we designed the CREI courses.

Enrollments now accepted for our One Year Residence Course in practical Radio Engineering beginning in September.

Every phase of Radio Engineering is covered in this thorough Residence Course. The newest equipment known to radio is in use in our laboratories, and our staff of instructors is composed of college trained men with years of actual radio engineering experience. This is not an ordinary school, but an institution offering advanced radio engineering to ambitious men. The CREI diploma is your best reference.

● WRITE FOR FREE 40-PAGE CATALOG



CAPITOL RADIO ENGINEERING INSTITUTE
14th and Park Road, Washington, D. C.
Dept. QS-8

CQ-AMATEURS of the West

Just off the Press, send for your copy

1934 CATALOG

All Nationally advertised parts
for Transmitting and Receiving
Lowest Prices

RADIO SUPPLY CO.

H. A. DEMAREST, *President*
912-14 So. Broadway Los Angeles, Calif.
(W6FBI, located in Building)

THE IMPROVED CATHODE-RAY OSCILLOSCOPE

Linear sweep model for broadcast stations and advanced amateurs, physics labs., etc.

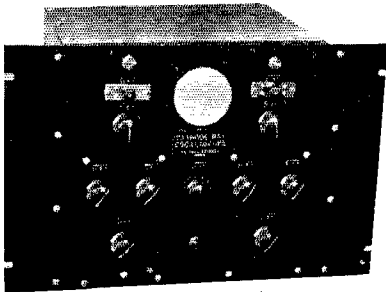

● Controlled linear sweep 0-150,000 C.P.S. ● Controlled external sweep. ● Freq. locking device for sweep frequency. ● Picture centering adjustments. ● Wide range focus adjustments. ● Complete component shielding. ● Unit is self contained and includes batteries and 110V-60 cycle power supply. ● Tubes RCA 906-885-234-281-280. ● This instrument embodies all features ordinarily contained in only the highest priced Cathode Ray equipment.

COMPLETELY EQUIPPED READY TO USE

F.O.B. Newark—\$97.50

August Dollar Sale

The prices in this sale apply only during the month ending August 31, 1934

K&R 15W-210's	1.00
Sangamo 5000V-.002	1.00
K&R 281	1.00
K&R 250	1.00
Pictal resistors R.M.A. 1 Watt —12 for	1.00
16 henry-100 ma filter chokes	1.00
C.C.A. 8 mfd-450V — Electrolytic Condenser, 2 for	1.00
3-wire shielded mike cable — 21 ft.	1.00
No. 12 Enamel wire, 200 ft.	1.00
Comb. fil. trans., 2 1/2 V-3A-7 1/2 V-3A	1.00
5" Glass insulators, 12 for	1.00
4, 5, 6, 7-prong coil forms, 8 for	1.00
58 tubes shields, 10 for	1.00
Transposition blocks, 12 for	1.00
Jacks — all types, 10 for	1.00
500 ma 5 Pi R.F. choke	1.00
K&R 866 HD	1.35

Conforming with our policy of the best apparatus for the least money, we are now able to supply a tailor-made 50-wattter with newest type construction Graphite Anode — Your choice of 211, 203-A or 845.....\$8.75

The revolutionary HAIGIS DUPLEX 5-METER TRANSCIEVER.....\$17.40

PLATE TRANSFORMER — two 7 1/2 and two 2 1/2 volt fil. windings — 750-750-160 mls.....\$3.50

DUPLEX POWER SUPPLY

1100v. 250 ma.
550v. 250ma.

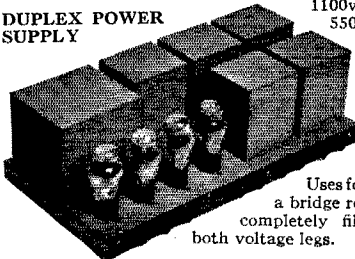

Uses four 83's in a bridge rectifier — completely filtered in both voltage legs.

\$35.00

These units can be had on special order in any size mounting or form

We are specializing in transmitter construction to customers' orders and specification. Write for quotation on your favorite transmitter.

Special code classes for beginners. No charge. Telephone for appointment.

KALTMAN & ROMANDER
62 Court St. Newark, N. J.

The time: 6:30 to 8:00 p.m. Where to look for stations to QSP? To facilitate better "general" work, it is suggested that stations get together on designated A.R.R.L. traffic channels in the following bands:

3825-3875 kcs.

3575-3625 kcs.

Some traffic moves over long jumps on 7 mc., so we wonder if it would also be helpful to suggest 7145-7155 kcs. as a "traffic frequency" in this band. That would help segregate traffic work in the center, and make the band edges better for "DX." If you like the idea, try it and tell us how it works out. Or suggest something better to improve operating for everybody, please.

OPERATORS on 14,000 kc.: Your DX will be better, less QRM on your QSOs, and more QSOs possible, if you adjust your telegraph transmitters carefully in 14,000-14,150 and 14,250-14,400 kc. sections of the band. Avoid telegraph work in the 14,150-14,250-kc. territory, where 'phone is allowed—just as you would avoid getting into 3900- to 4000- or 1800- to 2000-kc. bands. Be courteous, and check frequency as suggested, and see if you don't get more DX. Both 'phone work and c.w. on "20" will be made more enjoyable.

—F. E. H.

Standard Frequency Transmissions

Date	Schedule	Frequency	Date	Schedule	Frequency
Aug. 1	C	W9XAN	Sept. 5	BB	W9XAN
Aug. 3	B	W9XAN	Sept. 7	BB	W6XX
	A	W6XX		A	W9XAN
Aug. 8	BB	W9XAN	Sept. 8	BX	W6XX
Aug. 10	BB	W6XX	Sept. 9	C	W6XX
	A	W9XAN	Sept. 14	A	W6XX
Aug. 11	BX	W6XX	Sept. 21	B	W9XAN
Aug. 12	C	W6XX		B	W6XX
Aug. 17	A	W6XX	Sept. 26	C	W9XAN
Aug. 24	B	W9XAN	Sept. 28	B	W9XAN
	B	W6XX		A	W6XX
Aug. 29	C	W9XAN			
Aug. 31	B	W9XAN			
	A	W6XX			

STANDARD FREQUENCY SCHEDULES

Time (p.m.)	Sched. and Freq. (kc.)		Time (p.m.)	Sched. and Freq. (kc.)	
	A	B		BB	C
8:00	3500	7000	4:00	7000	14,000
8:08	3600	7100	4:08	7100	14,100
8:16	3700	7200	4:16	7200	14,200
8:24	3800	7300	4:24	7300	14,300
8:32	3900		4:32		14,400
8:40	4000				

Time (a.m.)	Sched. & Freq. (kc.)	
	BX	
6:00	7000	
6:08	7100	
6:16	7200	
6:24	7300	

The time specified in the schedules is local standard time at the transmitting station. W1XP uses Eastern Standard Time, W9XAN, Central Standard Time, and W6XX, Pacific Standard Time.

(See June QST for Procedure)

WEAR THE EMBLEM

FOR A.R.R.L. MEMBERS ONLY

USE
MEMBERSHIP
STATIONERY



Write your radio letters on League stationery. Lithographed on 8 1/4 x 11 heavy bond paper. Postpaid, 100 sheets, 50c; 250 sheets, \$1.00; 500 sheets, \$1.75.

American Radio Relay League
West Hartford, Connecticut



The League Emblem, in heavy rolled gold and black enamel, either pin or button. Special colors available for Communications Department appointees. Red background for the SCM, green background for the RM, blue background for the ORS. Red and green colors available in pin type only, blue available both in pin and button types. Price only \$1 post-paid.

PRECISION CRYSTALS

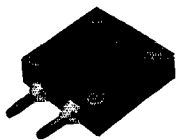

Crystal Holder

A Plug-in, dustproof holder included with each amateur band crystal purchased.

PRECISION Crystals are of the highest quality obtainable. Only after they have undergone a most rigid test and check up to the requirements of an A-1 crystal are they sent out to you with our guarantee of the finest obtainable.

PRECISION Crystals are X cut, one inch square from the finest quality of Brazilian quartz and carefully ground for maximum power output. They will be supplied to your specified frequency accurate to 0.1% and calibrated accurate to within .03%. It will pay you to buy these quality crystals. 1750 and 3500 kc. bands — \$4.50 ea. 7000 kc. band \$5.00. (Above prices include holder illustrated.) Holder alone — \$1.50. Jacks to plug holder into — .15 pair.

Crystals and ovens for commercial use quoted on at your request. When ordering our product you are assured of the finest obtainable. Now in our 5th year of business.

PRECISION PIEZO SERVICE

427 Asia Street

Baton Rouge, La.

RADIO ENGINEERING

RCA Institutes offers a combined course of high standard embracing all phases of Radio. Practical training with modern equipment at New York and Chicago schools. Also specialized courses and Home Study Courses under "No obligation" plan. Illustrated catalog on request



RCA INSTITUTES, INC. Dept. ST-34

75 Varick St., New York. 1154 Merchandise Mart, Chicago
Recognized Standard in Radio Instruction Since 1909

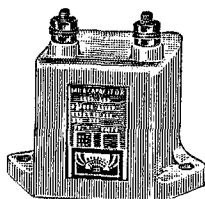

What
Every "Ham"
has been waiting for!



PORCELAIN CASED MICA UNITS

Again Cornell-Dubilier engineers sense the demand — and meet it. Here's the new Type 86 Porcelain Case Mica Capacitor for plate-grid blocking functions, featuring:

- * Far more efficient than previous types.
- * Mounted in handsome glazed black porcelain containers.
- * Minimum dielectric losses; no leakage; no metal in field;
- * Long laboratory and air tests prove them to be finest in their class.
- * No worries about breakdown.

A FEW POPULAR TYPE 86 UNITS

Cap. Mfd.	Maximum Operating V.		List Price	Your Cost
	A.C.	D.C.		
.0001.....	10,000	12,500	\$3.75	\$2.25
.00025.....	10,000	12,500	3.75	2.25
.0005.....	5,000	7,000	3.75	2.25
.001.....	10,000	12,500	5.00	3.00
.002.....	5,000	7,000	5.25	3.15
.005.....	7,500	10,000	9.50	5.70
.01.....	5,000	7,000	9.50	5.70

Write for *Dope* on this latest condenser development, as well as the complete C-D line of capacitors for every radio, laboratory and experimental requirement. See the actual units at your local supply house.

CORNELL-DUBILIER CORPORATION

JOBBERS' DIVISION

4373 Bronx Blvd.

New York City



LOOK *first* FOR THIS NAME

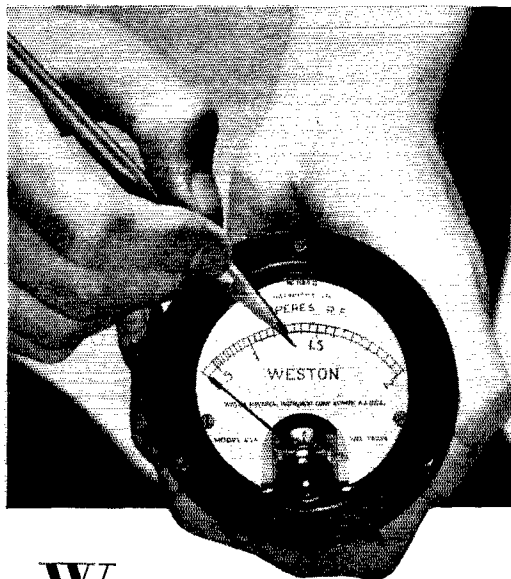

WHEN buying an instrument, look first for the name the instrument bears, for it is your best measure of design and craftsmanship. There is one name that you can accept as the symbol of quality and dependability—the name which the entire electrical industry has long accepted as the standard in instrument performance. That name is Weston. Make it your guide in selecting radio instruments... Weston Electrical Instrument Corporation, 602 Frelinghuysen Avenue, Newark, N. J.

WESTON 
Radio Instruments

WESTON ELECTRICAL INSTRUMENT CORPORATION
602 Frelinghuysen Avenue, Newark, N. J.

Send Bulletin on Weston Radio Instruments.

Name.....

Address.....

City and State.....

WWV 5000-Kc. Transmissions

The 5000-kc. transmissions of the Bureau of Standards' station, WWV, are given every Tuesday continuously from 12:00 noon to 2:00 p.m., and from 10:00 p.m. to midnight, E.S.T. These transmissions are accurate to $\frac{1}{2}$ cycle (one in ten million).

—J. J. L.

I. A. R. U. News

(Continued from page 53)

\$7, the station license fee \$13 per annum. Official receiving stations are licensed, also. The maximum power input is 50 watts. No third-party traffic is permitted.

No more hopeful omen for the future of amateur radio can be conceived than the comparative liberality of viewpoint demonstrated by this cross-section of the amateur regulations of the world, in contrast to the viewpoint exemplified by the same countries at the Washington conference in 1927. We have achieved privileges and a practical recognition undreamed of ten years ago.

—C. B. D.

New Protective Relays for Amateur Transmitters

TWO new relays of the midget magnetic type, designed for operation as protective devices in the plate circuits of transmitting tubes, are shown in the accompanying photograph. That at the left is for overload protection, the solenoid

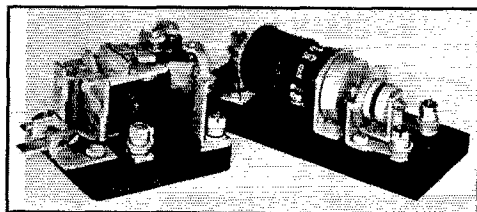

being connected in series with the negative plate supply lead. The contacts, which are normally closed, are intended to break the primary circuit of the power transformer, and are rated to carry 6 amperes at 120 volts. If a current surge occurs the contacts open and the armature is caught by a mechanical latch which must be released by hand. Two models of the relay are made, one rated to open on 250 milliamperes d.c. and the other on 500 milliamperes.

The relay at the right is for underload protection of a Class-B modulator, operating to remove the plate power from the Class-B stage should the modulated Class-C amplifier fail to draw its rated plate current. The relay coil is connected in series with the negative side of the Class-C stage plate supply; the contacts go in a similar position in the Class-B supply lead. Plate voltage cannot be applied to the modulator until

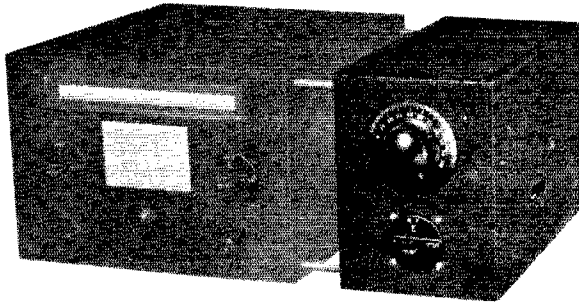

PRESELECTION

The National Preselector Unit has thoroughly demonstrated its utility for use with either superheterodyne or T.R.F. receivers. Although originally designed for use with the FB-7, it is equally effective with the SW-3 or receivers of other make. The improvement in general performance is notable with any type of receiver, while with superheterodynes the gain in image frequency suppression makes its use particularly desirable.

The preselector is designated as type PSK. Its List Price is \$25.00 including one plug-in coil. Additional coils are available to match all the FB-7 ranges, at a list price of \$6.00 per coil. A discount of 40% applies, when purchases are made through an authorized distributor.

NATIONAL COMPANY, INC., MALDEN, MASS.

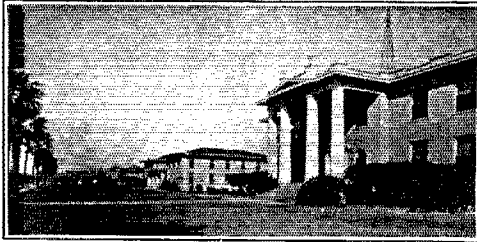

In 3 to 7 months we train you to secure government license. Course consists of Wireless Code, Radiophone, Microphone-Studio Technique, Television, Service, Police, and Aeronautical Radio. We are authorized to teach RCA Institutes, Inc., texts. Return coupon for details.

Name.....
 Street or Box.....
 City and State.....

PORT ARTHUR COLLEGE
 PORT ARTHUR, TEXAS

BIRNBACH

Highest grade, highly glazed porcelain with nickel-plated brass hardware. All standard types, including FEED-THRU models for panel mounting (plain or jack). Write for Bulletin Q-8.

BIRNBACH RADIO CO., Inc.
 145 Hudson St. New York City



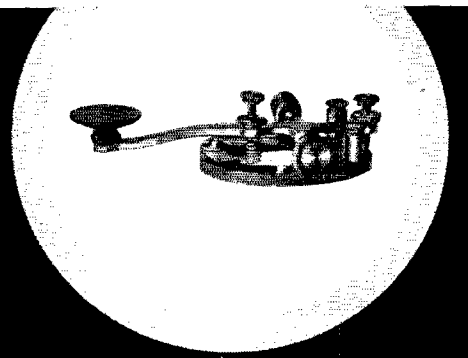

WIRELESS and TELEGRAPH INSTRUMENTS

Signal Telegraph Instruments, Wireless Keys and Wireless Practice Sets are built to scientific specifications — and are used by amateurs and commercial operators the world over. Lasting quality. Low prices. Send for circular showing complete line.

SIGNAL ELECTRIC MFG. CO.
 Menominee, Michigan

OFFICES IN PRINCIPAL CITIES

SIGNAL
 MANUFACTURERS OF ELECTRICAL PRODUCTS

★

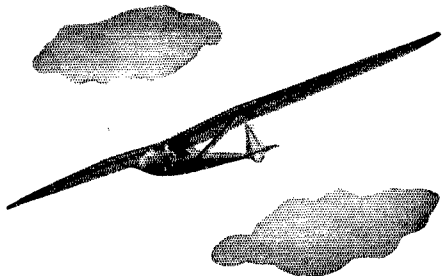

CONGRATULATIONS

ELMIRA RADIO AMATEUR

ASSOCIATION

ON YOUR CONTRIBUTION TO AMATEUR RADIO HISTORY

Through the untiring efforts of the Elmira Radio Amateur Association in co-operation with the Soaring Society of America, Inc., the first successful radiophone communication between glider pilots and from glider to ground was achieved at the National Gliding and Soaring Contests held at Elmira, N. Y., June 23 to July 8.

These communications were so successful that they were re-broadcast over the public address system at the gliding field and were clearly and distinctly heard by a large audience.

Naturally, the transceivers in the gliders were battery-powered.

Eveready Radio Batteries were used exclusively.

EVEREADY BATTERIES

★

enough current is flowing through the relay coil to provide the proper load for the modulator. The closing or "pick-up" current is adjustable by means of a screw at the top of the relay coil. Two ranges are supplied, one covering 100-200 milliamperes, the second 200-400 milliamperes. Both the overload and underload relays are adjusted for operation in the vertical position.

The new relays are made by the Ward Leonard Electric Co., Mt. Vernon, N. Y.

Northwestern Division Convention

August 18th-19th—Seattle, Wash.

HAMS! Come to the Hotel Gowman to the 1934 divisional convention to be held under the auspices of the Amateur Radio Club. Be sure to be there early Saturday morning, because a get-acquainted breakfast will be served through the courtesy of the club to all the registered delegates—your registration badge will be sufficient for your admission. The committee has prepared a good program with visits to points of interest, good speakers, entertainments to satisfy everyone. It is expected that John L. Reinartz, W1QP, who went to the Arctic Circle with MacMillan will be one of our prominent speakers. A. R. R. L. is sending Fieldman Hebert. Special rates for YL's and XYL's. Remember this: good speakers, entertainments and a real banquet. Advise C. C. Lischke, Convention Chairman, 2319 Second Avenue, Seattle, Wash., of your intention to attend.

Dr. George W. Kirk, W8ARJ

THE passing away on May 29th of Dr. George W. Kirk, W8ARJ, at the time of his death oldest licensed amateur in the United States and probably in the world, is mourned not only by relatives and close personal friends but by amateurs in this and other countries; and especially by his fellow members of the Chair Warmers Club. Dr. Kirk was 83 years of age when he died. Infantile paralysis had left him handicapped since the age of 18 months, but in spite of the fact that his left side was practically useless all his life, he carried on as few people have been able to do. He served the folk of Curtice, Ohio, for twenty-five years in the practice of medicine, retiring in 1915 when his physical disability became too great. His interest in radio dated from 1920; his first transmitter went on the air in 1930. He was a member of the Chair Warmers Club when it was first organized, being made Charter Member No. 1 in recognition of his age.

His key will henceforth be silent, but with us there will remain the spirit of a true amateur.

Introducing *The* TURNER CRYSTAL MICROPHONE

(BRUSH PATENTS)

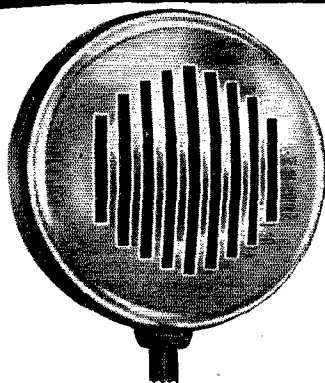

At last, the ideal microphone for amateur stations! The new Turner Type G Crystal Mike which is licensed under the Brush Patents provides a moderate-priced instrument with performance characteristics closely approaching those of high-priced condenser jobs. The Turner Type G is a precision-built crystal mike with exceptionally flat frequency response. It eliminates the hiss which is inherent to carbon mikes. Join the parade of the better amateur stations that are turning to crystal mikes as the ideal instrument for this service. The Turner Type G Mike is arranged for either spring or base mounting. List price, \$20.00. Net to amateurs, \$13.72. If your jobber is not yet supplied, send order direct. Money will be refunded if the instrument is not entirely satisfactory.

THE TURNER COMPANY, 700 Third Avenue, Cedar Rapids, Iowa

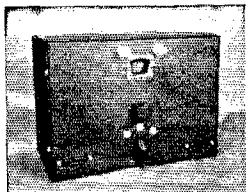

**POWER and
PORTABILITY**

Together in the
**TYPE 19 CLASS-B
MODULATED**

56 M.C. TRANSCEIVER

AS DESCRIBED IN JUNE QST BY FRANK JACOBS, W2BSL

Strong voice when Flea Power Signals fade out. Completely dry battery operated. 2 volts filament. 135 volts plate. Fil. voltage control compensates for battery deterioration. Rugged crackle finish metal case — 10 x 7 x 5 inches. Weight 9¼ pounds. Vernier dial.—Cardwell tuning condenser. Equivalent of 5 tubes — 1-30 and 2-19's.

ALL ORDERS RECEIVE THE PERSONAL ATTENTION OF
THE ORIGINAL DESIGNER

NET PRICE \$22.50—TUBES \$2.58

20% with order—balance C. O. D.

RADIO TRANSCEIVER LABORATORIES
8427-105 STREET RICHMOND HILL, N. Y.

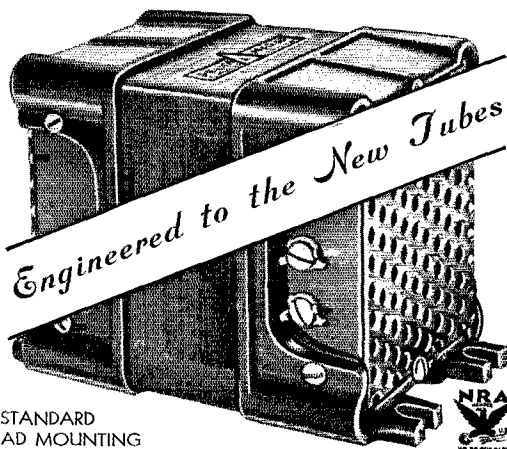

STANDARD
AD MOUNTING

ACME-DELTA POWER SUPPLY EQUIPMENT

New Acme-Delta Power and Filament Transformer and new Swinging and Smoothing Chokes, especially and specifically designed for use with the Raytheon RK-18, the remarkable new RK-20, R. C. A. 800, and the Hygrade-Sylvania 825 and 830 tubes, are now ready. See the complete catalogue in QST for December, 1933. Extra copies will be gladly sent you on request. Delta Manufacturing Co., 190 Willow St., Waltham, Mass.

F. B. Dellenbaugh, Jr.
Pres. &
Chief Engr.



G. E. M. Bertram
Treas. &
Gen. Mgr.

UNIT OF RAYTHEON MANUFACTURING COMPANY

GULF RADIO SCHOOL

Radiotelegraphy Radiotelephony
Radio Servicing

SECOND PORT 1007 Carondelet Street
U. S. A. NEW ORLEANS, LA.



Tubes for the Amateur

RK-20

50-WATT OUTPUT R. F. PENTODE

New Operating Features
Universal in Application as RF Amplifier or
Oscillator
Requires only 1.0-Watt Exciter Power or 0.2-
Watt Modulator Power

NET PRICE \$15.00

RK-18

40-WATT OUTPUT TRIODE

Efficient as Amplifier or Oscillator at High
Amateur Frequencies or as Class B Modu-
lator

40 Watts RF Output
100 Watts per pair, Class B Audio Output

NET PRICE \$10.95

RK-19

FULL WAVE LOW DROP HIGH VACUUM RECTIFIER

For 1000-Volt DC Power Supply
1250 Volts RMS per Anode
0.6 Ampere Peak Current

NET PRICE \$7.50

*Consult your nearest amateur supply dealer or write
direct to the Raytheon office near you for data on
these and other Raytheon Tubes*

RAYTHEON PRODUCTION CORPORATION

30 E. 42nd Street New York, N. Y.

or

San Francisco — Chicago — Newton, Mass.

Silent Keys

It is with deep regret that we record the passing of these amateurs:

Carl A. Arnhae, W3AJR, Summit, N. J.
John Debeve, W9GTI, North Chicago, Ill.
Earl Deets, ex-W8BGB, Youngstown, Ohio
Edward H. DeGroot III, W5AMC, Oklahoma City, Okla.
Joe Ennis, W8GPA, Johnstown, N. Y.
Benjamin Glaser, W2CFH, Cedarhurst, N. Y.
Henry B. Harris, M.I.T., Cambridge, Mass.
William Harris, Kingston, Jamaica
Dr. George W. Kirk, W8ARJ, Curtice, Ohio
John B. Little, W2FBN, New Brunswick, N. J.
Leon W. Kochevar, W9HUK, Chisholm, Minn.
Richard H. Loos, W2GOG, Linden, N. J.
George C. McClintock, W2BHR, Rahway, N. J.
Ted Ramsey, W5PY, Shreveport, La.
Clarence E. Ridgway, W6KJU, La Habra, Calif.
Eugene Sanders, W5CQB, Quapaw, Okla.

Central New York Convention

(Atlantic Division)

THE Onondaga Hotel, Syracuse, N. Y., was the scene of convention activities on Saturday, May 26, 1934. The crowd gathered early, and kept the Convention Committee busy. Visits to local broadcasting stations WFBL and WSYR were scheduled in the forenoon, and many took advantage of the opportunity.

At 1:15 p.m. a talk officially opening the convention was broadcast from WFBL by the representative from A.R.R.L. Headquarters, assisted by WSAOW. There followed general hamfesting and participation in the code speed and other contests under management of W8CP. The first afternoon meeting was a talk on League affairs by Communications Manager F. E. Handy, W1BDI, with a "question and answer" period included. A. R. Marcy, chief engineer of WFBL, discussed amplifier operation at length, showing the use of tube characteristics and formulae in computing various operating constants and arriving at conditions for practical operation. R. B. Sherman, W1BJL, discussed vacuum tubes in interesting and informative fashion.

The banquet was a fully enjoyable affair under the guidance of Toastmaster McGouldrick, W8HYR. Eleven clubs were represented, and a large group of NCR men were present. The principal banquet speaker was Dr. Burton T. Simpson, W8CPC, Assistant Director of the Atlantic

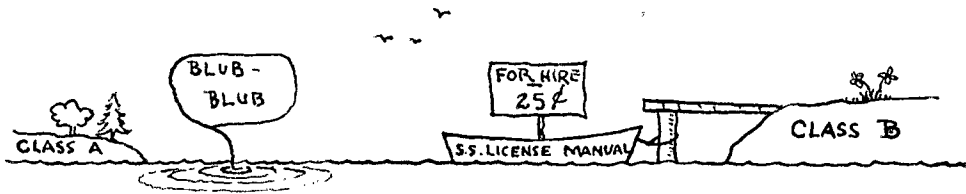

Johnny Q. Ham, one fine summer day,
 Started to swim from Class B to Class A.
 The "blub's" show his fate, so dear reader take note:
 If you try the same trip, better hire the boat!

THE RADIO AMATEUR'S LICENSE MANUAL

25c, postpaid, no stamps, please

Indispensable for the already-licensed amateur. A necessity for the beginner. Full and complete dope on renewal and modification procedure, the Class A exam (with questions and answers), portable procedure, etc. All the dope on every phase of amateur licensing procedure and, of course, the complete text of the new radio regulations and pertinent extracts from the basic radio law.

Going over your first ham ticket? You need the Manual for its instructions on where to apply, how to go about it in the right way, and most important of all, for the nearly 200 typical license exam questions and answers.

Get a copy of "The Radio Amateur's License Manual" and be sure to get your ticket.

(No. 9 in the series entitled *The Radio Amateur's Library*)

THE AMERICAN RADIO RELAY LEAGUE, WEST HARTFORD, CONN.

RADIO'S NEW DEVELOPMENT

Special Noise-Reducing Lead-In Cable

by the pioneer of noise-free aeriels

- Improves Reception
- Simple to Attach
- Inexpensive

LYNCH Cable

Makes any doublet aerial work better. Incorporates features which give low H. F. resistance; very low impedance; accurate impedance match with aerial.

See These Exceptional Results

350 feet of wire used to connect the antenna to both the receiver and the 100 watt, 1400 volt transmitter, at the New York Hamfest. Every part of the country and parts of Canada were worked on radiophone. Hams have used 165 feet to feed a 5 meter rig successfully.

Special 110 ft. length for the new R. C. A. World-wide Antenna System..... \$6.50 List

LYNCH All-Wave Antenna System \$3.50 List complete with 35 feet of the new GIANT-KILLER CABLE

Write for Free Descriptive Folder
 ARTHUR H. LYNCH, Inc., 227 Fulton St., New York, N. Y.



... Accuracy

Every Scientific Radio Service Crystal for use in the Broadcast band is ground to an accuracy of BETTER than .03% on equipment tested regularly by U. S. Bureau of Standards Standard Frequency Signals.

PIEZO ELECTRIC CRYSTALS

Scientific Radio Service was one of the "first" to introduce "Piezo Electric Crystals" for commercial use . . . that was back in 1925 . . . and today, we still pride ourselves with the fact that our aim is toward "QUALITY" Crystals rather than quantity.

"THE CRYSTAL SPECIALISTS"

Send for Booklet and Price List

Scientific
 RADIO SERVICE

124 Jackson Avenue, University Park
 Hyattsville, Maryland, Q-8

LEARN RADIO

New Classes Now Forming! Send for 40-page catalog, explains fully. 180 licensed graduates placed in past 2½ years in broadcasting, shipping, police radio, aviation, etc. We teach all branches. Oldest, largest and best equipped school in New England. Equipped with Western Electric sound and broadcasting equipment and RCA marine transmitter. Course prepares for United States Government telegraph or telephone license.

MASS. RADIO SCHOOL, 18 Boylston Street, BOSTON

To
OUR READERS
who are not
A.R.R.L. Members

YOU should become a member of the League! That you are interested in amateur radio is shown by your reading of *QST*. From it you have gained a knowledge of the nature of the League and what it does, and you have read its purposes as set forth on the page opposite the editorial page of this issue. We should like to have you become a full-fledged member and add your strength to ours in the things we are undertaking for Amateur Radio. You will have *QST* delivered at your door each month. A convenient application form is printed below — clip it out and mail it today.

A bona fide interest in amateur radio is the only essential qualification for membership



AMERICAN RADIO RELAY LEAGUE
 West Hartford, Conn., U. S. A.

I hereby apply for membership in the American Radio Relay League, and enclose \$2.50 (\$3.00 outside of the United States and its Possessions, and Canada) in payment of one year's dues, \$1.25 of which is for a subscription to *QST* for the same period. Please begin my subscription with the..... issue. Mail my Certificate of Membership and send *QST* to the following name and address.

.....

Do you know a friend who is also interested in Amateur Radio, whose name you might give us so we may send him a sample copy of *QST*?

.....

Thanks

Division. Speaking for Dr. Woodruff, who could not be present, Dr. Simpson covered the highlights of the recent Board meeting in detail. The next speaker was C. M. Handy. John Long, W8ABX (WHAM), produced his latest 56-mc. gear and, after explaining it, answered some questions on grid modulation. Ensign Wood spoke interestingly on the U.S.N.R. S.C.M. Don Farrell, W8DSP (who won the 40 w.p.m. code contest), asked hams in the W. N. Y. Section to help him build a strong Section organization by qualifying for 'phone (O.P.S.) and c.w. (O.R.S.) appointments.

The door prize was a complete transmitter like the one described on page 49 of May *QST*. This was won by a new ham holding ticket 49! After the banquet scores of additional prizes were awarded by W8QP. The holder of ticket 88 was ordered to select and kiss the prettiest YL under penalty of losing his prize. It was necessary to choose between four who tied for the honors! The convention went on record for inviting the whole Atlantic Division to Syracuse next year, and also took a rising vote of confidence in A.R.R.L.

Mr. J. L. Smith, W8AXC, received congratulations as chairman of the Convention Committee and president of the Central New York Radio Club, sponsor of the convention. Everybody had a good time due to his excellent planning, hard work of himself and club members, and coöperation from those in attendance. The banquet was concluded at a late hour. Visits to W8KIR and other local ham shacks were in order after the '04A and other prizes large and small had been awarded. The convention smashed previous ham convention attendance records in this Section, profitable meetings and renewed friendships resulted and a fine fraternal spirit prevailed. Thanks, W8AXC, and good luck, C.N.Y.R.C.

—F. E. H.

The Hudson Division Convention

THE Hudson Division Convention held on May 24th, 25th and 26th, at the Hotel Pennsylvania, in New York City, turned out to be one grand affair.

The program was full of events that appealed to amateurs of all types, modes and ages. There was a short-wave exhibit where the latest receiving and transmitting apparatus was displayed. The Garden City Radio Club and the Radio Club of Brooklyn coöperated and supplied, installed and operated three 'phone transmitters in the Official Convention Station Booth. In contrast to the modern transmitters the Nassau Radio Club installed and operated, for demonstration only, a complete old-time spark transmitting and receiving station. The noise of the "old rock crusher" proved to be of great interest to the young "squirts" in the game, and the old-timers took pleasure in telling about their experiences in the early days when radio was called wireless.

The following took part in the technical program: Hugo Romander, W2NB, lectured on and

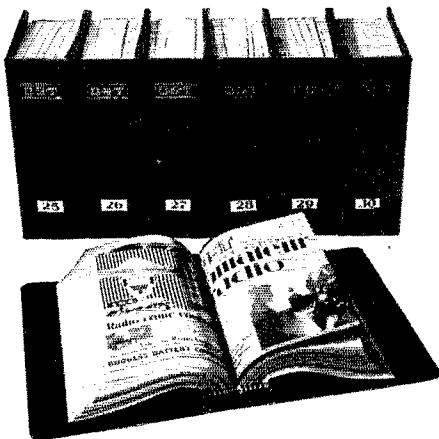

QST Binders

■ To enhance the appearance of your station, to facilitate your reference work, and to preserve the records of the advancement of the radio art, you need a BINDER. You need one for this year's issues and one for each of the accumulated year's issues that you have. It will accommodate twelve issues of QST and a yearly index. The QST Binder is covered in deep maroon cloth. It is cleverly designed to take each issue as received and hold it firmly without mutilation. It permits the removal of any desired issue without disturbing the rest of the file.

• NOTE •

The illustration shows each binder with a yearly mark. This marking is not stamped on the binder. Simply cut the year label from a calendar, or paste on a piece of paper, marking it in your own handwriting.

A GOOD INVESTMENT AT

\$1.50 POSTPAID

AMERICAN RADIO RELAY LEAGUE
West Hartford, Connecticut

READ AND SEND **CODE**

Learn Easily at Home this Quicker Way:

No experience needed. Beginners read code quickly, copy accurately. If already an op, speed up your wpm this *approved* way and make better money. "Almost human!" experts call the amazing New Master Teleplex. Only instrument ever produced which records your sending in visible dots and dashes—then *sends back* to you audibly through headphones. Fascinating, fool-proof, gets results because you learn by HEARING as well as seeing. Has taught code to more students in past few years than all other systems combined. Used by U. S. Army and Navy, R. C. A., A. T. & T., and others. We furnish Complete Course, lend you the New Master Teleplex, and give you personal instruction with a MONEY-BACK GUARANTEE. Low cost, easy terms. Write today for folder Q20; no obligation.

TELEPLEX CO.

76 Cortlandt Street
NEW YORK, N. Y.

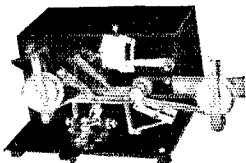

TRANSCEIVERS

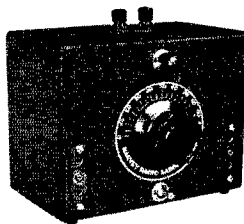

Embodying features not to be found in other similar units.

6-volt model . . . \$17.95
Tubes 1.68
2-volt model . . . 18.75
Tubes 2.04

NEW BULLETIN

Describing in detail

TRANSCEIVERS with various models and specifications.

5-10 METER TRANSMITTERS with outputs of 3-10 watts for portable or fixed use.

RK-20 POWER AMPLIFIER employing two of the new suppressor grid tubes in push-pull permitting 100 watts CW output on four bands and 30 watts when modulated. Requires but 2 watts excitation for full output.

This new bulletin is free for the asking. Write for yours today and see why, in the short space of two years, our products have been enthusiastically received in this and ten different foreign countries.

HARVEY RADIO LABORATORIES
12 Boylston Street Brookline, Mass.

LOW RANGE FUSES

- Littelfuses for Instruments: Amps.; 1/100, 1132, 1/16—20c ea. 1/8, 1/4, 3/8, 1/2—15c ea. 1, 2—10c ea. For milliammeters, ham rectifiers, etc. Use 1/8 for radio B circuits. High Voltage
- Littelfuses: 1000, 5000, 10,000 volt ranges in 1/16, 1/8, 1/4, 3/8, 1/2, 3/4, 1, 1 1/2, 2 amps. Renewable. Price 35c to \$1.25 ea.
- NOW—\$100 PROTECTION GUARANTY. Get New Cat. #5.

LITTELFUSE LABS. 4509 Ravenswood Ave., Chicago

"Quicker than a Short circuit!"

LITTELFUSES

Say You Saw It in QST — It Identifies You and Helps QST

Don't Worry About That Exam!

Candler Specialized Training Will Make It Easy for You

The better class Amateur and Com'op will tell you Candler Training in Code Fundamentals is as necessary to Skill and Speed as is a knowledge of Ohm's Law to an understanding of Electricity.

PRACTICE IS IMPORTANT. Knowing how to practice, as taught only by Candler, is more important. Any skilled op will tell you **WHAT THESE CHAMPIONS and Others Say:**

"As champion Radio op for 13 years, official speed 56 1/4 wpm., and holder of all-time American Morse speed record of 70 wpm., I can say that I never had any other training except **CANDLER SYSTEM HIGH-SPEED TELEGRAPHING and 'MILL' COURSES.**" — T. R. McElroy, 23 Bayside St., Boston, Mass.

"**CANDLER SCIENTIFIC CODE and 'MILL' COURSES** made it possible for me to win the Radio championship in Class 'E'." — Jean Hudson, W3BAK.

"**CANDLER Specialized Training** enabled me to pass rigid, competitive test for this position." — Richard D. Watson, Op., WHEW, Byrd Expedition.

"I owe my position as code instructor, Air Corps, Primary Flying School to **CANDLER Specialized Training.** I instruct over 200 student flyers in code every 4 months which requires absolute accuracy." — Carl W. Muller, 46th Squadron, Randolph Field, Texas.

"Am working trans-Pacific circuit between Honolulu and Frisco. Am combination op — American Morse and Continental. Hold a 1st class license. I could not have done this without the aid of Candler Specialized Training." — James Light, U. S. N. Radio Station WAILUPE, Honolulu, T. H.

FREE — New BOOK OF FACTS. It tells the whole story of what others are accomplishing through this unique and exclusive training. Stop worrying about your code speed and passing the exam. This **BOOK** will be a pleasant revelation to you.

CANDLER SYSTEM CO.

Dept. Q-8 6343 S. Kedzie Avenue, Chicago



demonstrated the "Cathode Ray Oscilloscope and Its Application to Amateur Stations"; E. M. Glaser, W2BRB, spoke on "Antenna Systems for Transmitters"; John L. Reinartz talked on transmitters, also presented an illustrated lecture on his experiences with the MacMillan expedition; Mr. I. A. Mitchell spoke on "Improved Circuit Data Requirements for Class B Audio Systems"; Mr. Bailey spoke on "Condensers"; Mr. J. N. Whittaker spoke on "Receivers—Then and Now"; Mr. J. K. Whittaker presented an interesting talk on "Ethics in Amateur Operation"; Mr. A. H. Lynch spoke on "Noiseless Antenna Systems"; Mr. Denton on "Modern Superhets" and Bob Hertzberg on "DX Reception."

The Open Forum presented on Saturday afternoon turned out to be one of the outstanding features of the convention. The following are a few of the prominent people present who took part in the Forum: K. B. Warner, Paul M. Segal, Dr. L. J. Dunn, Director Fuld and Dr. C. B. Jolliffe, Chief Engineer of the Federal Radio Commission.

Several inspection trips scheduled on the program were also well attended. The trips were to the new NBC Studios; the A. T. & T. Co.'s Transatlantic Radiotelephone; Broadcast Central, and the Commercial Traffic Department. Of course there were lots of contests—old and new. The liars and the code contests proved to be the most popular.

The banquet on Saturday evening wound up the convention. Among the distinguished guests were: K. B. Warner; Paul M. Segal; Dr. Charles B. Jolliffe, Lt.-Commander Freeman, Major L. J. Dunn and J. L. Reinartz. A first-class entertainment program, lasting for over one hour and under the direction of Eddie Green, W2AKM, was presented. Many outstanding entertainers took part, including the Don Hall Trio of NBC fame, a fun dancer extraordinary, a first-class orchestra and many others.

This was the second consecutive and successful convention conducted during the administration of Director B. J. Fuld. Both conventions have been under the management of S. M. Riccobono, W2TI.

—S. M. R.

Observations on Long-Delay Radio Echoes

(Continued from page 42)

I would be interested also in receiving reports of reception of long-delay echoes on any other stations, especially high-frequency stations of this country. It may, on the other hand, be difficult to be certain of any echoes observed because of the lack of silent periods as in the special signals from the two European stations.

Summaries of the results of this investigation will be made available later in publications in this country. Persons desiring to keep in touch with all details of the project meanwhile can do so by consulting the weekly issues of *World-Radio*, published by Broadcasting House, London, W. 1, England.

PROFIT BY THE EXPERIENCE OF OTHERS—Thousands of Amateurs Have Read **HINTS AND KINKS**

If you haven't yet gotten a copy of this indispensable compilation of the money-saving ideas of 189 experimenters, you'll be glad to know that the original supply, exhausted in less than six months, has been replenished by a second printing. You'll find in it hundreds of good ideas which amateurs have found helpful. It will return its cost many times in money savings — and it will save hours of time. Many of these little dodges would probably never occur to you. Order your copy at once.

HINTS AND KINKS FOR THE **RADIO AMATEUR**

No. 10 in the A.R.R.L. series entitled The Radio Amateur's Library

EIGHTY PAGES IN ATTRACTIVE PAPER COVERS

50 cents, postpaid anywhere (no stamps, please)

THE AMERICAN RADIO RELAY LEAGUE

West Hartford, Connecticut

HOW'S YOUR SUPPLY OF—

LOG BOOKS

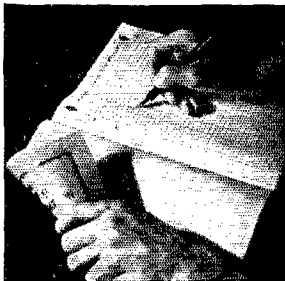

Bound with heavy paper covers. $8\frac{1}{2} \times 10\frac{3}{4}$. Contains 39 log pages, and same number of blank pages for miscellaneous notes. Also list of Q sigs, message number sheet and sheet of cross-section paper. 40c each or 3 for \$1.00. Postpaid.

MESSAGE BLANKS

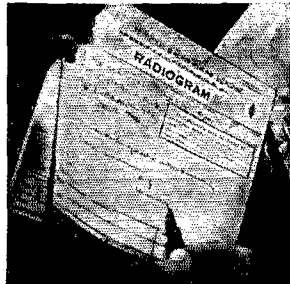

Most convenient form. Designed by the Communications Department of the A.R.R.L. Well printed on good bond paper. Size $8\frac{1}{2} \times 7\frac{1}{4}$. Put up in pads of 100 sheets. One pad postpaid for 35c or 3 pads for \$1.00.

THE AMERICAN RADIO RELAY LEAGUE—WEST HARTFORD, CONN.

APPLIED ACOUSTICS

BY

H. F. OLSON, E.E., Ph.D. and F. MASSA, B.S., MSc.
Acoustical Research Engineers, RCA-Victor Co., Inc.

444 Pages 228 Figs. Fabrikoid \$4.50

A MODERN book dealing with microphones, loud speakers, head phones and audio systems. Fully illustrated with numerous sketches and theoretical and measured characteristics of all types of modern microphones, loud speakers and head phones. Design of magnetic circuits, frequency compensation in amplifiers, oscillators, linear and logarithmic detectors, etc.

P. BLAKISTON'S SON & Co., INC.
1012 Walnut Street, Philadelphia

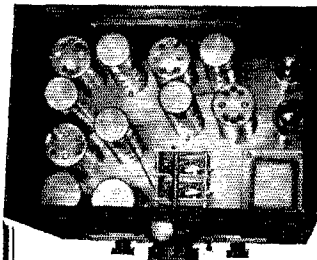

LIFT the LID!

Note the high quality of every part in the ROSS JUPITER. Study the workmanship—the design. Then try it in your own shack on amateur band reception. The results

will mean far more than any claims we might make here. Only \$69.50 with speaker (less tubes). Write for details of 5-day Test-for-Yourself offer.

A. H. ROSS & CO. Keswick Ave. & Waverly Rd.
GLENSIDE, Pa.
(Near Philadelphia)

DON'T MISS THE SPECIAL OFFER

SEE

THE

INSIDE

FRONT

COVER

THORDARSON WE STOCK 'EM ALL!

In fact we believe we have the most complete stock in the country.

Every standard transformer made by Thordarson, is in stock for rush shipment.

TRANSMITTER GUIDE

Contains exact data on all popular circuits. It is free with orders for Thordarson parts or send 10c (stamps) for postage and mailing.

Write for our free catalog

CAMERADIO
603 GRANT ST.
PITTSBURGH, PA.

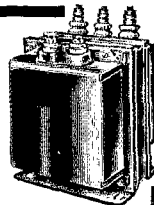

HAM-ADS

(1) Advertising shall pertain to radio and shall be of nature of interest to radio amateurs or experimenters in their pursuit of the art.

(2) No display of any character will be accepted, nor can any special typographical arrangement, such as all or part capital letters be used which would tend to make one advertisement stand out from the others.

(3) The Ham-Ad rate is 15c per word, except as noted in paragraph (4) below.

(4) Remittance in full must accompany copy. No cash or contract discount or agency commission will be allowed.

(5) Closing date for Ham-Ads is the 25th of the second month preceding publication date.

(6) A special rate of 7c per word will apply to advertising which, in our judgment, is obviously non-commercial in nature and is placed and signed by a member of the American Radio Relay League. Thus, advertising of bona fide surplus equipment owned, used and for sale by an individual or apparatus offered for exchange or advertising inquiring for special equipment, if by a member of the American Radio Relay League takes the 7c rate. An attempt to deal in apparatus in quantity for profit, even if by an individual, is commercial and takes the 15c rate. Provisions of paragraphs (1), (2), (4) and (5) apply to all advertising in this column regardless of which rate may apply.

Having made no investigation of the advertisers in the classified columns, the publishers of *QST* are unable to vouch for their integrity or for the grade or character of the products advertised.

MICROPHONE and meter repairs. Low prices. Quick service. Sound Engineering Corp., 416 N. Leavitt St., Chicago, Ill.

RADIO engineering, broadcasting, aviation and police radio, servicing, marine and Morse telegraphy taught thoroughly. All expenses low. Catalog free. Dodge's Institute, Byrd St., Valparaiso, Ind.

QUARTZ—Direct importers from Brazil of best quality pure quartz suitable for making piezo-electric crystals. Diamond Drill Carbon Co., 719 World Bldg., New York.

NEW—all is necessary tune put on air, CB-25 Gross xmtr, \$100. W. O. Porter, Kenedy, Tex.

CRYSTALS, 80, 160 bands, \$1.10. W9FHS, 4433 N. Kilbourn, Chicago.

GENERAL Electric 24/1500 volt dynamotors \$35. 24/750 volt \$25. Westinghouse 27½/350 volt with complete filter system, meter, etc., \$15. 500 cycle 500 watt 110-220 Volts \$7.50. 25/275 volt double current generators \$7.50. Henry Kienzle, 501 East 84th Street, New York.

QSLs, 75¢ a 100, two colors. W9DGH, 1816 5th Ave., N., Minneapolis, Minn.

CRYSTALS; \$1.35 Hipower oscillators 3500-1700 Kc. Bands, close to your specified frequency. 7000 Kc. \$1.25. Plug-in holders with mountings \$1.00. Blanks 65¢, immediate delivery. Send for complete price list and bulletin. Crystals for Broadcast stations, prices on request. Hipower Crystal Co., 3607 N. Luna Ave., Chicago, Ill. You cannot buy a better crystal than Hipower, at any price.

SELL—used broadcast and short wave equipment. Write for list. White Radio Lab., Sandpoint, Idaho.

GENE—Motor, 5 meter rig, transformers, parts. 1328 Crane St., Schenectady, N. Y.

QSLs! W8ED QSLs! World's finest samples! W8BED, Holland, Mich.

TRANSMITTER, \$2. W1HVK.

SEE June hamad, meters repair, satisfaction or money back. W7AJG.

WANTED; Experienced radio broadcasting engineer. Practical experience essential. Full knowledge, speech frequency circuits, microphones. Write giving experience, qualifications. Box Z, QST Hartford.

RADIOTELEPHONE engineers—original modulation system, efficient, data 30¢. Progressive Technicians, 1608.5 S. Geddes St., Syracuse, N. Y.

QSL cards, two color, cartoons, message blanks, stationery, snappy service. Write for free samples to-day. W1BEF, 16 Stockbridge Ave., Lowell, Mass.

866s, 1000 hour guarantee, \$1.49. Tubes and transmitters. Howard Radio, 314 Pine Ave., Chicago.

QSLs, SWLs, W6DOU, Hayward, Calif.

QSLs! See these first! W6FZQ, Box 1804, Phoenix, Arizona. 211Es, \$2.50; 846s, \$5. Guaranteed. W2DCJ.

WONDERFUL bargain—complete 500 watt CW transmitter. Completely metered, 3 power supplies, 204As pushpull output. Details write to W7AJV, 4016 N. E. Skidmore, Portland, Oregon, with your best offer.

WANTED, Vibroplex for cash or trade. W1GPN.

CLASS B transformers, all types, \$4.50 pair up. W9KQO, Topeka, Kans.

CRYSTALS—160-80, \$1.95. Holders. W2DBQ.

OVERLOADING transmitting tubes up to 500%—cold—safely! 500 watts from crystal oscillator! More on single sideband transmission! These and many others coming in "R/9." \$1.50 yearly; foreign, \$2.00. 1455 Glenville, Los Angeles.

NATIONAL AGS, latest model, rack mounted complete. Practically new. Wholesale cost \$281. Offer? W1KO.

CRYSTALS: 160-80 meters, approximate frequency, 1", \$1; 40 meters, \$2. Guaranteed. W8EBV, 1397 0th St., Muskegon, Mich.

SWAP, higher accountability course for short wave receiver. W9KXX.

FB7s, Teleplexes, Monographs, Vibroplexes, receivers, meters, microphones. Bought, sold, traded. Ryan Radio Co., Hannibal, Mo.

MOTOR generator, Esco 2000V, .4A, double commutator, field regulation, motor 1 hp. 110-220 single phase. Make offer. W1BES, 143 Eastwood, Providence.

NEW opportunity for amateurs, experimenters. We buy, exchange, sell or trade equipment of standard make. Write us for trade in allowance on receivers or supplies before buying. Our stock largest in middle west. National Hammarlund, Bliley, Beede, Westinghouse, etc. Walter Ashe Radio Co., 1100 Pine St., St. Louis, Mo.

QSLs, two colors. Samples. Printer, Corwith, Iowa.

SELL National SW3, 20-40-80 coils, tubes, National pack, \$18. Weston 0-15 volts a.c. \$3. Roller Smith 0-3 m.a. d.c. \$3.50. Receiver aluminum cased, 34 detector 33 audio tubes, coils, \$9. Philip Battiatto, W2ACW, 270 Fairmount Ave., Newark, N. J.

CRYSTALS: Guaranteed excellent oscillators, 160 or 80 meters, your approximate frequency \$1.35 postpaid. Crystal Maker's blanks 1" 65¢—dozen \$6.00. Irregular shapes 25¢. Improved dust-proof Bakelite holders, non-exposed 1½" silvered electrodes, plugs into G.R. or tube socket mountings, any position, 75¢—dozen \$5.40. Fisher Laboratory, 4522 Norwood, San Diego, Calif., formerly El Paso, Texas.

CLASS B transformers—Universal for two or four 46's, 210's, 800's, RK18's, etc., \$7.75 pair postpaid anywhere in United States. 70 watts of audio from 46's. Write for details. W8UD, Douglas, Michigan.

FB7-A complete. Make cash offer. W9JMO.

QSLs by Maleco. Finest in country. Free samples. Maleco. 1512 Eastern Parkway, Brooklyn, N. Y.

PEP up the station. Relay racks, panels, Hi-Q power equipment, Edison batteries, wind generators. See May display, June, July hamads. Rectifier Engineering Service.

CRYSTAL holders ruggedly designed for minimum frequency drift, \$2. Write for free information on crystals, etc. Commercial Radio Equipment Co., Box 7022, Kansas City, Mo.

GUARANTEED xtals, \$1. W9EGK.

IMMEDIATE shipment—Lowest prices: All National, Hammarlund, Patterson, RME9D, Silver receivers. Trade-in your receiver. Patterson preselector \$17.64. Taylor 866s \$1.65, 825s \$4.95, 203-Bs \$7.50, 203-As \$12.50. Any other apparatus. Teleplexes rented. Write. Henry's Radio Shop, Butler, Mo.

SELL transmitter, Hartley single 210, 500 watt power supply, tubes, antenna. All for \$15. cash. W3DDW.

CRYSTALS, guaranteed. 160-80 meter, ¾ to 1", X or Y, within 10 kc., \$1.35. 1", within 2 kc. \$2.25, oscillating blanks 75¢, blanks from the saw 50¢, grinding instructions 25¢, plug-in holders, \$1. Wm. Threm, W8FN, 4021 Davis Ave., Cheviot, Ohio.

CRYSTALS, 160-80 meter. Trade for tubes, meters, transformers. Bill Threm, W8FN, 4021 Davis Ave., Cheviot, Ohio.

TWO new Taylor 825's, \$3.50 each. W3BDS.

WANTED—204A. W8KQQ.

WILL pay cash. Best offer. 100 watt 160 fone complete. W9KQC.

CRYSTALS: 1" sq. x-cut 80-160 meters within 5-ke. your specified frequency, \$2. 7 mc. 25-ke., \$3.75. Unconditionally guaranteed. Plug-in dustproof holders, silvered electrodes, 75¢. Gentry Labs., 803 W. Maple, Independence, Mo.

PATTERSON short wave receivers, six to ten tubes, free dope, write to-day. We stock and wholesale all nationally known parts for service and hams. Quicker service. Lyon-Wyatt Radio, Wichita, Kans.

MARINE tubes—send for catalog and introductory price list on these U. S. Navy approved graphite anode tubes, all types. See our June, July Hamads for transmitter-receivers, receivers and other popular items. We now ship prepaid all transmitters, receivers, etc. L. I. Marine & Electric Co., Stuart Bldg., Jamaica, N. Y.

50 Watters, \$7.50; 203As and 854s, new. Amateur Service, Fairview, N. J.

CARBON anode 50 watt tubes, \$9.75 each. New, first quality and fully guaranteed. VTE Laboratories, Ridgefield, N. J.

TRANSCIVER, \$10.75; three tube receiver, operates a.c.-d.c. Write for information. We build to order. Precision Radio Labs., 109 E. 94 Street, Brooklyn, N. Y.

Radio Operating Radio Servicing—

Classes open for Fall term—
September 4th

Prepare for the new Government Radio Operating license examinations; Radio Operator, Marine and Broadcasting. Also Radio Amateur Telegraph and Telephone. Resident courses.

Write for Booklet

NEW YORK YMCA SCHOOLS
4 West 63rd Street, New York City



NOW . . . A FULL-SIZE 2-BUTTON MICROPHONE

AT ONLY \$10 LIST!

The new Shure Model 5B—
Ideal for amateur radio-telephone transmitters and low cost sound systems. The large frames with the regular full-size precision adjustable buttons assure superior tone quality. Performance, quality of materials and the exclusive SHURE features are retained. Diameter, 3 3/4" overall—Weight, 15 1/2 ozs.

Subject to Licensed-Amateur Discount AT YOUR JOBBER.

SHURE BROTHERS COMPANY

Microphone Headquarters

215 W. HURON ST. CHICAGO

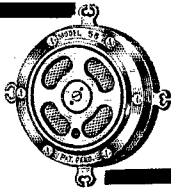

Which Way is Best for CODE Practice at Home?

Before making a decision, send post card for details of the **Instructograph Automatic Code Teacher**. Provides CODE practice at any speed. Saves time, money and disappointment. Terms as low as \$2 per month. Rent for a month. Convince yourself—in your own home that this is the best way to practice code at home. If not, send it back.

INSTRUCTOGRAPH CO., Dept. Q-8
912 Lakeside Place Chicago



PANELS—BAKELITE—RUBBER—ALUMINUM

All Sizes Cut to Order BAKELITE TUBING & RODS

Drilling, Engraving & Special Work
ALUMINUM GANS—Stock sizes. Special sizes, made to order.
ALUMINUM CHASSIS—Threaded brass studs for 6/32 screws. Length from 1/4" to 6"—price 5c to 30c.

Insulating bushings for all size shafts
Couplings in brass or bakelite—15c
Bakelite Tubing Threaded to Specifications.

UNITED RADIO MFG. CO. Est. 1923 191 Greenwich St., New York

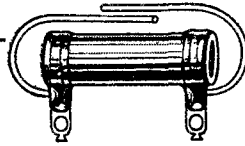

You'll Like This Husky TEN-WATTER

WIRE-WOUND, vitreous-enamelled, non-porous. Rapid heat dissipation.

Non-corrosive Monel Metal contact bands and lugs, plus pigtails for convenience.

Same type made in three sizes, three ratings and 67 resistance values.

Write Dept. Q-8 for FREE General Catalog and Vest Pocket Volume Control Guide



THE RADIO SHACK GUARANTEES
every purchase—100%—if not satisfied return it in 5 days for a refund.

CAN YOU ASK FOR MORE?

PYRANOL TRANSMITTING CONDENSERS
2MFD-2000V \$2.50

1000 already sold — get yours now

POWER TRANSFORMERS		30H-150 Mil. Choke complete cased
600-0-600 200 mils.		200 D.C. Res. \$9c
7 1/2 V. at 3 A	\$3.95	30H-200 M. Ch. \$2.50
2 1/2 V. at 3 A		866 Fil. Trans. \$1.25
		2 1/2 V.-12 Amps.

BALDWIN TYPE C PHONES \$2.50

VT 203A (50W) \$9.00	Triad 841 \$2.50
R.S. 830 (40W) 5.95	Triad 8378
RCA 860 (used) 12.00	Triad 4678
90-day guarantee	Triad 59 1.00

HAIGIS 5M. TRANSCEIVERS \$17.40

QUOTATIONS FURNISHED

Cardwell — Hammerlund — Tobe — National — Triplett, Etc.

866 Tubes Heavy Duty \$1.69

5 METER SPECIALS

Audio Trans. with mike winding \$1.20	4 Pole D.P. Toggle switch \$.84
Output Transformer 90	R.C.A. S.B. Hand Mike 1.19
Sickles 5M. Kit 1.20	

50 Watt C. W. Outfit, Rack Mounted, 59 xtal, 841 Driver, 830 Final. Complete, ready to go \$110.00

Mail Orders Filled — Include Postage

THE RADIO SHACK

46 Brattle Street

Boston, Mass.

Your Nearest Dealer

Your nearest dealer is entitled to your patronage. You can trust him. He is equipped with a knowledge and understanding of amateur radio. He is your logical and safe source of advice and counsel on what equipment

Patronize the dealer nearest you—

<p>ALLENTOWN, PENNSYLVANIA Radio Electric Service Co. 1024 Hamilton Street Complete stocks transmitting equipment</p>	<p>CHICAGO, ILLINOIS Mid-West Radio Mart 520 S. State Street All standard lines carried in stock</p>
<p>BALTIMORE, MARYLAND Radio Electric Service Co. 303 W. Baltimore Street Everything for the amateur</p>	<p>CLEVELAND, OHIO Northern Ohio Laboratories 2073 West 85 Street Wholesale Distr. for National, Hammarlund, Thordarson, Cardwell</p>
<p>BOSTON, MASSACHUSETTS Nutter & Cross, Inc. 99A Milk Street All OMs, OWs, and YLs welcome — W1HRF</p>	<p>CLEVELAND, OHIO Radio Servicemen's Supply Co. 206 Prospect Street Wholesale Distributors catering to Amateurs, Dealers, Servicemen</p>
<p>BROCKTON, MASSACHUSETTS Ware Radio Supply Company 913 Centre Street Everything in parts. Comet Pro in stock with crystal filter</p>	<p>DENVER, COLORADO Inter-State Radio & Supply Co. 1639 Tremont Place Amateur Radio Headquarters in the Rocky Mountain Region</p>
<p>BUFFALO, NEW YORK Dymac Radio 359 Capen Blvd. — Tel. Univ. 9380 Complete Stock Amateur Parts — Standard Discounts — W8AWK</p>	<p>DETROIT, MICHIGAN Radio Equipment Sales Co. 14036 Woodward Avenue, Highland Park A complete stock of amateur, shortwave and service parts</p>
<p>BUFFALO, NEW YORK Kronson Service Company 143 East Genesee Street Western New York's largest wholesale distributors — W8EHF</p>	<p>DETROIT, MICHIGAN Radio Specialties Company 171 E. Jefferson Avenue Ham Supplies — National & Hammarlund Sets and Parts</p>
<p>CHARLOTTE, MICHIGAN General Engineering Corporation Everything for the Transmitting Station</p>	<p>DETROIT, MICHIGAN Serlin 1419 Broadway Detroit's Pioneer Radio Merchants</p>
<p>CHICAGO, ILLINOIS Allied Radio Corporation 833 West Jackson Blvd. Distributors National, Hammarlund and Cardwell Lines</p>	<p>ERIE, PENNSYLVANIA Jordan Radio Laboratory 1019 East Fifth Street Amateur, service parts, including Bliley, National, Raytheon. W8CXG</p>
<p>CHICAGO, ILLINOIS Chicago Radio Apparatus Company 415 South Dearborn Street Dependable Radio Equipment. Established 1921. All Standard Lines</p>	<p>HARTFORD, CONNECTICUT Radio Inspection Service Company 227 Asylum Street Yes, we'll take your old set in trade</p>
<p>CHICAGO, ILLINOIS Newark Electric Company 226 W. Madison Street Chicago's oldest radio parts store — established 1921 John T. Wallace, Technical Adviser</p>	<p>HOUSTON, TEXAS Straus-Frank Company Distributors for nationally advertised amateur products RCA-DeForest transmitting tubes</p> <p>JACKSONVILLE, FLORIDA Glover Weiss Co. Radio Headquarters for Southeast Distributors: RCA Victor, Stromberg-Carlson, Standard Ham Lines</p> <p>KANSAS CITY, MISSOURI Burstein-Applebee Company 1012-14 McGee Street "Specialists" in supplies for the Amateur and Serviceman</p>

This advertisement is paid for by the firms listed above. Qualifies dealers

Is Your Best Friend

you should buy. His stock is complete. He can supply your needs without delay. His prices are fair and consistent with the high quality of the goods he carries. He is responsible to you and interested in you.

You can have confidence in him

<p>KANSAS CITY, MISSOURI Radio Laboratories 1515 Grand Avenue Amateur Headquarters — Complete Stock — Quality Parts</p>	<p>ST. PAUL, MINNESOTA Lew Bonn Company 2484 University Avenue Rex L. Munger, W9LIP, Sales Engineer Radio Wholesaler Complete Stock</p>
<p>MANCHESTER, NEW HAMPSHIRE Radio Service Lab. of N. H. 1008 Elm Street — Tel. 218-W Branches — Portland, Me. and Barre, Vt</p>	<p>SAN ANTONIO, TEXAS Straus-Frank Company Distributors for nationally advertised amateur products RCA-DeForest transmitting tubes</p>
<p>MILWAUKEE, WISCONSIN Radio Parts Company, Inc. 332 West State Street Complete stock Nationally Known products</p>	<p>SAN FRANCISCO, CALIFORNIA Offenbach Electric Company, Ltd. 1452 Market Street "The House of a Million Radio Parts"</p>
<p>NEWARK, NEW JERSEY Kaltman & Romander 62 Court Street Drop in for an over-counter QSO</p>	<p>SPRINGFIELD, MASSACHUSETTS T. F. Cushing 349 Worthington Street An amateur, endeavoring to sell good parts</p>
<p>PHILADELPHIA, PENNSYLVANIA Freeland Radio Supply Co. 5 N. 7th Street "If it's radio we have it"</p>	<p>SYRACUSE, NEW YORK Roy C. Stage, W8IGF Complete stock of standard Ham & BCL parts Standard Discounts. Free technical service</p>
<p>PHILADELPHIA, PENNSYLVANIA Radio Electric Service Co., Inc. N. E. Cor. Seventh & Arch Sts. All nationally advertised lines in stock</p>	<p>TORONTO, CANADA A & A Radio Service Supply 101 Queen Street, West We specialize in service! Try it!</p>
<p>PHILADELPHIA, PENNSYLVANIA Eugene G. Wile 10 S. Tenth Street Complete Stock of Quality Merchandise</p>	<p>TORONTO, CANADA Wholesale Radio Company, Limited 355 Danforth Avenue Canada's Largest Amateur Supply House</p>
<p>PITTSBURGH, PENNSYLVANIA Cameradio Company 603 Grant Street Tri-State "Ham" Headquarters Standard Apparatus Standard Discounts</p>	<p>TRENTON, NEW JERSEY American Radio Co. 5 N. Broad Street Central Jersey's leading radio parts store</p>
<p>PROVIDENCE, RHODE ISLAND W. H. Edwards & Company 32 Broadway, Room 23 Amateur Equipment — National, Hammarlund, RCA Tubes</p>	<p>WASHINGTON, D. C. George's Radio Co. 816 F Street, N.W. Washington's largest distributor of radio parts</p>
<p>ST. LOUIS, MISSOURI Walter Ashe Radio Company 1100 Pine Street W9FIS in charge of the oldest and largest parts store in St. Louis</p>	<p>ZANESVILLE, OHIO Thompson Battery & Radio Service 128 Main Street Distributor radio equipment for amateurs and servicemen</p>

are invited to apply for rates, etc., to Advertising Department, QST

Say You Saw It in QST — It Identifies You and Helps QST

You Are Protected When You Buy From QST Advertisers

“Advertising for QST is accepted only from firms who, in the publisher’s opinion, are of established integrity and whose products secure the approval of the technical staff of the American Radio Relay League.”

Quoted from QST’s advertising rate card.

Every conceivable need of a radio amateur can be supplied by the advertisers in QST. And you will know the product has the approval of the League’s technical staff.

For Your Convenience

QST’S INDEX OF ADVERTISERS IN THIS ISSUE

A.R.R.L. Application Blank.....	86
Binder.....	87
Bookshelf.....	4
Handbook.....	95
Hints and Kinks.....	88
License Manual.....	85
Special Offer.....	Cov. 2
Supplies.....	79, 89
Birnback Radio Company, Inc.....	81
Blakiston’s Son & Co., Inc.....	89
Bliley Piezo-Electric Co.....	75
Burgess Battery Co.....	2
Cameradio Company.....	89
Candler System Co.....	88
Capitol Radio Engineering Institute.....	77
Cardwell Mfg. Corp., Allen D.....	96
Central Radio Labs.....	74
Cornell-Dubilier Corp.....	79
Delta Mfg. Company.....	83
Electrad, Inc.....	91
General Radio Company.....	76
Gross Radio Company.....	70, 71
Gulf Radio School.....	83
Haigis Laboratories.....	75
Hammarlund Mfg. Company.....	1
Harvey Radio Laboratories.....	87
Heintz & Kaufman, Ltd.....	75
Hygrade Sylvania Corp.....	6, 7
Instructograph Co.....	91
Johnson Company, E. F.....	77
Kaltman and Romander.....	78
Leeds.....	72, 73
Littelfuse Laboratories.....	87
Lynch, Inc., Arthur H.....	85
Massachusetts Radio School.....	85
National Carbon Company.....	82
National Company.....	69, 81, Cov. 3
New York Y.M.C.A. Schools.....	91
Port Arthur College.....	81
Precision Piezo Service.....	79
RCA Institutes, Inc.....	79
RCA Radiotron Company, Inc.....	Cov. 4
Radio Shack.....	91
Radio Supply Co.....	77
Radio Transceiver Labs.....	83
Raytheon Production Corp.....	84
Ross & Co., A. H.....	89
Sangamo Electric Co.....	77
Scientific Radio Service.....	85
Shure Bros. Co.....	91
Signal Electric Co.....	81
Teleplex Company.....	87
Turner Company.....	83
Union Carbide & Carbon Co.....	82
United Radio Mfg. Co.....	91
Universal Microphone Co.....	75
Weston Electrical Instrument Corp.....	80

*It Is the Radio Amateur's
Number One Piece of Equip-
ment — order your copy today*

the eleventh edition

RADIO AMATEUR'S HANDBOOK

The new eleventh edition of the Radio Amateur's Handbook is a complete revision and enlargement from the previous edition. It is the standard of the world as the textbook of Amateur Radio. Its 260 pages and 224 illustrations are a complete education in the technique and practices which have been developed through the years—right up to now.

THE MOST COMPLETE
BOOK ON AMATEUR
RADIO EVER PRINTED

Price

\$1

postpaid anywhere

(in buckram binding, \$2)

THE AMERICAN RADIO RELAY LEAGUE, INC.
West Hartford, Connecticut

Toughness
ISN'T EVERYTHING—

*...you've got to be
able to take it!*

**and
brother,**

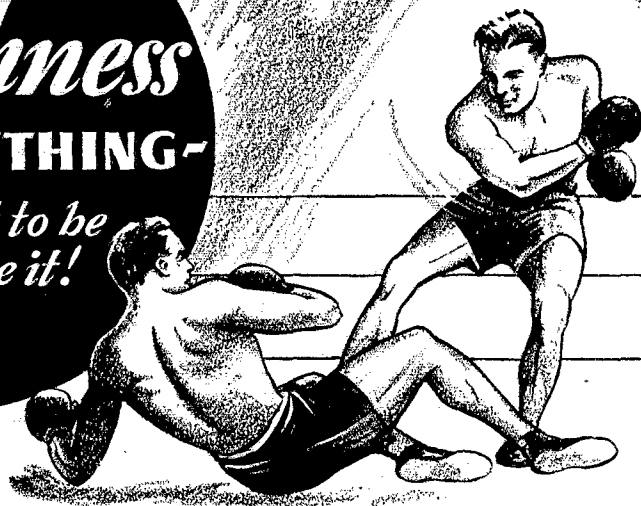

CARDWELLS can take it!

THIS IS the history of a CARDWELL condenser used and re-used for eight years by W9IOE-W9ECC. He was kind enough to give its interesting history. Here it is:

Purchased in 1925, as a Type 152-B receiving condenser—

First used in a regenerative receiver—

Triple spaced and used in monitor—

Plates replaced and used for antenna tuning condenser in 20 meter CW rig—

Double spaced and used as a neutralizing condenser with fifty watt in single-ended amplifier.

All plates replaced—now in use as tank condenser for a '10 buffer amplifier.

Naturally, not everyone has the time, the patience nor the skill to utilize a piece of apparatus to the extent described above, but *anyone* can appreciate the ruggedness and real worth in a condenser which will stand that kind of treatment and retain its usefulness and efficiency indefinitely.

*Send for literature describing
Cardwells for every tube and purpose.*

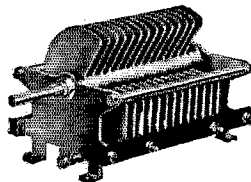

CARDWELL "STANDARD" MODELS FOR RECEIVERS
and MEDIUM POWER TRANSMITTERS

CARDWELL MIDWAY "FEATHERWEIGHT" CONDENSERS,
RECEIVING and TRANSMITTING

CARDWELL 16-B TRANSMITTING CONDENSERS
FOR LARGER TRANSMITTERS

CARDWELL HIGH VOLTAGE CONDENSERS
FOR COMMERCIAL RADIO-TELEGRAPH and
BROADCASTING STATIONS

CARDWELL S-2244 OIL DIELECTRIC FIXED CONDENSERS
FOR HIGH FREQUENCY FURNACES
and TUBE BOMBARDERS

The ALLEN D. CARDWELL MFG. CORP'N.
83 Prospect Street, Brooklyn, N. Y.

"THE STANDARD OF COMPARISON"

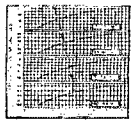
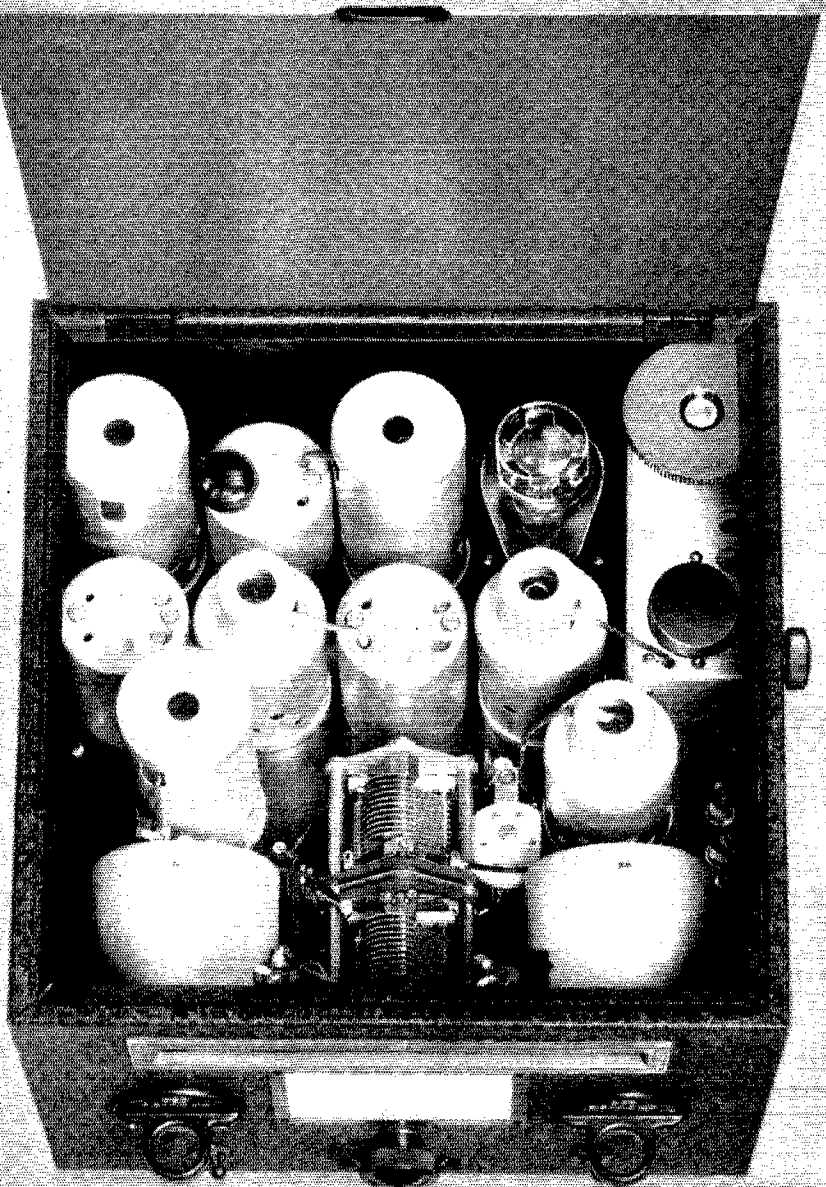

PERMANENT LOGGING

Single control, one-dial logging; Fixed Band Spread, True Tracking — these make permanent, accurate, calibration possible.



FIXED BAND SPREAD

On each of the amateur bands, the special band spread coils give a fixed uniform 100 division tuning range, no receiver adjustments being required.



PANEL COIL CHANGE

All coil changes are made through the panel of the receiver; swiftly, easily and without lifting the cover or disturbing any shieldings.



NO CROSS MODULATION

In addition to being a type of superheterodyne inherently free from cross modulation, all FB receivers employ a type 57 detector, which the most thorough laboratory tests show to be superior to any other tube for this purpose.

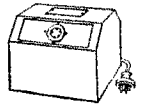

EXTERNAL POWER PACK

Saving valuable space on the operating table as well as providing an equipment flexibility that often results in tangible savings to the amateur, the external power pack is a much-prized feature of National SW receivers.

C. W. Selectivity measured in cycles rather than kilocycles and phone selectivity instantly adjustable to operation conditions, built into a receiver remarkable for sensitivity, stability and compactness. The Single-Signal FBX, National Company, Inc., Malden, Mass.

An arrangement has been made with the Canadian Marconi Company for the inclusive distribution of National receivers in Canada.

FBX

DESIGNED ESPECIALLY FOR THE AMATEUR ★ THE NEW RCA 801 ★

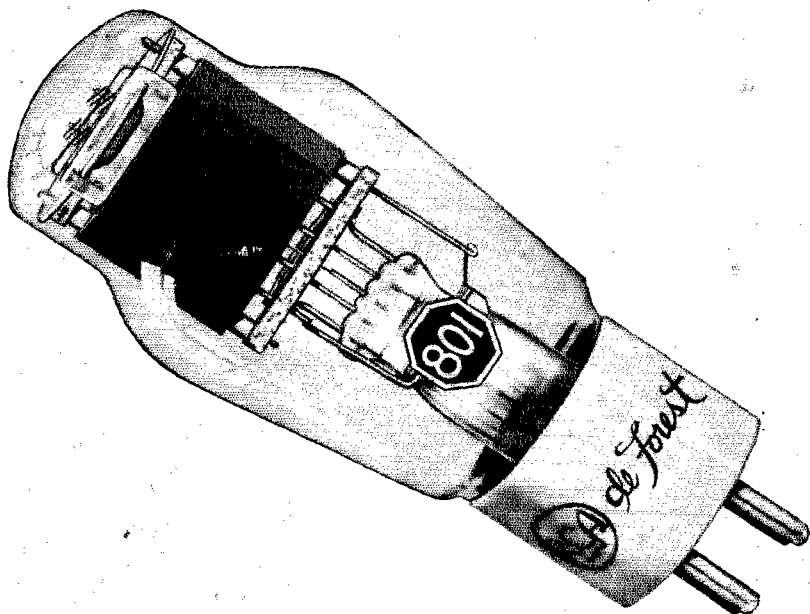

The RCA 801 is a new transmitting tube of improved design and construction. Interchangeable with the type 10 in amateur transmitters, the RCA 801 is capable of considerably greater plate dissipation and output and is rated at 600 maximum plate volts. ¶ Incorporating many advanced features of design, the RCA 801 will find ready application in and bring improved performance to amateur stations. ¶ The RCA 801 may be operated under maximum rated conditions of input at frequencies up to and including 60 megacycles. ¶ For characteristics and technical information on the RCA 801, or other RCA types, see your RCA deForest Distributor, or write to:

- ✓ DOME BULB
- ✓ RUGGED CONSTRUCTION
- ✓ SUPERIOR INSULATION
- ✓ PRECISION ALIGNED PARTS
- ✓ 20 WATTS PLATE DISSIPATION
- ✓ CARBON PLATE
- ✓ CERAMIC BASE
- ✓ PROXIMATED TUNGSTEN FILAMENT
- ✓ AMATEUR'S NET PRICE \$5.75

RCA deForest AMATEUR RADIO DIVISION
RCA RADIOTRON COMPANY, INC
CAMDEN NEW JERSEY